



# ENERGY CONSERVATION BUILDING CODE - 2023



This page has been intentionally  
left empty to commence the report  
on the right-hand side.

REGISTERED No. M - 302  
L.-7646

**The Gazette**  **of Pakistan**

EXTRAORDINARY  
PUBLISHED BY AUTHORITY

---

---

ISLAMABAD, WEDNESDAY, MARCH 20, 2024

---

---

PART II

Statutory Notifications (S. R. O.)

GOVERNMENT OF PAKISTAN  
MINISTRY OF ENERGY  
(Power Division)  
[NATIONAL ENERGY EFFICIENCY AND  
CONSERVATION AUTHORITY]

NOTIFICATION

*Islamabad, the 15th March, 2024*

**S. R. O. 416(I)/2024.**—In exercise of the powers conferred by section 21 read with the sub-section (3) of the section 4 and sub-section (u) of section 7 of the National Energy Efficiency and Conservation Act, 2016, the National Energy Efficiency and Conservation Board, in consultation with the National Energy Efficiency and Conservation Authority, is pleased to notify the Energy Conservation Building Codes (for Efficient Use of Energy), 2023:-

1. **Short title and commencement.**—(1) This code shall be called the Energy Conservation Building Code (for Efficient Use of Energy), 2023.

(2) This code shall come into force at once.

(1017)

Price : Rs. 6.00

[7379 (2024)/Ex. Gaz.]

2. **Definitions.**—Unless there is anything repugnant in the subject or context,—

- (a) “Act” means the National Energy Efficiency and Conservation Act, 2016 (XXX of 2016);
- (b) “Code” means the Code annexed to this SRO;

3. **Application.**—(1) This code shall apply to all types of new and old buildings situated throughout Pakistan.

(2) The Provincial Governments may amend the Code in accordance with their respective climatic conditions and jurisdiction, as outlined in clause (a) of sub-section (1) of section 13 of the Act.

(3) The Code shall apply to the engineering design of buildings and building clusters meeting any of the following criteria, namely:-

- (a) a total connected load of 50 kW or greater;
- (b) a contract demand of 75 kVA or greater;
- (c) a conditioned area of 200 m<sup>2</sup> or greater; or
- (d) unconditioned buildings with a covered area of 300 m<sup>2</sup> or more.

(4) The scope of the Code is applicable to provide minimum energy efficiency requirements for the design and construction of the following, namely:-

- (a) new building and systems thereof;
- (b) new portions of existing buildings and systems thereof, if the conditioned area or connected load exceeds the limit prescribed under para-3 (sub-section-3);
- (c) new systems and new equipment in existing buildings; and
- (d) increase in the electricity load beyond the limit prescribed under para-3 (sub-section-3).

4. **Punishment for contravention.**—Any person who contravenes the provisions of the Act, and the Code shall be liable to the punishment in accordance with the Act.

5. **Periodical revision.**—The Code shall continue in force unless reviewed every three years for earlier updates to ensure ongoing relevance and effectiveness.

6. **Repeal.**—The provisions of the Pakistan Engineering Council (Conduct and Practices of Consulting Engineers) Bye-laws, 1986 to the extent of matters covered under this code are hereby repealed.

[No. NEECA/MD/ECBC/SRO/10(03)-2024.]

DR. SARDAR MOHAZZAM,  
*Managing Director, NEECA.*

# FOREWORD

---

The building sector (residential, commercial, and public) of Pakistan is continuously growing for the past two decades, representing a compound annual growth rate of 12.3%. This sustained growth in the building sector, inefficient energy consumption, poor air quality and reduced family income due to inflation present a decent demand for energy efficient, net zero and green buildings both at government and public level. The ECBC-2023 offers energy efficient building designs, use of energy efficient appliances, renewable energy, retrofitting of the existing buildings, support to e-mobility and monitoring systems. The implementation of ECBC-2023 can bring a significant reduction (15-20%) in our building sector energy consumption and to achieve the net zero emission targets to mitigate the carbon footprints.

The Energy Conservation Building Code (ECBC-2023) sets out minimum requirements for energy-efficient design and energy conservation techniques for construction of buildings, as well as for the energy-efficient operation of building systems and equipment. To make it effective and implementable, NEECA and relevant stakeholders will thoroughly review the building bylaws of development authorities across the country to integrate the ECBC-2023 into the existing building bylaws as the Federal Government has already issued directions in this reference.

NEECA will develop a building rating system to promote EE&C. The necessary amendments will be made in ECBC-2023 to harmonize with the LEED building rating system. The ECBC-2023 will facilitate the NEECA Certified Energy Auditors and Energy Managers for the implementation of EE&C measures and retrofits in the buildings.

NEECA will coordinate with public and private stakeholders to identify the need for the revision of ECBC-2023 to ensure its relevance and effectiveness as per the best practices. These periodic reviews would fulfil the evolving need of the building sector of Pakistan. Further the participation of different sectors stakeholders would be ensured to make the code development process inclusive. It will provide an opportunity to all the stakeholders to provide their independent opinions and observation to make the amendments in ECBC-2023 for the conservation of energy resources.

# ACKNOWLEDGEMENTS

---

With the approval of the Energy Conservation Plan on February 1, 2023, the Honorable Prime Minister directed NEECA (National Energy Efficiency and Conservation Authority) and PEC (Pakistan Engineering Council) to revise the building code of Pakistan (Energy Provision-2011) within two months. NEECA took the lead in revising the building code of Pakistan (Energy Provision-2011).

We are indebted to both the Federal Minister and the Federal Secretary, MoST to provide administrative support for development of the ECBC-2023. The NEECA Board provided oversight and reviewed the Energy Conservation Building Code 2023 through consultations and provided input during steering committee meetings. The sincere efforts by PEC made it possible to complete the ECBC-2023 within the stipulated time span.

Dr. Sardar Mohazzam, Managing Director NEECA, Engr. Najeeb Haroon, Chairman PEC, and Dr. Nasir Mahmood Khan, Registrar of PEC, provided an effective leadership role for compiling and revising the code. The successful development of ECBC-2023 is the outcome of dedicated efforts and contributions of the Technical Committee (35 members) and an Advisory Committee (17 members). Their invaluable insights, drawn from real-time field experience during the implementation of similar codes, played a pivotal role in overseeing and validating the code's provisions.

NEECA acknowledges the technical inputs provided by Dr. Fiaz Chaudhary (Director, LUMS Energy Institute), Engr. Riaz Baig (Member of Pakistan HVACR Society), Engr. Ayaz Mahmood (Senior Engineer Electrical, NESPAK, Islamabad), Engr. Saeed ud Din (Chief Engineer Grid Muzaffarabad AJK), Engr. Khurram Durrani (Director Renewable Energy PEDO, KPK), Ar. Mishaal Rozina Merchant, (Member PCATP), Ar. Navaira Najeeb and Ar. Talha Saeed (Energy Consultant, LUMS Energy Institute).

NEECA team was led by Engr. Dr. Zeeshan Ullah, Director Residential and Building, NEECA, to revise the building code of Pakistan (Energy Provision-2011). The NEECA team, particularly Engr. Feroz Baig, Director Industry, Engr. Muhammad Zeeshan Ghias, Director Electrical, Engr. Syed Sajjad Khan, Director Transport, Mr. Sabieh Haider, Director Strategy Management, Mr. Muhammad Sajjad Hussain, Sr. Asst Director. Policy. Engr. Muhammad Muneeb Ahmad, Asst Director, Engr. Muhammad Umar, Manager Technical, Energy Conservation Fund (ECF), and Ms. Saima Shafi-Ur-Rehman have put their efforts to successfully complete the ECBC-2023.

We are thankful for the support from federal ministries especially Ministry of Housing and Works, provincial designated agencies (PEECA, SEECA, PEDO-

KPK, Energy & Water Resource Department AJK), ASHRAE, Pakistan HVACR Society, Development Authorities especially Capital Development Authority, and universities (NUST, UET Lahore & NED). The International Code Council also provided support by sharing their building energy code as a base document for NEECA and PEC to reference their valuable support for the development of ECBC-2023 is also acknowledged. The International partners (GIZ & UNDP) technically reviewed the ECBC-2023 and extended logistics support for the accomplishment of this process.



# TABLE OF CONTENTS

---

1	Introduction	1
2	Administration and Enforcement	8
3	Urbanization and Developments	12
4	Building Envelope	18
5	Passive Building Design	30
6	Retrofitting of Existing Buildings	46
7	Building Insulation	51
8	Heating, Ventilation, and Air Conditioning	65
9	Service Water Heating	84
10	Lighting	86
11	Electrical Power	101
12	Monitoring Devices	106
13	Geothermal Energy	109
14	Renewable Energy	117
15	Energy Management System	120
16	Charging Provisions for Electric Vehicle	124
17	Water Reuse Systems	127
18	Appendix A - Definitions, Abbreviations, and Acronyms	135
19	Annexures	146

# LIST OF TABLES

---

Table 4-1	External Walls and Roof	18
Table 4-2	External Glass Area (ñ40%)	19
Table 4-3	External Glass Area (>40%)	19
Table 4-4	Selection of Glazing SHGC Based on WWR	20
Table 4-5	SHGC and VLT for different WWR	20
Table 4-6	Roof Assembly U-factor ( $W/m^2 \cdot K$ ) Requirements for ECBC Compliant Building	23
Table 4-7	Air Leakage Values of Doors	23
Table 4-8	Skylight U-factor and SHGC Requirements	24
Table 4-9	Solar Reflectance Index Values of Basic Coloured Coatings	24
Table 4-10	R-Value of Common Roof Insulation	25
Table 4-11	Insulating Values of Common Building Materials	26
Table 4-12	Windows to Wall Ratio in Fenestrations	29
Table 5-1	Piping Insulation for Water System Design	32
Table 5-2	Performance Requirements for Water Heating Equipment	34
Table 5-3	Daylight Factors and Impact	40
Table 5-4	Estimated Electricity Reduction for Wall Materials	42
Table 7-1	Minimum Range of R-Values of Building Components	55
Table 7-2	Maximum Range U-Factors for Building Components	55
Table 7-3	Recommended Minimum Range of R-Value for Building Components	56
Table 7-4	Recommended Range of Maximum U-Factors for Buildings Components	57
Table 7-5	Suitable Methods for Calculating U-Factors for Assemblies of Opaque Building	58
Table 7-6	Solar Reflectance and Emittance Values for Various Roofing Materials	63
Table 8-1	Weather and Climate Data of Major Cities	66
Table 8-2	Inside Design Conditions	68
Table 8-3	Air Conditioners and Condensing Units	71
Table 8-4	Electrically Operated Unitary and Applied Heat Pumps	73
Table 8-5	Water Chilling Packages Minimum Efficiency Requirements	74
Table 8-6	Minimum Efficiency Requirements for Air Conditioners	75
Table 8-7	Warm Air Furnaces	76
Table 8-8	Gas and Oil-Fired Boilers-Minimum Efficiency Requirements	77
Table 8-9	Performance Requirements for Heat Rejection Equipment	78
Table 10-1	Simplified Building Method for Office Buildings	89
Table 10-2	Simplified Building Method for Retails Buildings	90

Table 10-3	Simplified Building Method for School Buildings	91
Table 10-4	Simplified Building Method for Building Exterior	92
Table 10-5	Exterior Building Lighting Power	94
Table 10-6	Interior LPD Building Area Method	96
Table 10-7	Lighting Power Density Allowances	97
Table 11-1	Maximum Operating Temperatures for Types of Insulation	102
Table 11-2	Voltage Drop Limits	102
Table 11-3	Reduction Factors for Harmonics Currents in Four Core and Five Core Cables	103
Table 16-1	EV Charging Requirements for New and Reconstructed Parking Structures	124
Table 16-2	Minimum Number of Accessible Electric Vehicle (EV) Charging	125

# LIST OF FIGURES

---

Figure 4-1	Selection of Glazing SHGC Based on WWR	19
Figure 4-2	Horizontal Shade ( $x \geq 0.234y$ )	22
Figure 4-3	Horizontal Louvres	22
Figure 4-4	Vertical Shading or Louvres	22
Figure 4-5	Influence of Windows and Skylights on Daylight Factor	28
Figure 5-1	Building Section Showing Cross Ventilation	36
Figure 5-2	High-rise Building Section Showing Stack Ventilation	37
Figure 5-3	Longer Axis of Building Should Face North and South as Much as Possible	38
Figure 5-4	Longer Axis of Building Should Face North and South as Much as Possible	39
Figure 5-5	Façade Design with External Shading	41
Figure 5-6	Square Building Centre Core	43
Figure 5-7	Square Building Core West	43
Figure 5-8	Strategic Landscaping Designed to Establish a Cooler Microclimate	44
Figure 5-9	Overall Passive Design Strategies	45
Figure 7-1	Conceptual Representation of U-factor	52
Figure 7-2	Temperature Swing	53
Figure 7-3	Construction of Mass Walls of Buildings	53

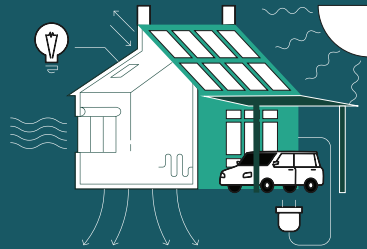

# 1

## INTRODUCTION

The Energy Conservation Building Code 2023 (ECBC-2023) in Pakistan, updating the 2011 code, aims to enhance energy efficiency in the building sector, which consumes 23% of total energy and 54% of electricity in the country. It aligns with sustainable development goals and international standards like ASHRAE and ANSI to reduce energy consumption, mitigate climate change impacts, and promote sustainability. The code, to be revised every three years, involves stakeholder input, focuses on evolving technologies and sustainable energy sources, and aims to reduce energy dependency and environmental impact.

## CHAPTER NO 1

# INTRODUCTION

---

## 1.1 BACKGROUND

Provision of reliable, affordable, accessible, and clean energy has become pre-requisite for the sustainable development. Energy conservation and efficient use of energy resources is one of the important aspects in this reference. Pakistan's building sector accounts for 23% of the total energy consumption and 54% of the total electricity produced in the country. Energy Efficiency and Conservation (EE&C) can be instrumental to tap the energy saving potential of the building sector to address the country's energy sector challenges arising due to high cost of energy and increasing demand of energy.

The Energy Conservation Building Code 2023 (ECBC-2023) has been developed through the revision of the Building Code of Pakistan (Energy Provisions-2011) to incorporate State of the art technology for implementation of EE&C measure. Further, the ECBC 2023 aims to improve energy efficiency, reduce energy consumption, mitigate climate change impacts, and enhance the overall sustainability of the built environment in the country. The ECBC-2023 aligns with key targets related to Sustainable Development Goals (SDGs), and climate change mitigation under the ambitious targets of the Paris Agreement. This adheres to relevant standards set by organizations such as ASHRAE, ANSI, ARI, ASTM, and others. The code meets international best practices and promotes energy efficiency in accordance with global benchmarks.

The code would be revised every 3 years, with the possibility of earlier updates if necessary to ensure its continued relevance and effectiveness. An inclusive revision process adopted to receive recommendations and input from stakeholders, ensuring that it remains up-to-date and reflective of evolving technologies, best practices, and energy conservation goals. The code will contribute to a more resilient and energy-efficient infrastructure, promoting economic growth while minimizing the environmental footprint of the energy sector.

The code provides an implementation and enforcement plan. Furthermore, the code recognizes the importance of sustainable energy sources in energy mix of Pakistan. The implementation of ECBC-2023 will have a significant impact on reducing the country's energy consumption and dependence on imported energy sources.

## 1.2 THE ENERGY CONSERVATION BUILDING CODE 2023 (ECBC-2023)

### 1.2.1 Purpose of ECBC-2023

The Energy Conservation Building Code 2023 (ECBC-2023) developed with the purpose of improving energy efficiency in buildings. This code provides minimum requirements for energy-efficient designs and construction of buildings and includes international best practices appropriate to Pakistan's environment. It covers a broad range of factors, including energy-efficient and low-emission construction materials, passive building design, energy appliance monitoring devices, electric vehicle charging points, energy management systems, building insulation, and renewable and geothermal energy.

Energy Conservation Building Code 2023 is an important step forward in promoting energy efficiency and sustainable building practices in Pakistan. With the promulgation of energy-efficient building design and construction, the Energy Conservation Building Code 2023 will play a pivotal role in reducing energy consumption, minimizing costs, enhancing the safety & economic health of communities, and building industry in Pakistan.

### 1.2.2 Title of ECBC-2023

The document containing the Energy Conservation Building Code 2023 (ECBC-2023) is commonly referred to as the "Energy Conservation Building Code (ECBC-2023)." This title is in the National Energy Efficiency and Conservation Act 2016 and chosen to help differentiate this document from previous versions of the building code (Energy Provisions), and to reflect its focus on promoting energy conservation and efficiency in building design and construction.

By establishing clear and concise terminology for the Energy Conservation Building Code 2023, the term "ECBC-2023" provides a useful shorthand reference for those working in the building industry, policymakers, and other stakeholders who are involved in promoting energy efficiency and sustainability in Pakistan. This will help to ensure that the code is widely understood and effectively implemented across the country".

### 1.2.3 Scope of ECBC-2023

The ECBC-2023 applies to buildings and building clusters that meet certain criteria. These include a total connected load of 50 kW or greater, a contract demand of 75 kVA or greater, a conditioned area of 200 m<sup>2</sup> or greater, or unconditioned buildings with a covered area of 300 m<sup>2</sup> or more. This code applies to the fully detached, semidetached and un-detached residential as well as commercial buildings and residential buildings to so on.

The scope of the ECBC-2023 includes several aspects of building design and construction. These include new buildings and their systems, new extension of existing buildings and their systems (provided that the conditioned area or connected load exceeds the limits mentioned above), new systems and equipment in existing buildings, and an increase in the electricity load beyond the prescribed

limits mentioned above. The code also covers the retrofitting of conventional buildings to convert them into energy-efficient buildings.

The provisions of ECBC-2023 are designed to promote energy efficiency in buildings by setting minimum standards of energy performance for new buildings, building extensions, and retrofitting projects. These standards apply to buildings that meet the specified criteria for connected load, contract demand, conditioned area, or unconditioned building area. The code includes guidelines for several systems and equipment related to energy use, including heating, cooling, ventilation, lighting, and appliances.

### **1.2.3 Applicable Building Systems Under ECBC-2023**

The Energy Conservation guidelines outlined in the ECBC-2023 cover a range of aspects related to building design and construction. These techniques are designed to promote energy efficiency and sustainability by setting minimum requirements of energy performance for key areas of building design and construction. These guidelines apply to building envelopes, which include walls, roofs, windows, and doors and establish minimum standards for insulation, air sealing, and other features that help to reduce energy loss and improve energy efficiency.

In addition to building envelopes, the ECBC-2023 also apply to building mechanical systems and equipment. This includes heating, ventilation, and air conditioning (HVAC) systems, which play a critical role in maintaining a comfortable indoor environment while minimizing energy consumption. The ECBC-2023 establishes minimum standards for HVAC systems, including equipment efficiency, ductwork design, and other factors leading to the energy efficiency.

The ECBC-2023 covers service water heating, which is a significant source of energy consumption in many buildings. This code establishes minimum standards for water heaters, including equipment efficiency and insulation requirements. Lighting is another area covered by the ECBC-2023. This code establishes minimum requirements for lighting design, including the use of energy-efficient fixtures, lighting controls, and other strategies to reduce energy consumption. Finally, the ECBC-2023 applies to electrical power and motors, which are used to operate various systems and equipment within buildings. This code establishes minimum standards for the efficiency of motors and other electrical equipment, helping to reduce energy consumption and promote sustainability.

### **1.2.4 Exemptions of Buildings from ECBC-2023**

The Energy Conservation Guidelines and Techniques outlined in the ECBC-2023 include several exemptions designed to ensure that the provisions are applied appropriately and effectively. One exemption pertains to buildings that do not use either electricity or fossil fuel as sources of energy. Such buildings may use alternative sources of energy such as solar, wind, or hydro power. Another exemption applies to government-notified historically significant and heritage buildings. Such buildings are often subject to specific regulations and guidelines related to preservation and restoration. These buildings are exempted from the



Energy Conservation Building Code 2023 to ensure that they are not subject to additional regulatory burdens that could impede their preservation. A third exemption pertains to equipment and portions of building systems that use energy exclusively for manufacturing processes. In these cases, energy consumption is necessary for production and cannot be easily reduced without compromising the manufacturing process. Therefore, such equipment and portions of building systems are exempted from the Energy Conservation Building Code 2023.

Overall, these exemptions are important in ensuring that the ECBC-2023 are applied appropriately and effectively. By excluding buildings and systems that do not consume significant amounts of energy, the ECBC-2023 can be applied more efficiently to those buildings and systems that are significant sources of energy consumption. This will promote energy efficiency and sustainability in the building industry in Pakistan, while minimizing unnecessary regulatory burdens. To reduce the burden on stakeholders, the adoption of the chapters on geothermal and renewable energy in this code is voluntary. These chapters provide clear guidelines to stakeholders on how to reduce the energy demand of buildings through the use of natural energy sources. However, these techniques require high upfront costs to implement.

### **1.3 DEVELOPMENT PROCESS OF ECBC-2023**

NEECA serves as the federal focal authority for initiating, catalyzing, and coordinating the implementation of all energy efficiency and conservation programs in all sectors of the economy. Pursuant to Section 10(p) and (q) of the NEEC Act 2016, NEECA has the power to prescribe and amend energy conservation building codes. The Building Code of Pakistan (Energy Provisions-2011), developed and notified by the Pakistan Engineering Council (PEC), requires revision/update due to changes in allied international standards, technological advancements in building energy consuming appliances, control systems, insulation technologies, green building concepts, and renewable energy technologies for buildings.

To address this need, NEECA in collaboration with PEC with the support of Ministry of Science & Technology constituted a Task Force (Technical Committee of experts across the country) to revise the Building Code of Pakistan (Energy Provisions-2011). The implementation and enforcement of this Code is the responsibility of the Federal Government directed NEECA to revise the Building Code of Pakistan (Energy Provisions-2011) within three months. NEECA collaborated with the Task Forces to revise the Building Code of Pakistan (Energy Provisions-2011) within short period of time. Therefore, this Energy Conservation Building Code-2023 will require periodic updates to improve its quality under a continual revision process.

The revised Energy Conservation Building Code focuses on high-end domestic and commercial consumers and aims to conserve energy without compromising public safety. Every effort has been made to ensure that this new Energy Conservation Building Code does not unnecessarily increase costs or

restrict the use of new materials and technology. Future development of new Energy Conservation Building Code 2023 will encompass low-end users and buildings up to 50kVA load demand and/or appropriate covered area if deemed necessary.

#### **1.4 ADOPTION OF ECBC-2023**

The revised Energy Conservation Building Code 2023 will be a fundamental element of the Building Code of Pakistan (Energy Provisions-2011). Adherence to the revised Energy Conservation Building Code will be mandatory for all new building construction, renovations, and old construction through recommended retrofitting techniques in Pakistan.

To ensure the successful implementation and enforcement of the revised ECBC-2023, the Government of Pakistan will issue a Statutory Regulatory Order (SRO) to provide comprehensive legal coverage for the Code. The notification will outline the legal procedures necessary to ensure that the new energy conservation building code is followed in all relevant building construction. The SRO will also require stakeholders to submit an energy and simulated model of the building, along with the approval drawings, during the approval stage of the buildings. This model and simulation results will demonstrate the reduction in energy demand of the building and showcase the adoption of the new Energy Conservation Building Code features during the design phase.

The concerned authority will then analyze the model and simulation results to determine whether the building design is energy efficient or not. It will enable NEECA and relevant stakeholders to make necessary changes to the code every three years to ensure that the code remains up-to-date and continues to reflect the latest advancements in energy efficiency practices. This periodic review process will ensure that the energy conservation building code remain relevant and effective in achieving the objective of reducing energy consumption and costs while enhancing the safety and economic health of communities in Pakistan.

#### **1.5 MAINTENANCE OF ECBC-2023**

To maintain the relevance and effectiveness of the ECBC-2023, the technical team at NEECA in coordination with government as well as private stakeholders will identify the need of the revision of the ECBC-2023 as per the updated tools and techniques practiced in the world. These stakeholders will be tasked with the responsibility of reviewing the code periodically and recommending necessary changes to ensure that it continues to meet the evolving needs of the building industry in Pakistan.

To ensure that the proposed changes to the code are widely accepted and relevant to the industry, representatives from different sectors of the industry, engineering professionals, and other relevant stakeholders would be engaged. This engagement would ensure an inclusive code development, which will provide stakeholders with the opportunity to express their views and opinions on the proposed changes.

The inclusive code development process would enable NEECA to collect the perspectives and concerns of all stakeholders, and to make informed decisions based on a thorough understanding of the industry's needs and challenges. It would be ensured that the proposed changes are practical, cost-effective, and in line with the latest technological advancements in energy efficiency practices. By implementing an inclusive code development process, it would be ensured that ECBC-2023 remains relevant, effective, and responsive to the needs of the building industry in Pakistan.

## **1.6 WAIVER FROM ECBC-2023**

The development of the ECBC-2023 has involved a range of individuals and organizations, who have worked diligently to ensure that the code meets the necessary standards for promoting energy efficiency in buildings. However, despite their best efforts, these individuals and organizations do not accept liability for any consequences resulting from the compliance or non-compliance of the energy provisions by practitioners.

It is important to note that the responsibility for ensuring compliance with the ECBC-2023 lies solely with the Government of Pakistan. The Government has the power and the authority to enforce the ECBC-2023 and to ensure that they are followed by practitioners. This means that the Government is accountable for any actions or decisions related to the implementation and enforcement of the ECBC-2023.

The disclaimer serves as a reminder that the individuals and organizations involved in developing the Energy Conservation Building Code 2023 cannot be held responsible for any consequences resulting from the implementation or enforcement of the Code. Instead, it is the Government of Pakistan that bears the responsibility for ensuring that the Energy Conservation Building Code 2023 are followed in order to promote energy efficiency and conservation in the building industry.

## **1.7 SOURCE DOCUMENTS FOR DEVELOPMENT OF ECBC-2023**

The revision of the Building Code of Pakistan (Energy Provisions-2011) involved the use of certain portions of ASHRAE Standard 90.1-2019, and Energy Conservation Code developed by the International Code Council (ICC). The American Society of Heating, Refrigeration and Airconditioning Engineers (ASHRAE) and International Code Council (ICC) under the authority of the Government of Pakistan, granted permission to NEECA to transcribe and reproduce portions of their document for the purpose of revising the Energy Provisions-2011.

In accordance with these agreements, NEECA and the Government of Pakistan recognize that ASHRAE and ICC retain ownership and copyright of all transcribed and reproduced portions of their document used in the revision of the Building Code of Pakistan Energy Provisions-2011. It is essential to acknowledge the contributions of ASHRAE and ICC to respect their intellectual property rights. It

is important to note that Section-2 Building Envelope, a critical component of the Energy Provisions, was developed with due consideration of the Energy Codes of regional countries and the local environment. Therefore, it does not incorporate any transcribed or reproduced portions from ASHRAE Standard 90.1-2019.

The use of ASHRAE Standard 90.1-2019 in the development of the Energy Conservation Building Code 2023 is a testament to the collaboration and cooperation between different stakeholders and organizations involved in the promotion of energy efficiency in building design and construction. The recognition of ASHRAE's contributions and their intellectual property rights reinforces the importance of respecting and acknowledging the efforts of all parties involved in the development of the Energy Provisions.

## **1.8 PROCESS FOR REVISION OF ENERGY PROVISIONS-2011**

The Building Code of Pakistan (Energy Provisions-2011), developed and notified by the Pakistan Engineering Council (PEC), required revision and updating due to changes in allied international standards, technological advancements in building energy-consuming appliances, control systems, insulation technologies, green building concepts, and renewable energy technologies for buildings. A follow-up meeting at Prime Minister Office on “Strategic Roadmap/follow-up meeting on Energy Efficiency and Conservation Measures” was held on 1<sup>st</sup> February 2023 where the chair directed NEECA to revise the energy provisions-2011. The Government of Pakistan has also tasked the National Energy Efficiency & Conservation Authority (NEECA) with the responsibility of acting as the national coordinator for energy conservation measures and policy.

Accordingly, the Managing Director - NEECA nominated Engr. Zeeshan Ullah, Director Building NEECA, as the team lead for this task. In the initial step, a technical committee of experts from all line government departments across the country was constituted on 25<sup>th</sup> January 2023 for the revision of energy provisions-2011. The first meeting of the technical committee was held on 27<sup>th</sup> January 2023 in which the need for revision of the energy provisions-2011 was discussed. The second meeting of the technical committee was held on 16<sup>th</sup> February 2023 in which an outline was finalized and chapters were distributed to the committee members. The third and the last meeting of the technical committee was held on 17<sup>th</sup> March 2023 in which the zero draft of the Energy Conservation Building Code 2023 was reviewed and discussed.

To involve developers and builders in the formation of this code, an advisory committee consisting of developers, builders, architects, designers, and practitioners was constituted on 24<sup>th</sup> February 2023. The scope of work of this committee is to provide real-time field issues in implementing energy-efficient techniques in the development of residential and commercial buildings. The first meeting of the advisory committee was held on 2<sup>nd</sup> March 2023 where the need assessment and key areas of the ECBC were discussed. The zero draft of the code was then shared with the members of the advisory committee for review and comments. The second meeting of the advisory committee was held on 13<sup>th</sup>

March 2023 in which the zero draft of the Energy Conservation Building Code was discussed in detail and the comments of the advisory committee were incorporated.

To obtain updated literature support for the ECBC-2023, the zero draft was also shared with experts from academia (JET Lahore, NED University Karachi, NUST University Islamabad), and their valuable comments and reviews were incorporated into the code. The code was then presented before the Technical Committee of NEECA Board on 21<sup>st</sup> March 2023 for endorsement and presented to NEECA Board on 24<sup>th</sup> March 2023 for approval. The schematic diagram of the whole process adopted for the development of ECBC-2023 is displayed in Figure 1-1.

### **1.9 LIMITATIONS OF ECBC-2023**

The Energy Conservation Building Code 2023 outlined in the ECBC-2023 are designed to promote energy efficiency and sustainability in the building industry in Pakistan. However, it is important to ensure that this code does not conflict with other important codes related to safety, health, or the environment.

In the event of any conflict between the ECBC-2023 and any relevant provisions of safety, health, or environmental codes, the latter shall take precedence and that in such cases the developer/designer must notify NEECA in written of such conflict so that special cases may be covered in next revision of the ECBC. This ensures that the safety and well-being of individuals, as well as the protection of the environment, remain the top priority. For example, if there is a conflict between the Energy Conservation Building Code 2023 and a provision of a safety code that relates to fire safety, the safety code provision would take precedence. Similarly, if there is a conflict between the ECBC-2023 and a provision of an environmental code that relates to the disposal of hazardous materials, the environmental code provision would take precedence.

By establishing this principle, the ECBC-2023 helps to ensure that energy efficiency and sustainability goals are pursued in a manner that is consistent with other important goals related to safety, health, and the environment.

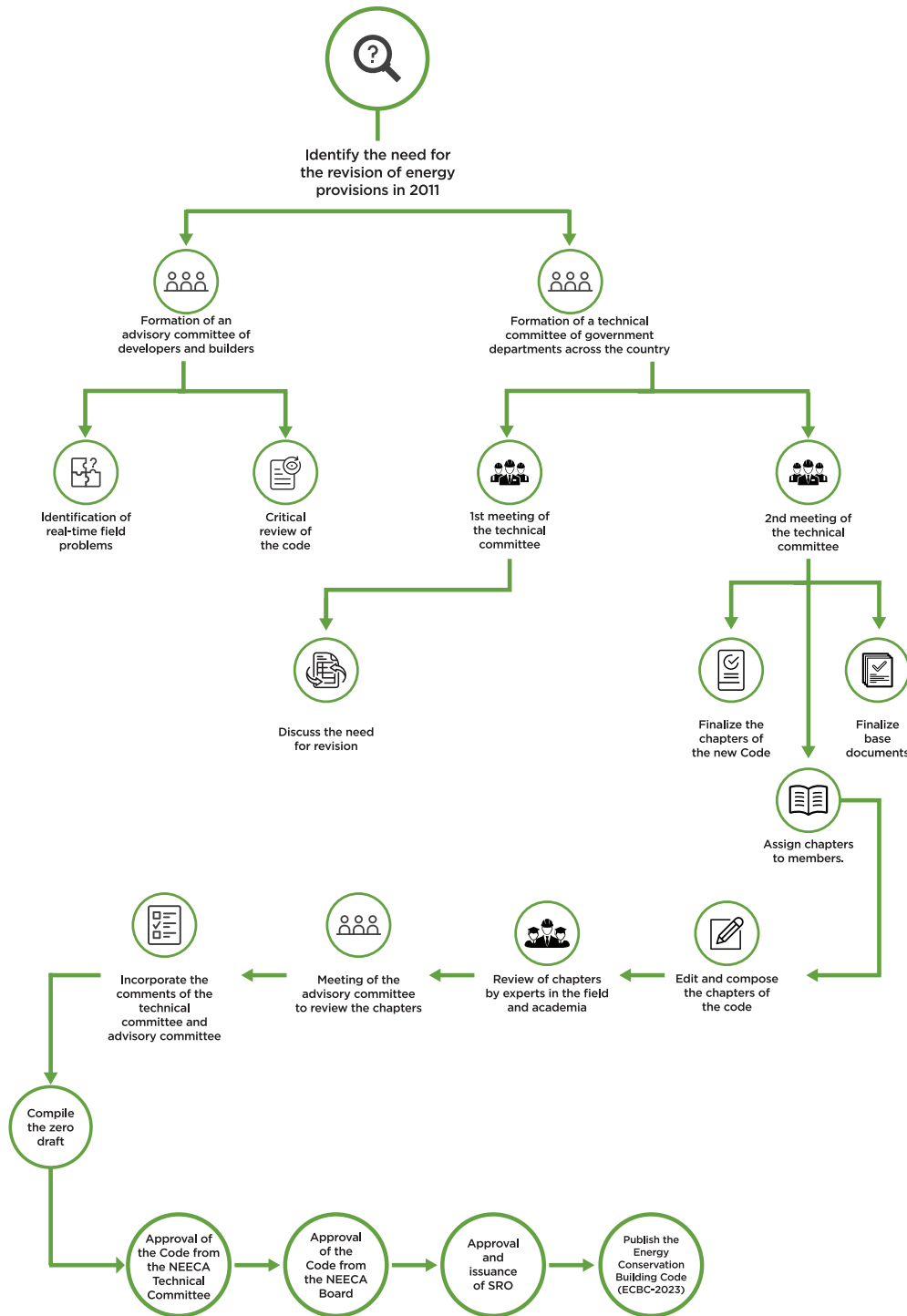
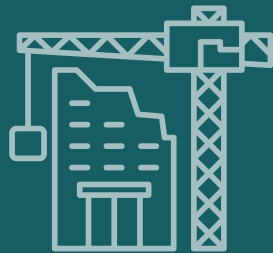

Figure 1-1: Process Flow Chart for Revision of Energy Provisions-2011



# 2

## ADMINISTRATION AND ENFORCEMENT

The Administration and Enforcement chapter of the Energy Conservation Building Code 2023 (ECBC-2023) in Pakistan sets up an administrative framework and defines responsibilities for various stakeholders, such as government authorities and building professionals, to ensure compliance with energy efficiency standards. This chapter emphasizes coordination, training, and capacity building for effective code enforcement. Additionally, NEECA will issue a Statutory Regulatory Order for legal backing, mandating simulation models and drawings for new constructions and retrofits, to demonstrate energy efficiency improvements at the design stage.

## CHAPTER NO 2

# ADMINISTRATION AND ENFORCEMENT

---

## 2.1 INTRODUCTION

The Administration and Enforcement chapter of the Energy Conservation Building Code 2023 (ECBC-2023) provides guidelines for the effective implementation and enforcement of the code. This chapter establishes the administrative framework, responsibilities, and procedures for ensuring compliance with energy conservation requirements. It outlines the roles of various stakeholders, including government authorities, building owners, designers, contractors, and inspectors, in enforcing and monitoring energy efficiency standards. The chapter emphasizes the importance of coordination, training, and capacity building to ensure effective administration and enforcement of the code. It sets the stage for a streamlined and robust process that promotes energy efficiency practices and contributes to the sustainable development of the built environment in Pakistan.

NEECA will issue a Statutory Regulatory Order (SRO) to provide comprehensive legal coverage for the implementation and enforcement of the ECBC-2023. The notification would lay down the procedure necessary for the adoption of the ECBC-2023 in all the new constructions and retrofitting of the existing buildings. It would be mandatory to submit a simulation model of the building and drawings prior to construction of the building to the concerned development authority as per the guidelines issued by NEECA. This practice would help to identify the reduction in energy demand and showcase the adoption of ECBC-2023 features at the design stage.

## 2.2 ADMINISTRATION OF THE ECBC-2023

As per the provisions of the NEECA Act 2016, the provinces can also amend/improve/develop ECBC as per their local climatic conditions, but the ECBC 2023 will serve as an umbrella document for the purpose.

- Overall administration of the ECBC will be the responsibility of NEECA and Provincial Designated Agencies (PDAs) in collaboration with PEC to revise, amend, and improve.
- NEECA & PDAs would make necessary arrangements and laid down procedures to ensure that energy efficiency and sustainability goals are pursued effectively



and consistently across the building industry in Pakistan through ECBC-2023.

- Provincial Building Control Departments, Development Authorities and Local Government Institutions may recommend amendments or revision in ECBC-2023 for the purpose of energy efficiency and conservation through PDAs or directly to NEECA in case of CDA.

### 2.3 IMPLEMENTATION REQUIREMENTS

The Energy Conservation Building Code (ECBC-2023) includes implementation requirements that pertain to several aspects of building construction and renovation. These requirements cover areas such as permit requirements, jurisdictional authority, energy standards, interpretation of code provisions, claims of exemption, and rights of appeal.

- The authority having jurisdiction (AHJ)<sup>1</sup> would ensure that all applicable buildings comply with requirements outlined in the code like permit requirements. This involves obtaining the necessary permits for building construction or renovation from the AHJ. The AHJ may also require compliance with specific energy standards and codes as outlined in the ECBC2023. NEEC act 2016 defines the responsibilities and functions of the federal and provincial governments for the efficient use of energy resources. Further, the 18<sup>th</sup> amendment has also empowered the provinces to make necessary arrangements for the implementation of such provisions like ECBC-2023.
- Interpretation of code provisions is another important requirement specified by the ECBC-2023. The AHJ is responsible for interpreting and enforcing the code provisions, which can include determining whether a building or system is in compliance with the code. In some cases, claims of exemption from the code provisions may be made. The ECBC-2023 specifies that the AHJ is responsible for reviewing and approving any such claims of exemption.
- ECBC-2023 specifies that building owners have the right to appeal any decisions made by the AHJ related to the enforcement of the code provisions. The AHJ is responsible for ensuring that the appeals process is fair and transparent, and that all appeals are handled promptly and professionally. The Energy Conservation Tribunal established as per the provisions of the NEEC Act 2016 would serve the purpose in this connection.

### 2.4 MANDATORY COMPLIANCE OF ECBC 2023

Given the significant impact that buildings have on energy consumption and greenhouse gas emissions, it is crucial that building owners and operators

---

1. The jurisdiction means area under the legal or administrative control of federal, provincial, and local governments; autonomous bodies and attached departments.

comply with the ECBC-2023. By making compliance mandatory for all applicable buildings, the code helps to ensure that energy efficiency and sustainability goals are pursued consistently and effectively across the building industry in Pakistan. This will help to reduce energy consumption, promote sustainability, and contribute to the overall development of a more sustainable and resilient built environment in Pakistan.

- The ECBC-2023 sets out minimum requirements for energy-efficient design and construction of buildings that are necessary for the energy-efficient operation of building systems and equipment.
- The plans and specifications for building construction be reviewed and approved by the appropriate sanctioning and development authorities/municipalities in accordance with the minimum requirements set out for energy efficient design and construction in the ECBC for energy conservation.
- The code makes compliance mandatory for all buildings mentioned in chapter-1. It specifies the buildings to which the code applies, including buildings with a total connected load of 50 kW or greater, or a contract demand of 75 kVA and/or greater, and/or a conditioned area of 200 m<sup>2</sup> or greater, and/or unconditioned buildings of covered area of 300 m<sup>2</sup> or more.
- The code applies to new buildings and their systems, new portions of existing buildings and their systems if the conditioned area or connected load exceeds the prescribed limits, new systems, and new equipment in existing buildings, and increases in electricity load beyond the prescribed limits.
- The code also applies to the retrofitting of conventional buildings to convert them into energy-efficient buildings.

## 2.5 COMPLIANCE DOCUMENTS

The compliance documents include all pertinent data and features of the building, its equipment, and systems in a level of detail that enables the authority having jurisdiction to verify compliance. The documents should be clear and comprehensive, leaving no room for ambiguity or uncertainty. These compliance documents must be prepared by the development authorities for their particular cities.

The purpose of requiring such detailed compliance documents is to facilitate effective enforcement of the ECBC-2023. If the documents are incomplete or insufficiently detailed, it would be difficult for the authority having jurisdiction to verify compliance, and this could lead to confusion, disputes, or non-compliance with the code. Therefore, it is crucial to ensure that compliance documents are carefully prepared and include all relevant information to make the compliance verification process as efficient and effective as possible. By doing so, the building owner or operator can avoid delays, penalties, or other consequences that may result from non-compliance with the ECBC-2023.

## 2.6 ENFORCEMENT OF ECBC 2023

ECBC 2023 is applicable in the whole country including AJK & GB simultaneously. ECBC-2023 defines the necessary documentation, inspections, and certifications to facilitate and enforce the energy provisions in buildings. For example,

- Building owners and operators are required to maintain records related to energy consumption, building systems, and equipment, and to make these records available for inspection upon request.
- Inspections are carried out by relevant authorities to ensure that the buildings are in compliance with the ECBC-2023.
- Penalties may be imposed for non-compliance with this code, in accordance with applicable laws and regulations.
- NEECA and PDAs may also suspend or revoke certifications, licenses, or permits if a building owner or operator fails to comply with this code as per the provisions of Section 10 and 13 of the NEEC Act 2016 respectively.

The enforcement of ECBC 2023 will help entities/ organizations to manage their energy use and energy consumption through Energy Management Systems (EnMS) following international standards like ISO 50001 or equivalent. The implementation or adaptation of energy management system automatically triggers the enforcement of the building energy code (and vice versa), which is in the interest of operators of large buildings as they consume a significant amount of energy. It provides a framework for identifying energy-saving opportunities, implementing energy-saving measures, and tracking energy performance. A brief concept and framework of EnMS is showcased in the chapter on Energy Management System under Chapter 12 of this code.

- The Federal Government as per the Section 10 of the NEEC Act 2016 in consultation with the Authority and National Standards Body where applicable may issue directions for the enforcement ECBC-2023 to conserve the energy in accordance with clause p, q & r of the said section.
- Further, the development authorities under the Federal Government or its Ministries like CDA, FWO, PWD would be responsible for the enforcement of ECBC-2023 in their jurisdictions. NEECA would facilitate the necessary amendments in their respective building bylaws to ensure effective Enforcement of ECBC-2023.
- The PDAs would issue necessary directions through their provincial governments as per the Section 13 of the NEEC Act 2016 for the enforcement and adoption of ECBC-2023 or any amendment version as per their local climatic conditions in accordance with clause a & b of the said section.

- The Provincial Building Control Departments, Development Authorities and Local Government Institutions like metropolitan corporations, municipal committees, town committees would adopt and enforce such directions related to ECBC-2023 issued by the PDAs through Provincial Governments and make amendments in their bylaws where necessary.

## **2.7 SUPPLEMENTARY INFORMATION**

The authority having jurisdiction has the right to ask for further information or documentation that may be necessary to verify that the building, equipment, and systems comply with the ECBC-2023. This additional information may include calculations, worksheets, compliance forms, manufacturer's literature, or any other relevant data.

The purpose of these supplementary documents is to provide the authority with sufficient detail to validate the compliance of the building with the ECBC-2023. The authority may use this information to conduct an assessment of the building, equipment, and systems to ensure that they meet the requirements of the Code.



# 3

## URBANIZATION AND DEVELOPMENTS

The "Urbanization and Developments" chapter of the ECBC-2023 promotes sustainable, compact urban development in Pakistan, focusing on energy-efficient building practices, green spaces, and efficient transportation to create eco-friendly, resilient urban environments.

## CHAPTER NO 3

# URBANIZATION AND DEVELOPMENTS

---

## 3.1 INTRODUCTION

The Urbanization and Developments chapter in the Energy Conservation Building Code 2023 (ECBC-2023) promotes sustainable urbanization and balanced size and vertical development practices. It emphasizes compact and mixed-use urban forms to accommodate population growth while minimizing sprawl and enhancing energy efficiency. The chapter provides guidelines for energy-efficient residential and commercial buildings, integrating green spaces and efficient transportation systems. By addressing the city size-vertical development-energy conservation relationship, it fosters livable, resilient, and eco-friendly urban environments in Pakistan.

## 3.2 PROBLEMS IN MAJOR CITIES OF PAKISTAN

### 3.2.1 High Energy Consumption

The average electricity consumption in major cities of Pakistan, as per the figures from the Power Planning and Monitoring Company (PPMC) report published in 2022, can vary significantly based on factors such as city size, population, industrial activities, commercial establishments, and residential energy usage. Karachi, being the largest city, has an estimated daily electricity consumption of around 2700 to 3500 megawatts (MW). Lahore, the second-largest city, consumes approximately 2300 to 2700 MW of electricity per day. The combined average electricity consumption for the twin cities of Islamabad and Rawalpindi is around 1300 to 1500 MW per day, while Faisalabad, a major industrial city, consumes about 1400 to 1700 MW per day of electricity on average. The high values of electrical consumption in major cities are attributed to irregular, unplanned, and large-scale expansion of urban areas, leading to the inefficient use of energy and other resources.

### 3.2.2 Population in Major Cities of Pakistan

As per the record of Pakistan Bureau of Statistics in September 2022, major cities in Pakistan have varying average populations. Karachi has an estimated average population of over 16.81 million, Lahore around 13.54 million, Islamabad approximately 1.198 million, Rawalpindi around 2.35 million, and Faisalabad

approximately 3.62 million. These large and highly populated cities present challenges for an underdeveloped country like Pakistan in fulfilling basic citizen needs, including essential services such as energy supply, sewerage, security, municipalities, and medical facilities.

### 3.2.3 Low Rise Constructions

The building bylaws of development authorities controlling low-rise residential (restricted to two to three story only) and commercial buildings (restricted to three story only in major cities like Islamabad) in Pakistan, along with their potential impact on resource inefficiency.

### 3.2.4 Improvements Proposed in the Building Bylaws

Following are improvement proposed in the building bylaws of development authorities controlling low-rise residential and commercial buildings in Pakistan:

**Building Height and Floor Area Ratio:** Building bylaws typically impose height and floor area ratio limits on low-rise buildings to regulate urban density and curb excessive resource consumption. However, these bylaws restrict high-rise construction in both residential and commercial areas, leading to horizontal sprawl and increased resource usage to meet citizens' needs. To promote sustainable development, the clause No: 2889(14)-78-80 of CDA building bylaws-2019 must be revised to encourage vertical development in Pakistan and allowing at least five story residential buildings and ten story commercial buildings with two basement floors dedicated for parking, fostering efficient land use and resource conservation.

**Zoning Regulations:** Bylaws establish zoning regulations to designate specific areas for residential and commercial purposes, ensuring efficient land use and resource management. However, the absence of mixed-use zoning in these regulations, developed by the development authorities, has resulted in segregated development, with distinct residential, commercial, and industrial zones. This segregation will lead to increased traffic congestion and longer commuting distances.

Furthermore, these regulations impose height restrictions in certain zones, hindering vertical development and limiting the potential for high-rise buildings, which are known to optimize land use and energy efficiency. Therefore, it is essential to revise Section 5-2889(57) of the CDA building bylaws, covering zoning regulations, while considering the best international practices mentioned above. Adopting such revisions by other development authorities across the country will ensure the efficient use of resources and promote sustainable development.

**Setbacks and Open Spaces:** Building bylaws define the necessary setbacks and open spaces around buildings to facilitate natural ventilation, daylighting, and green areas, thereby promoting energy efficiency and environmental sustainability. For instance, clause No: 2889(14)-127 of CDA building bylaws-2019 defines the setback requirements for different plot sizes. However, these setbacks reduce the living space and expose at least two to three walls to the sun, unlike non-detached

housing schemes that typically have only one front wall facing the sun and remaining three walls attached with the adjacent buildings. To ensure the efficient utilization of natural ventilation and minimize energy demand in such developments, clear guidelines for building envelope and insulation design are crucial. Therefore, it is necessary to revise the respective building bylaws and implement these guidelines to optimize the use of natural ventilation while maintaining energy efficiency in building design.

**Building Design and Orientation:** The housing authorities, controlled by local development authorities, have designed the layout plans of residential and commercial plots without prioritizing energy efficiency in design and building orientation. As a consequence, the majority of buildings in housing societies are directly exposed to the sun, leading to increased energy demand. The development authorities must revise their respective building bylaws to include specific guidelines for building design, envelop design and orientation to maximize natural lighting and minimize energy consumption for lighting and cooling. These guidelines are essential to promote sustainable practices and energy-efficient building construction in the housing developments.

**Seismic Zoning:** Pakistan is situated in a seismically active region, and it is divided into five seismic zones based on the likelihood of earthquakes as per the Seismic code of Pakistan developed by the PEC. High-rise construction in areas with higher seismic zones requires strict adherence to building codes and seismic design standards, similar to earthquake-prone countries like Japan as mentioned in the building codes of Japan, Seismic Provisions-2023. Architects and engineers must incorporate seismic-resistant features and technologies into the building's design to ensure structural integrity during earthquakes. For this purpose, the clause No: 2889(14)-136 and section 3.4.2 of CDA building bylaws structural calculation must be revised and demand and submit the structural drawings, structural models with seismic analysis and structural drawings with complete detailing for the user-friendly construction process for adopting such seismic design techniques, so that high-rise constructions can become safer and more resilient, mitigating potential earthquake impacts on the safety of occupants and the stability of structures. Promoting high-rise construction with these considerations will lead to more efficient resource utilization and better-prepared buildings in seismic-prone areas.

### 3.3 CITY SIZE FOR ENERGY EFFICIENCY AND CONSERVATION

The optimum size of cities plays a vital role in energy efficiency and conservation efforts, aligning with the objectives of the Energy Conservation Building Code (ECBC) of Pakistan. The ideal size of the smart large size city as adopted by the Kingdom of Saudi Arabia in development of Neom city is 26500 Km<sup>2</sup> while the size of the small city adopted by Pakistan for development of Ravi Urban City is 450 Km<sup>2</sup>. The following section highlights the optimum size of cities contributes to energy efficiency and conservation within the framework of the ECBC:

**Density and Compactness:** An optimal city size prioritize higher population densities and compact urban forms. Concentrating people, services, and amenities in a smaller area reduces the need for extensive transportation, leading to reduced



energy consumption and lower GHG emissions. Compact cities also promote walkability and the use of sustainable transportation modes, such as cycling and public transit.

**Efficient Resource Distribution:** An optimal city size allows for efficient distribution and utilization of resources. Infrastructure systems, including energy, water, and waste management, can be designed more effectively, reducing energy losses and promoting resource conservation. Centralized distribution networks, shared facilities, and compact development patterns enable the efficient provision of utilities and services.

**Sustainable Transportation:** Smaller, well-designed cities encourage sustainable transportation options. Compact urban forms reduce the distance between residences, workplaces, and amenities, making walking and cycling more feasible. Efficient public transportation systems can be developed, promoting the use of buses, trams, or trains and reducing the reliance on private vehicles, which contribute to air pollution and energy consumption.

**Mixed-Use Development:** Well-planned cities with mixed land uses enable shorter commutes, reducing energy consumption. Integrating residential, commercial, and institutional areas allows convenient access to daily needs, minimizing long-distance travel and associated energy use. Service-oriented efficient cities prioritize residents' well-being by optimizing public transportation, waste management, energy consumption, healthcare, and digital infrastructure using smart technologies. This approach enhances urban living, reduces environmental impact, and creates a resilient and future-ready urban landscape.

### 3.3.1 Factors Affecting the Size of Cities

Cities with populations between 500,000 and 2 million inhabitants offer manageable scales for efficient urban planning and infrastructure development. Implementing transportation systems, resource distribution, and waste management becomes easier. Effective decision-making and community engagement are also achievable in such cities. Factors like existing infrastructure, economic activities, environmental considerations, and future growth projections must be considered when determining a city's maximum size for energy-efficient development. Feasibility studies, stakeholder engagement, and international best practices such as Compact Development, Mixed-Use Zoning, TOD, Urban Green Spaces, Efficient Building Design, Retrofitting, Renewable Energy Integration, Smart Grid Technology, Energy Efficiency Incentives, Public Awareness, Data and Technology Integration, and Collaborative Partnerships help in making informed decisions tailored to each city's unique circumstances in Pakistan.

Determining the best suitable size of cities for Pakistan, considering existing infrastructure, economic activities, environmental considerations, and future growth projections, requires a comprehensive analysis of multiple factors. While there is no one-size-fits-all answer, a range of city sizes could be considered based on these factors. Here are some considerations to help propose a suitable size range:

**Existing Infrastructure:** Assess the capacity of existing infrastructure systems such as transportation networks, utilities, and public services. Consider the ability of the infrastructure to support a larger population and the potential for expansion or upgrades to accommodate future growth.

**Economic Activities:** Analyze the economic activities and industries that are dominant in the region. Determine whether there are specific industries that require a larger urban center for their growth and operation. Additionally, consider the potential for diversification and the development of new economic sectors that may influence the city size requirements.

**Environmental Considerations:** Evaluate the environmental impact and sustainability aspects of larger cities versus smaller cities. Consider factors such as energy consumption, water availability, waste management, air quality, and the preservation of natural resources. Determine the level of environmental strain that can be managed within different city sizes.

**Future Growth Projections:** Analyze the projected population growth and urbanization trends in the region. Consider demographic factors, migration patterns, and economic development forecasts. Evaluate the potential for accommodating future growth within different city sizes and their respective impacts on resource consumption and quality of life.

### 3.3.2 Size of the Cities

Taking these factors into account, a range of city sizes will be considered, such as:

#### 3.3.2.1 *Small to Medium-Sized Cities*

These cities will have populations ranging from a few hundred thousand to one million inhabitants. They will be suitable for regions with limited existing infrastructure, a focus on specific economic activities or industries, and where environmental considerations and sustainability are priorities. These cities will offer a balance between resource efficiency, community engagement, and environmental preservation. For fully resource-oriented cities the ideal size of the small to medium size cities will be 500 Km<sup>2</sup> to 800 Km<sup>2</sup>.

#### 3.3.2.2 *Medium to Large-Sized Cities*

These cities could have populations ranging from one to five million inhabitants. They would be suitable for regions with existing infrastructure capacity, diverse economic activities, and the potential for further growth. These cities can support a range of industries, provide a wide range of services and amenities, and offer opportunities for economic development while managing environmental impacts. For fully resource-oriented cities the ideal size of the medium to large size cities will be 1000 Km<sup>2</sup> to 2500 Km<sup>2</sup>.

### 3.3.2.3 Metropolitan Regions

Larger urban centers, with populations exceeding five million, are well-suited for regions with extensive infrastructure, diverse economic sectors, and high urbanization levels. These cities can function as regional hubs for commerce, education, healthcare, and culture. However, sustainable planning and practices are essential to manage environmental impact and maintain a high quality of life. The appropriate city size for Pakistan depends on each region's specific context, including existing conditions and future goals. Conducting detailed feasibility studies, stakeholder consultations, and comprehensive urban planning can determine the best city size range for balanced economic growth, efficient resource use, environmental sustainability, and an improved quality of life for residents. For fully resource-oriented cities the ideal size of the metropolitan cities will be 2500 Km<sup>2</sup> to 5000 Km<sup>2</sup>

## 3.4 VERTICAL DEVELOPMENT FOR ENERGY EFFICIENT BUILDINGS

Vertical development, involving multi-story buildings, enhances land use efficiency and creates denser urban environments. In energy conservation, it plays a pivotal role in promoting sustainability and reducing environmental impact. The Energy Conservation Building Code 2023 underscores the significance of vertical development to achieve energy efficiency goals. The code encourages the construction of five-story residential and ten-story commercial buildings with two basement floors dedicated for parking with seismic-resistant structures based on earthquake zones in Pakistan. By optimizing space utilization and adopting energy-saving measures, vertical development aligns with the ECBC-2023's objectives.

### 3.4.1 Impact of Low-Rise Construction

Low-rise construction, although commonly preferred for residential and certain commercial projects, presents challenges. The limited floor space in low-rise buildings is problematic for large-scale commercial or multi-family residential projects, resulting in less efficient land use and potential urban sprawl in densely populated areas. Additionally, low-rise construction fails to adequately address the need for high-density housing in urban centers, leading to increased pressure on infrastructure and potential housing shortages. Moreover, low-rise buildings spread horizontally, consuming more land compared to high-rise structures and contributing to the loss of green spaces and agricultural land. In suburban or rural areas, low-rise developments require extensive infrastructure networks, leading to higher development costs for local authorities. Furthermore, the larger surface area to volume ratio in low-rise buildings leads to increased heat loss during winters and heat gain during summers, resulting in higher energy consumption for heating and cooling. The prevalence of low-rise construction in suburban areas also leads to urban sprawl, causing increased traffic congestion and longer commutes.

To promote resource efficiency and sustainable development in Pakistan, building bylaws controlling low-rise residential construction must be revised to encourage high-rise construction for both residential and commercial buildings. Enforced and well-designed bylaws will prevent inefficient resource use, reduce environmental impact, and create a more sustainable and resilient built environment. Continuous updates and strict enforcement of these bylaws by local authorities are essential for effective resource management and sustainability in urban areas.

### 3.4.2 Energy Efficiency in Vertical Development

Energy efficiency in vertical buildings can be achieved through the utilization of natural resources, a crucial consideration during the design stage of both residential and commercial buildings. Harvesting natural resources in these structures plays a pivotal role in promoting sustainability and reducing reliance on external resources, thus minimizing the carbon footprint. The following aspects must be considered to ensure energy efficiency and conservation in the design of vertical buildings:

**Passive Design of Vertical Buildings:** Passive design principles for vertical buildings emphasize a sustainable approach to architecture, harnessing natural elements to create energy-efficient and comfortable spaces. These principles focus on optimizing building orientation, insulation, and shading to reduce the need for artificial heating and cooling. Strategically placed windows and openings allow for ample natural light and ventilation, while thermal mass materials help regulate indoor temperatures. By integrating these passive design strategies into vertical buildings, we can minimize energy consumption, lower carbon emissions, and create healthier, more environmentally friendly urban spaces that harmoniously coexist with their surroundings. For the design of building envelop and building insulation, passive design, refer to chapter no 4, Chapter no 5 and chapter no 6 of this code respectively.

**Solar Energy Harvesting:** Vertical buildings harness solar energy through the installation of solar panels on rooftops or facades. Photovoltaic (PV) systems convert sunlight into electricity, reducing the reliance on conventional energy sources and decreasing carbon emissions. Solar energy powers common areas, lighting, and some building systems. For the design of this system, refer to chapter no 14 of this code.

**Greywater Recycling:** Greywater refers to gently used water from activities like washing hands, showers, and laundry. Vertical buildings implement greywater recycling systems to treat and reuse this water for non-potable purposes such as toilet flushing or irrigation. Recycling greywater reduces the strain on freshwater resources and lowers water consumption. For the design of this system, refer to chapter no 17 of this code.

By implementing these natural resource harvesting techniques in vertical residential and commercial buildings, sustainable practices will be promoted. These strategies reduce energy consumption, minimize water usage, enhance indoor comfort, and contribute to the overall environmental performance of the building, fostering a more sustainable and resilient urban environment.



# 4

## BUILDING ENVELOPE

The building envelope, comprising the foundation, walls, windows, doors, roof, and insulation, acts as a barrier between indoor and outdoor environments. It plays a vital role in ensuring energy efficiency, maintaining indoor air quality, and providing comfort. This component is fundamental to the building's overall performance and sustainability.

## CHAPTER NO 4

# BUILDING ENVELOPE

---

## 4.1 INTRODUCTION

A building envelope, also known as a building enclosure or building shell, refers to the physical boundary or barrier between the interior and exterior of a building. It is typically made up of various components such as the foundation, walls, windows, doors, roof, and insulation, and is designed to provide protection against external weather conditions, maintain indoor climate control, and ensure energy efficiency. The building envelope plays a crucial role in maintaining indoor air quality, reducing noise pollution, and enhancing the overall comfort and health of building occupants. The building envelope is a crucial component of any structure, impacting its overall energy efficiency and conservation.

The Energy Conservation Building Code 2023 outlines specific requirements and design criteria to ensure the building envelope meets minimum standards for energy efficiency and conservation. This chapter provides an overview of the code's provisions for the building envelope and its surfaces, along with guidance on designing for improved energy performance. The building envelope needs to comply with mandatory provisions, and minimizing heat transfer should be prioritized in building design and material selection according to these criteria.

## 4.2 MANDATORY REQUIREMENTS

### 4.2.1 Building Envelope

The design of buildings, and selection of materials forming their surfaces, shall aim at reducing heat transfer from and into the buildings and adhere to the following criteria.

#### 4.2.1.1 External Walls and Roofs

The U-value, also known as the overall heat transfer coefficient, is a measure of a building material's ability to conduct heat. It indicates the rate of heat transfer through a specific material or building component, such as walls, roofs, or windows. The U-value is expressed in watts per square meter per Kelvin ( $W/m^2K$ ), and the lower the value, the better the insulation performance of the material. A low U-value means that the material has a high resistance to heat flow, which helps to reduce energy consumption and maintain comfortable indoor temperatures. Overall U values of external walls and roofs shall not exceed limits specified in Table 4.1.

Table 4-1: External Walls and Roof		
Sr. No	Building Components	U Values
1	Wall	U: 0.57 W/m <sup>2</sup> .K (0.100 Btu/h.ft <sup>2</sup> . °F)
2	Roof	U: 0.44 W/m <sup>2</sup> .K (0.078 Btu/h.ft <sup>2</sup> . °F)
<i>Source: International Energy Conservation Code (ICC-2021)</i>		

#### 4.2.1.2 Glass and Framing System

For buildings with external glass area, not exceeding 40% of the external wall area of the building, the overall U values and shading coefficient shall not exceed limits specified in Table 4.2.

Table 4-2: External Glass Area (≤40%)		
Sr. No	Coefficients	Values
1	Heat Transmission coefficient(U)	3.5 W/m <sup>2</sup> .K (0.44 Btu/h.ft <sup>2</sup> . °F)
2	Shading Coefficient (SC)	0.76
<i>Source: International Energy Conservation Code (ICC-2021)</i>		

For buildings with external glass area, in excess of 40% of the external wall area of the building, the overall U values and shading coefficient shall not exceed limits specified in Table 4.3.

Table 4-3: External Glass Area (>40%)		
Sr. No	Coefficients	Values
1	Heat Transmission Coefficient (U)	2.5 W/m <sup>2</sup> .K (0.37 Btu/h.ft <sup>2</sup> . °F)
2	Shading Coefficient (SC)	0.35
<i>Source: International Energy Conservation Code (ICC-2021) and Bangladesh National Building Code 2020 (BNBC-2020)</i>		

#### 4.2.2 Window to Wall Ratio

##### 4.2.2.1 For Mechanically Ventilated Building

For mechanically ventilated and cooled buildings of all occupancies, other than Hazardous and Storage, the Window to Wall ratio of building (WWRB), will be determined in conjunction with the glazing performance, as indicated by the Solar Heat Gain Coefficient (SHGC) or Shading Coefficient (SC) of the glass used. The relationship can be depicted in Figure 4.1.

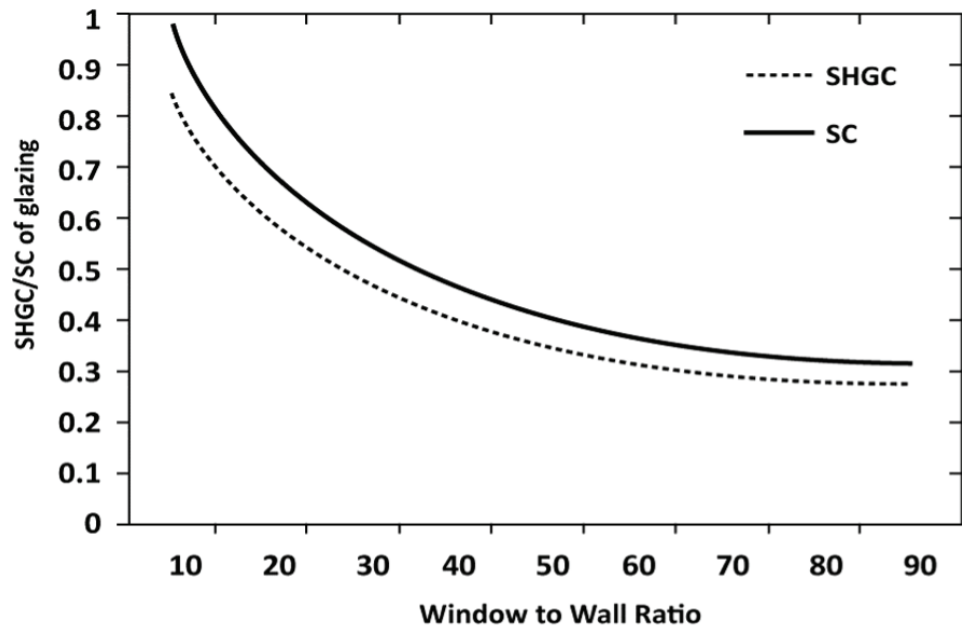

Figure 4-1. Selection of Glazing SHGC Based on WWR



The relationship can be explained in tabular form as shown in table 4.4.

<b>Table 4-4. Selection of Glazing SHGC Based on WWR</b>			
<b>Sr. No</b>	<b>WWR</b>	<b>SHGC</b>	<b>SC</b>
1	10	0.85	0.98
2	20	0.6	0.69
3	30	0.5	0.57
4	40	0.4	0.46
5	50	0.35	0.4
6	60	0.33	0.38
7	70	0.31	0.36
8	80	0.3	0.34
9	90	0.27	0.31

*Source: International Energy Conservation Code (ICC-2021)*

In all of the above cases, the Visible Light Transmittance (VLT) of the glazed element shall not be lower than thirty-five (35) percent.

<b>Table 4-5. SHGC and VLT for different WWR</b>			
<b>Sr. No</b>	<b>WWR</b>	<b>Maximum SHGC</b>	<b>Minimum VLT</b>
1	10	0.8	0.8
2	20	0.7	0.7
3	30	0.6	0.7
4	40	0.45	0.6
5	50	0.44	0.55
6	60	0.37	0.5
7	70	0.31	0.45
8	80	0.27	0.4
9	90	0.24	0.35

*Source: Prescribed Requirements, Philippine Green Building Code Project, May 2022*

For Air-conditioned buildings with external shading, permitted SGHC limit may be adjusted, but the increase shall not exceed values determined by Eq. 4.1 below:

$$\text{SHGC}_{\text{adj}} = \text{SHGC} + \text{A} \quad (4.1)$$

Where,  $\text{SHGC}_{\text{adj}}$  is the adjusted solar heat gain coefficient limit for windows with shading, SGHC is the Solar heat gain coefficient from table 4.4. and A is the SHGC correction factor for the external shading as per Table 4.4 or Table 4.5. For a window with overhang and fin, the value of A can be only used either from overhang or from fin.

### 4.2.3 Window Openings

Mechanically ventilated and cooled buildings of all occupancies, other than hazardous, retail and storage, shall have the provision of using natural ventilation for cooling and fresh air, in frequently occupied areas, with a fraction > 4% of the floor area being specified as openable windows. Openable balcony doors can be counted in this calculation. Note if the window area defined under Sec 4.2.3.1 is less than openable area, then fifty (50) percent of window area should be openable.

#### 4.2.3.1 For Naturally Ventilated Buildings

Naturally ventilated buildings of all occupancies, other than hazardous and storage, shall provide for fifty (50) percent of its window area to be openable.

#### 4.2.3.2 For all Openable Windows

All the openable windows above ground should be designed with safety measures in place such as protection hand rails for child safety.

#### 4.2.3.3 Windows on Exterior Wall

Windows to any regularly occupied space on exterior walls in naturally ventilated buildings shall be shaded conforming to Sec 4.5.

#### 4.2.3.4 High Performance Glass

High performance glass can be defined as Double or triple glazing with Low-E exterior glass and argon gas filled between the panes. U-factors usually range from a high of 1.3 (for a typical aluminum frame single glazed window) to a low of around 0.2 (for a multi-paned, high-performance window with low-emissivity coatings and insulated frames).

### 4.2.4 Shading

#### 4.2.4.1 Shadings for Naturally Ventilated Buildings

For naturally ventilated buildings of all occupancies, horizontal sunshades shall be provided over windows on South, East and West, the depth of which shall be calculated by multiplying the window height with a factor of 0.234 as shown in Figure 4.2. Horizontal louvers can be used instead of sunshades, in which case, depth of louver shall not be less than 0.234 times the gaps between the louvers as shown in Figure 4.3.

4.2.4.2 Vertical Shadings

Vertical Shading devices shall be provided on the West, depth of which shall be calculated, by multiplying the gaps between the vertical fins, or the window width if the shades border the window width, with a factor of 0.234 as shown in Figure 4.3 and Figure 4.4.

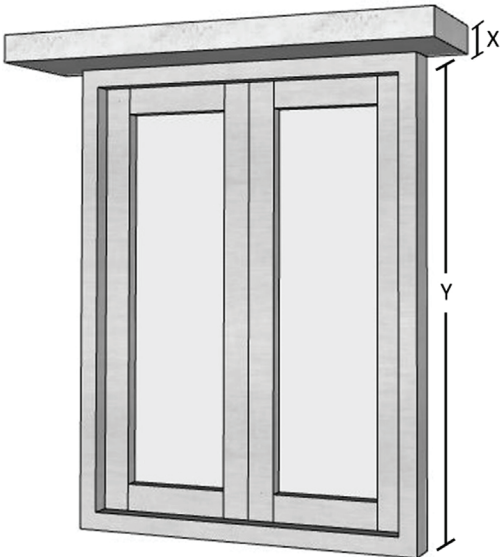

Figure 4-2: Horizontal Shade ( $x \geq 0.234y$ )

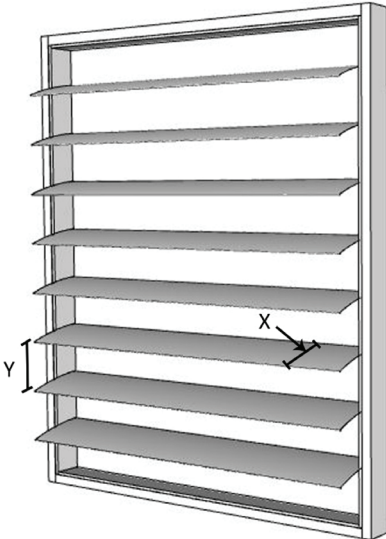

Figure 4-3: Horizontal Louvres  
(Relationship between depth (x) and gap (y):  $x \geq 0.234y$ )

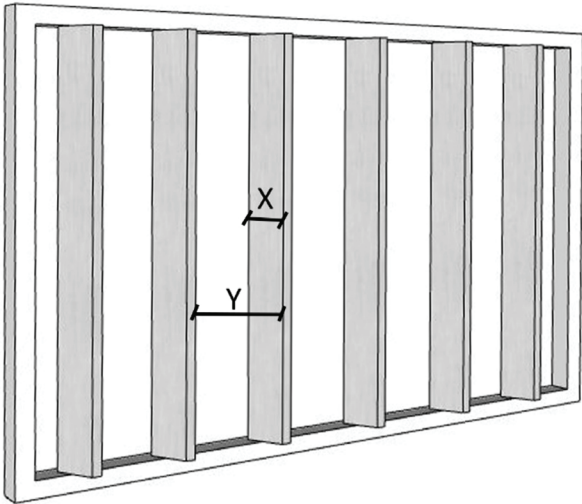

Figure 4-4: Vertical Shading or Louvres  
(Relationship Between Depth (x) and Gap (y):  $x \geq 0.234y$ )

#### 4.2.4.3 Exceptions

The above rule shall be relaxed if it can be demonstrated that shading is achieved by existing neighboring structures. The north side of all buildings are exempt from the above rules.

### 4.2.5 Roof Insulation and Green Roofing System

#### 4.2.5.1 Horizontal Exposed Roof Slab

Fifty (50) percent of horizontal exposed roof slabs of Buildings shall have green roofing system, to manage water run-off from roof tops, to control internal temperatures within the top floors and to reduce the energy consumption (carbon footprint) of the building. This shall not include any covered roof surface, e.g., solar panels, solar thermal heaters, machinery for mechanical or electrical systems, water tanks, etc. Stair loft or machine room tops will be exempt from this rule. The roof slab design shall consider structural support of the green roof system, with growing medium of minimum 300 mm. The design will indicate protection from dampness and provide a drainage system

#### 4.2.5.2 Horizontal Roof Slabs

Horizontal roof slabs, which are not covered by green roofing system, will have roof slabs with insulation, so that the time lag and decrement factor is greater than the other floor slabs of the building.

**Table 4-6: Roof Assembly U-factor (W/m<sup>2</sup>. K) Requirements for ECBC Compliant Building**

Building Types	Composite	Hot and Dry	Warm and Humid	Temperate	Cold
All building types, except below	0.33	0.33	0.33	0.33	0.28
School	0.47	0.47	0.47	0.47	0.33
Hospitality	0.2	0.2	0.2	0.2	0.2

Source: Bangladesh National Building Code 2020 (BNBC 2020)

### 4.2.6 Building Envelope Sealing

Following areas of the building envelope, of all except naturally ventilated buildings or spaces, shall be sealed, caulked, gasketed, or weather-stripped (Source: International Energy Conservation Code (ICC-2021):

- Joints around fenestration, skylights, and door frames.
- Openings between walls and foundations, and between walls and roof, and wall panels.
- Openings at penetrations of utility services through roofs, walls, and floors.
- Site-built fenestration and doors.
- Building assemblies used as ducts or plenums.
- All other openings in the building envelope.

- Exhaust fans shall be fitted with a sealing device such as a self-closing damper.
- Operable fenestration should be constructed to eliminate air leakages from fenestration frame and shutter frame.

#### 4.2.6.1 Air Leakage/ Infiltration

Revolving/sliding or swing doors shall be provided to minimize air infiltration in Vestibules/ lounges/ entrances as shown in figure 4.7.

Table 4-7: Air Leakage Values of Doors			
Sr. No	Air Leakages	L/s/m <sup>2</sup>	Cfm/ft <sup>2</sup>
1	Revolving/sliding/swing/exit door	5	1
2	Windows/doors	2	0.4

*(Source: International Energy Conservation Code (ICC-2021))*

Where,

**L/S/m<sup>2</sup>:** The airflow QΔP at a given pressure divided by the area of the pressure boundary A (e.g. the building enclosure area). Normalizing by enclosure area as opposed to the floor area allows for comparison with benchmarks and performance requirements.

**Cfm/ft<sup>2</sup>:** cubic feet of air per minute/square footage of the window

#### 4.2.7 Skylights

Skylights shall comply with the maximum U-factor and maximum Solar Heat Gain Coefficient (SHGC) requirements of Table 4.8. Skylight roof ratio (SRR), defined as the ratio of the total skylight area of the roof, measured to the outside of the frame, to the gross exterior roof area.

Table 4-8: Skylight U-factor and SHGC Requirements			
Climate	Maximum U-factor		Maximum SHGC
	W/m <sup>2</sup> .K	Btu/h·ft <sup>2</sup> ·F	
All climatic zones	4.25	0.746	0.35

*(Source: International Energy Conservation Code (ICC-2021))*

#### 4.2.8 Building Envelope Color

Light-colored building envelope, especially the roof areas which are the most vulnerable, can reduce heat transfer from the outside to the inside of the building by having surfaces with high Solar Reflectance Index (SRI). Building metal roof surfaces shall either be colored white or have a minimum SRI of 70 as shown in Table 4.9.

Sr. No	Metal Surface	SRI
1	Reflective white	86 to 92
2	Basic white	80 to 88
3	Beige / Tan	74 to 80
4	Dark brown	0 to 33
5	Light to medium brown	45 to 56
6	Light to medium grey	39 to 63
7	Dark grey	0 to 41
8	Blue	23 to 30
9	Light to medium blue	35 to 38
10	Red	28 to 36
11	Terracotta red	38 to 40
12	Green	25 to 32
13	Light to medium green	30 to 48

*Source: Solar Resource Report, World Bank Report, 2021 and PPG Cool Color Series - [www.coolcolorsdatabase.ppg.com](http://www.coolcolorsdatabase.ppg.com) as rated by the Cool Roof Rating Council, US, 2023.*

#### 4.2.9 Roof Insulation

Insulation can help reduce heat gain in a building thus improving thermal comfort, acoustic quality and reducing the load on the air conditioning system. This measure applies to all building occupancies as indicated in Table 4.10 showing the R-values of common roof insulation in ft<sup>2</sup>.°F. h/BTU, where BTU is British Thermal Units. Buildings shall be provided with roof insulation so that the average thermal resistance value (R-Value) of the roof is at least R-8.

Table 4-10: R-Value of Common Roof Insulation		
Sr. No	Insulation	R-Value / inch (25.4) mm)
1	Polyisocyanurate	5.6 to 8.0
2	Polyurethane	5.6 to 6.5
3	Closed cell spray foam	5.5 to 6.0
4	Phenolic foam	4.8
5	Urea formaldehyde foam	4.6
6	Plastic fiber	4.3
7	Mineral fiber	4.2 to 4.5
8	Cementitious foam	3.9
9	Polystyrene	3.8 to 5.0
10	Extruded polystyrene	5.0-4.8
11	Fiberglass	3.7
12	Rockwool	3.7
13	Rigid foam	3.6 to 6.7
14	Cellulose	3.6 to 3.8
15	Open cell spray foam	3.6
16	Sheep's wool	3.5
17	Hemp	3.5
18	Cotton	3.4
19	Loose cellulose	3.0 to 3.7
20	Mineral wool	2.8 to 3.7
21	Straw	2.4 to 3.0
22	Vermiculite / Perlite	2.4
23	Reflective bubble foil	1 to 1.1

*Source: U.S. Department of Energy Insulation Materials-2021.*

Table 4-11: Insulating Values of Common Building Materials				
Materials	R-Value (1/C)		R-Value Per inch (1/K)	
	ft <sup>2</sup> ·°F·h/BTU	m <sup>2</sup> ·K/W	ft <sup>2</sup> ·°F·h/BTU	m <sup>2</sup> ·°C/W
Metal Roof	0.04	0.00704	-	-
Aluminum Alloy	0.01	0.00176	-	-
Plastic Roof			-	-
Cement Tile Roof	0.21	0.03698	-	-
Clay Tile - 3 Inch [75mm] (1 Cell Deep)	0.8	0.14088	-	-
Asphalt Shingles	0.44	0.07748	-	-
Asphalt	-	-	0.12 to 0.34	0.02113 to 0.05987
Straw Thatch	-	-	2.04	0.35924
Fiberboard - 2/1 inch [12.5mm]	1.32	0.23245	-	-
Plywood - 2/1 inch [12.5mm]	0.62	0.10918	-	-
Plywood - 4/3 inch [18.75mm]	0.94	0.16553	-	-
Concrete (sand, gravel) 140 lb/cu ft [2246 kg/cu m]	-	-	0.05 to 0.11	0.00881 to 0.01937
Concrete (sand, gravel) 80 lb/cu ft [1283 kg/cu m]	-	-	0.24 to 0.30	0.04226 to 0.05283
Cement Mortar	-	-	0.1	0.01761
Stone	-	-	0.01	0.00176
Marble/Granite, Limestone	-	-	0.03 to 0.12	0.00528 to 0.02113
Ceramic Tile - 1 inch [25mm]	0.08	0.01409	-	-
Stone Tile - 1 inch [25mm]	0.05	0.00881	-	-
Air Space up to 4 inches [100mm]	1	0.1761	-	-
Inside Surface Air Film	0.61	0.10742	-	-
Exterior Surface Air Film	0.17	0.02994	-	-
Membrane	0.06 to 0.12	0.01057 to 0.02113	-	-
Soil (with %20 moisture content)	-	-	0.25 to 1.0	0.04403 to 0.1761
Sand - 2/1 inch [12.5mm]	0.1	0.01761	-	-

Source: The Philippines Green Building Code 2022



#### 4.2.10 Daylight

The daylighting of rooms is not only influenced by building and window design, but by urban design as well. The distance and height of neighboring buildings influences the amount of direct and diffuse daylight reaching the windows. The smaller the sky section that can be seen from a room through the window, the smaller the incidence of daylight will be.

##### 4.2.10.1 Spatial Daylight Autonomy (SDA)

SDA is a metric that defines a % of area that meets minimum daylight illuminance levels for a specified fraction of the working hours per year. In case of Leadership in Energy and Environmental Design (LEED) LEED-v4, SDA300/50% indicates that a certain percent of area must meet or exceed 300 lux for at least 50% of the working hours per year.

##### 4.2.10.2 Annual Sunlight Exposure (ASE)

ASE is a metric that identifies the potential for visual discomfort in interior work spaces. For LEED v4, no more than 10% of a space should have direct sunlight more than 1000 lux for a maximum period of 250 hours per year (ASE1000/250). A healthy balance between SDA and ASE can be achieved using design strategies to control glare such as shading devices.

Source: <https://www.firstgreen.co/services-green-buildings/>.

#### 4.2.11 Window and Skylight Design

The illuminance of rooms can be influenced by their size, location, orientation and shape of the openings. Skylights in a horizontal orientation are the most efficient for daylighting, as Figure 4.5 shows. This is because they face the full sky's hemisphere of 180°, receiving relatively high luminance from its zenith. For the standard room in Figure 4.5, the window area of a skylight need only be 20% of the floor area for a daylight factor of 5%, compared to 50–60% for vertical openings in roofs or walls. Because of their high daylighting efficiency, horizontal skylights should be used predominantly whenever possible. However, as they cannot provide an adequate view out, windows at eye level also need to be located in the walls.

Identical room-dimensions. Ratio of window area to floor area (KF) for mean daylight factor of 5% varies from 0.2 to 0.8.

For vertical windows in walls, the right mix of orientation to the sun is important. For thick walls, the sides of the window openings should be slanted, with the inner opening being larger than the outer one. Surfaces of the reveal and sill of the window should be reflective (light colors). The higher windows are located in the wall, the further into its center will the room be illuminated. Window openings below desk level do not contribute to room illumination, but may be important for the view from high rise.

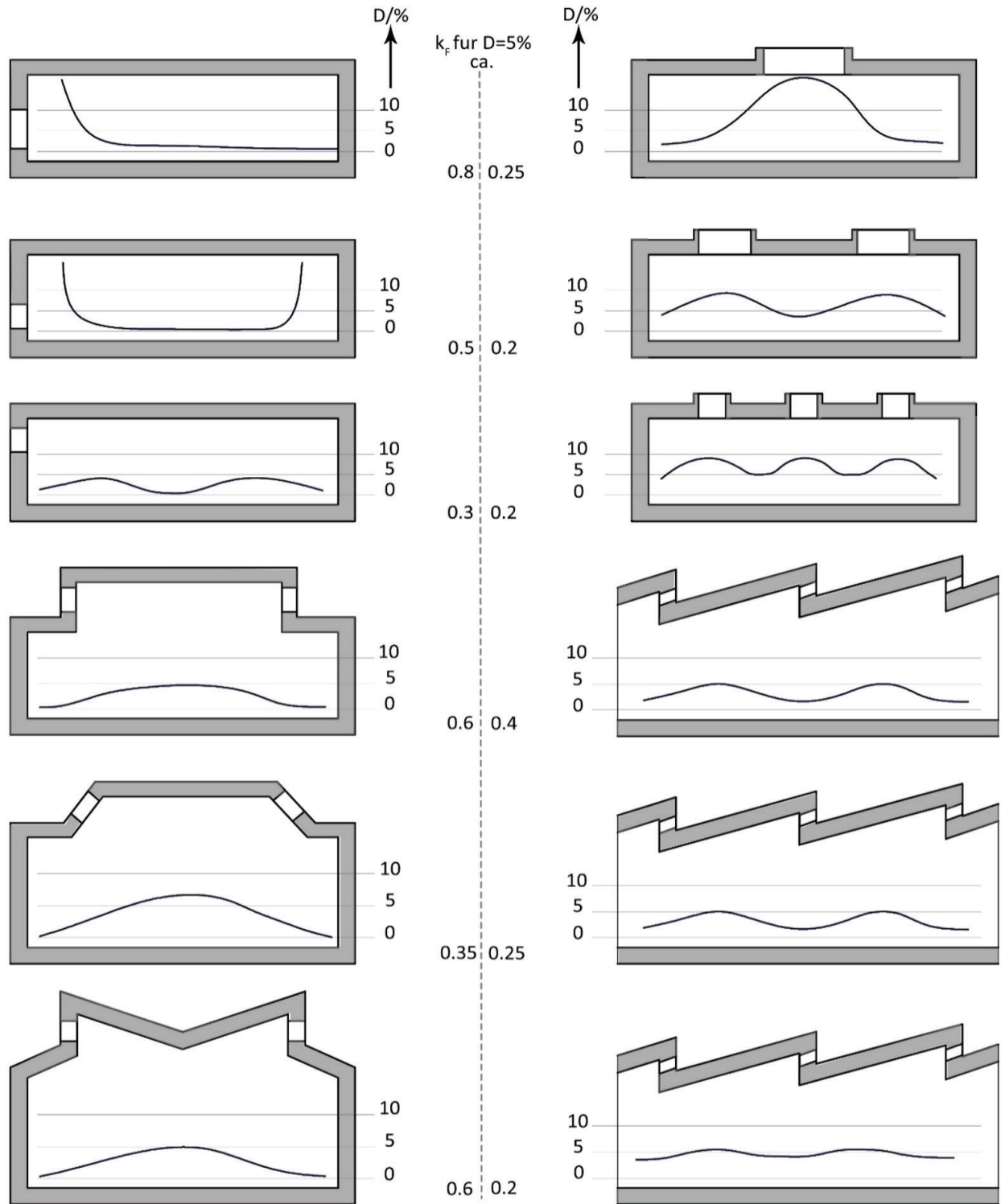

Figure 4-5: Influence of Windows and Skylights on Daylight Factor

The window area should be sufficient for daylighting; however, fully glazed façades are not the optimum. Glazed façade areas of more than 40 to 60% do not improve daylighting and tend to create glare and solar heat gain problems. Clerestory windows are placed in the upper part of walls above eye level in order to improve the illumination of the room's center. They can be tailor-made for daylighting performance, as a view of the outside is offered by windows in lower positions, which can be completely separate. Often, light shelves or other light directing devices are integrated into clerestory windows.

Source: <https://www.sciencedirect.com/topics/engineering/daylighting>

#### 4.2.12 Window to Wall Ratio in Fenestrations

Fenestration is defined as “all areas (including the frames) in the building envelope that let in light, including windows, plastic panels, clerestories, skylights, doors that are more than one-half glass, and glass block walls.”

Table 4-12: Windows to Wall Ratio in Fenestrations		
Sr. No	Areas of Fenestrations	Windows to Wall Ratio in Fenestrations
1	Total vertical fenestration areas	> 40% of the gross wall area
2	Total skylight area	> 5% of the gross roof area”

*Source: Prescriptive building envelope requirements of ASHRAE 90.1-2017, Section 5.5.4.2.*

Similar requirements exist in the International Energy Conservation Code-2019 (IECC-2019). Under the prescriptive building envelope requirements, Section 502.3.1 Maximum Area states that the vertical fenestration area shall not exceed 40% of the gross wall area and that skylights shall not exceed 3% of the gross roof area. And there are similar requirements in the Washington State Energy Code-2019 (WSEC-2019), although there is a subtle but importance difference. Under the prescriptive building envelope requirements, Section 13.2.3 states that the percentage of total glazing relative to the gross exterior wall areas shall not be greater than 40% for the vertical glazing and overhead glazing.

Although the requirement is specified in terms of glazing and not fenestration, the definition of glazing in the WSEC-2019 is similar to the definition of fenestration in ASHRAE 90.1-2007 except that the WSEC-2019 does not specifically mention plastic panels and the threshold of glass in doors is not specified. However, the requirement is in terms of total glazing, which includes skylights. Skylights are included in the glazing area even though they are not counted as part of the gross exterior wall area. This has the effect of further limiting vertical glazing areas on buildings when there is also a significant skylight area.

### 4.3 COMPLIANCE DOCUMENTATION

Compliance documents should include plans, drawings, specifications, and other relevant documentation that demonstrate compliance with the Energy Conservation Building Code 2023 and roles and regulations of relevant authorities. These documents should be submitted to the relevant authorities for review and approval.

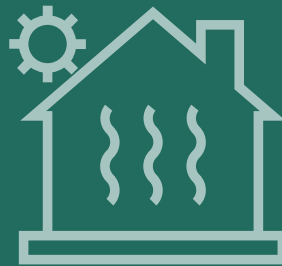

# 5

## PASSIVE BUILDING DESIGN

This chapter emphasizes the importance of passive design measures in new constructions for energy efficiency, particularly in hot and humid climates where cooling is a major energy consumer. It focuses on reducing heat gain and enhancing natural cooling through methods like landscaping and shading, underscoring the need to consider the surrounding environment in building design.

## CHAPTER NO 5

# PASSIVE BUILDING DESIGN

---

## 5.1 INTRODUCTION

Adopting passive design measures is an economical approach to enhancing energy efficiency in both residential and commercial buildings. Almost half of energy consumption is utilized for cooling purposes in hot and humid climates. As a result, the measures outlined in this chapter should be given priority and employed to the fullest extent possible. To optimize passive cooling strategies, adopting passive design measures, which are primarily architectural, makes sense. Passive design measures aim to reduce heat gain within buildings and improve environmental cooling through natural methods such as landscaping, vegetation, and shading.

The purpose of this chapter is to provide minimum requirements for the new construction to ensure Energy Efficiency through Passive Design Techniques. Since buildings are primarily designed to provide comfortable internal environments for occupants, passive design measures must take the building's surrounding environment into account. The essential passive design measures are discussed below.

## 5.2 APPLICABLE BUILDING SYSTEM

The provisions of this code shall apply to the Building Envelopes, Building Orientation, Water System (WS), Lighting, and Ventilation design of the buildings.

### 5.2.1 Exemptions

The code shall apply to independent housing units only. The code shall not apply to the old constructed village and rural area construction and high-rise buildings, commercial buildings, office buildings.

### 5.2.2 Safety, Health and Environmental codes take precedence

Wherever this code is found to be in conflict with safety, health, or environmental codes, the safety, health, or environmental codes shall take precedence.

## **5.3 ADMINISTRATION AND ENFORCEMENT FOR PASSIVE BUILDING DESIGN**

### **5.3.1 Compliance Requirements**

Building Code serve as a guideline for AEC-professionals: Architects, Engineers and Consultants. Compliance of building codes is mandatory for user's security and making efficient building structures. Review and approval of building plans and specifications by respective sanctioning and development authorities / municipalities is mandatory.

The compliance requirement include:

- Implementation of recommended R-value for thermal performance in walls and roofs must be met.
- According to the Regional climatic zone, Passive techniques must be implemented.
- Installation of efficient heating, cooling and lighting systems to minimize electricity loads.
- Use of renewable energy systems should be encouraged in the designing phase of buildings.

### **5.3.2 Mandatory Requirements**

The submission of building plans to the development authorities must be done in the form of BIM (Building Information Modelling) models with an detailed energy analysis. The BIM models must illustrate the energy efficiency before and after the implementation of passive strategies or building energy codes. The improvement in energy efficiency should be at least 50%. During the construction phase, it is necessary to document the progress through photographs.

## **5.4 BUILDING ENVELOPE**

Refer to Chapter 4 of this code (Energy Conservation Building Code 2023) for complete guideline on the design of building envelope.

### **5.4.1 External Walls and Roof**

External walls must have a minimum R Value (m<sup>2</sup> K/W) of 13-15. Roof should have a minimum R Value of 30. While 9" Masonry wall has R value 3.96. There are variety of materials available in the market that can help achieve the Recommended R Value.

### **5.4.2 Glass and Shading Devices**

The windows must be properly shaded and insulated to minimize the heat exchange and achieve the R-values as mentioned in the section 5.4.1.

### 5.4.3 Air Leakage/Infiltration

The building envelope shall be durably sealed, caulked, gasketed or weather-stripped to minimize air leakages wherever the tendency exists.

## 5.5 BUILDING ORIENTATION

Building orientation is an important factor in the energy efficiency and sustainability of a building. By properly orienting a building, it is possible to take advantage of natural light and ventilation, reduce the need for artificial heating and cooling, and minimize the building's overall energy consumption.

Building Orientation includes Building Placement on the site, positioning of the windows, shades and other features. Orientation must be planned to take maximum advantage of the daily and seasonal variations of the sun's radiation. Optimum orientation of a structure is, in the end, a compromise between its function, its location, and the prevailing environmental factors of heat, light, humidity, and wind.

A compact building shape and appropriate building orientation can reduce the energy consumption for heating and cooling systems up to 50% to 80% depending on the geographical conditions where the building is located. Building by laws must be designed in a way, that allows the AEC; Architects; Engineers and consultants to orient building in way through which maximum efficiency can be achieved.

- Maximum covered area of Ground Floor cannot exceed 75% area of the Plot.
- The addition of courtyards at the strategic locations in the building to maintain the microclimate of the structure.
- Architects should optimize the utilization of open spaces to achieve energy efficiency in buildings through passive design.
- Existing Bylaws must be changed in order to give the AEC; Architects, Engineers and consultants full control of land use to ensure optimal building orientation.

## 5.6 WATER SYSTEM DESIGN (WSD)

### 5.6.1 General

All service water heating equipment and systems shall comply with the mandatory requirements of this section.

### 5.6.2 Mandatory Requirements

#### 5.6.2.1 Piping Insulation

The details of the piping insulation are mentioned in the below Table 5.1.

Table 5-1: Piping Insulation for Water System Design								
Fluid Design Operating Temperature Range (°F)	Insulation Conductivity			Nominal Pipe or Tube Size (in)				
	Conductivity (Btu.in / (h.ft2.°F)	Mean Rating Temperature (°F)		< 1	1 to <1-1/2	1-1/2 to <4	4 to <8	≥ 8
<b>Heating Systems (Steam, Steam Condensate and Hot Water)</b>								
> 350	0.32 – 0.34		250	2.5	3	3	4	4
251	- 350	0.29 – 0.32	200	1.5	2.5	3	3	3
201	- 250	0.27 – 0.30	150	1.5	1.5	2	2	2
141	- 200	0.25 – 0.29	125	1	1	1	1.5	1.5
105	- 140	0.22 – 0.26	100	0.5	0.5	1	1	1
<b>Domestic and Service Hot Water Systems</b>								
105+	0.22 – 0.28		100	0.5	0.5	1	1	1
<b>Cooling Systems (Chilled Water, Brine and Refrigerant) d</b>								
40	- 46	0.22 – 0.28	100	0.5	0.5	1	1	1
< 40	0.22 – 0.28		100	0.5	1	1	1	1.5

For insulation outside the stated conductivity range, the minimum thickness (T) shall be determined as follows:

$$T = r \{1 + t/r\} K/k - 1 \quad \text{Eqn 5-1}$$

Where,

T = minimum insulation thickness (in),

r = actual outside radius of pipe (in),

t = insulation thickness listed in this table for applicable fluid temperature and pipe size,

K = conductivity of alternate material at mean rating temperature indicated for the applicable fluid temperature (Btu.in. [h-ft2. °F]) and

k = the upper value of the conductivity range listed in this table for the applicable fluid temperature.

These thicknesses are based on energy efficiency considerations only. Additional insulation is sometimes requiring relative to safety issues/surface temperature.

Piping insulation is not required between the control valve and coil on run-outs when the control valve is located within 4 ft of the coil and the pipe size is 1 in or less. These thicknesses are based on energy efficiency considerations only. Issues such as water vapor permeability or surface condensation sometimes require vapor retarders or additional insulation.

### 5.6.2.2 Equipment Efficiency

Service water heating equipment shall meet or exceed the minimum efficiency requirements presented in Table 5.2.



Table 5-2: Performance Requirements for Water Heating Equipment				
Equipment Type	Size Category (Input)	Subcategory or Rating Condition	Performance Required <sup>a</sup>	Test Procedure <sup>b</sup>
Electric Water Heaters	≤12kW	Resistance ≥20 gal	0.93-0.00132V EF	DOE 10CFR Part 430
	>12kW	Resistance≥20 gal	20 + 35 $\sqrt{V}$ SL, Btu/h	ANSI Z21.10.3
	≤24 Amps and ≤250 Volts	Heat Pump	0.93-0.00 132V EF	DOE 10CFR Part 430
Gas Storage Water Heaters	≤75,000 Btu/h	≥20 gal	0.62-0.0019V EF	DOE 10 CFR Part 430
	>75,000 Btu/h	<4000 (Btu/h)/gal	80% $E_t$ (Q/800 + 110 $\sqrt{V}$ ) SL, Btu/h	ANSI Z21.1 0.3
Gas Instantaneous Water Heaters	>50,000 Btu/h & <200,000 Btu/h	≥4000 (Btu/h)/gal and <2 gal	0.62-0.0019V EF	DOE 10CFR Part 430
	≥200,000 Btu/h <sup>c</sup>	≥4000 (Btu/h)/gal and <10 gal	80% $E_t$	ANSI Z21.10.3
	≥200,000 Btu/h	≥4000 (Btu/h)/gal and ≥10 gal	80% $E_t$ (Q/800 + 110 $\sqrt{V}$ ) SL, Btu/h	
Oil Storage Water Heaters	≤105,000 Btu/h	≥20 gal	0.59-0.0019V EF	DOE 10 CFR Part 430
	>105,000 Btu/h	≥4000 (Btu/h)/gal	78% $E_t$ (Q/800 + 110 $\sqrt{V}$ ) SL, Btu/h	ANSI Z21.10.3
Oil Instantaneous Water Heaters	≤21 0,000 Btu/h	≥4000 (Btu/h)/gal and <2 gal	0.59-0.00 19V EF	DOE 10CFR Part 430
	>210,000 Btu/h	≥4000 (Btu/h)/gal and <10 gal	80% $E_t$	ANSI Z21.1 0.3
	>210,000 Btu/h	≥4000 (Btu/h)/gal and ≥ 10 gal	78% $E_t$ (Q/800 + 110 $\sqrt{V}$ ) SL, Btu/h	
Hot Water Supply Boilers, Gas and Oil	≥300,000 Btu/h and <12,500,000 Btu/h	≥4000 (Btu/h)/gal and <10 gal	80% $E_t$	ANSI Z21.10.3
Hot Water Supply Boilers, Gas	-	≥4000 (Btu/h)/gal and ≥ 10 gal	80% $E_t$ (Q/800 + 110 $\sqrt{V}$ ) SL, Btu/h	
Hot Water Supply Boilers, Oil	-	≥4000 (Btu/h)/gal and ≥10 gal	78% $E_t$ (Q/800 + 110 $\sqrt{V}$ ) SL, Btu/h	
Pool Heaters Oil and Gas	All	-	78% $E_t$	ASHRAE 146
Heat Pump Pool Heaters	All	-	4.0 COP	ASHRAE 146
Unfired Storage Tanks	All	-	R-12.5	(none)

- Energy factor (EF) and thermal efficiency (EI) are minimum requirements, while standby loss (SL) is maximum Btu/h based on a 70 °F temperature difference between stored water and ambient requirements. In the EF equation, V is the rated volume in gallons. In the SL equation, V is the rated volume in gallons and Q is the nameplate input rate in Btu/h
- ASHRAE 90.1 – 2004 contains a complete specification, including the year version, of the referenced test procedure.
- Instantaneous water heaters with input rates below 200,000 Btu/h must comply with these requirements if the water heater is designed to heat water to temperatures 180 °F or higher.

### 5.6.3 Voluntary Adoption

Building with a centralized system may have heat recovery units. The use of solar/ renewable energy for water heating is also recommended for adoption by the buildings with centralized and non-centralized systems. Residential facilities of 420 m<sup>2</sup> (4300 sq. ft) or greater plot area, commercial building, hotels and hospitals with centralized system may have solar / renewable energy for water heating at least one fifth of the design capacity.

### 5.6.4 Compliance Documentation

Compliance documents should include plans, drawings, specifications, and other relevant documentation that demonstrate compliance with the relevant building codes and regulations. These documents should be submitted to the relevant authorities for review and approval.

## 5.7 LIGHTING

Interior and exterior Lighting scheme should comply with NECCA labelling regime.

## 5.8 VENTILATION

### 5.8.1 General Ventilation Requirements

All residential buildings must be designed and constructed with adequate ventilation systems to ensure a healthy and comfortable indoor environment. The minimum ventilation rate should be at least 8 liters per second per person. For the ventilation in the commercial building refer to ASHREA 62.1 where it is mentioned that the minimum ventilation rate for commercial building for the breathing space should be 3.8-4.5 liters per second per person.

### 5.8.2 Natural Ventilation

Residential buildings should be designed to allow for natural ventilation wherever possible. This can be achieved through the use of windows, vents, or other openings that can be controlled to regulate the amount of air flow. In order

to maximize natural ventilation, buildings should be oriented to take advantage of prevailing winds and should be designed to minimize obstructions to air flow.

Ventilation, or the movement of air, serves three essential functions:

- i. It supplies the required fresh air to occupants of a building.
- ii. It helps maintain the thermal comfort of building occupants.
- iii. It reduces the temperature of the interior space when outdoor air is cooler.

**ASHRAE Standard 62.1** - Ventilation for Acceptable Indoor Air Quality - outlines the necessary ventilation requirements. From an energy efficiency perspective, properly conditioning ventilation air can be costly, especially in hot and humid regions. It requires cleaning, drying, cooling, and distributing outdoor air to the breathing zone, all of which are expensive processes. Despite this, it is essential to introduce outdoor air to air-conditioned spaces for health reasons. During specific periods, such as mornings and evenings, natural ventilation can effectively cool offices and other areas with fresh air. During these times, air flushing of building spaces can be considered. However, security, ambient exterior noise levels, outdoor air quality, outdoor air temperatures, humidity, weather conditions, and other factors should also be taken into account. There are two methods for implementing natural ventilation:

#### 5.8.2.1 Cross ventilation (wind-driven)

Figure 5.1 illustrates cross ventilation, which involves the flow of air across a building space through windows, driven by wind.

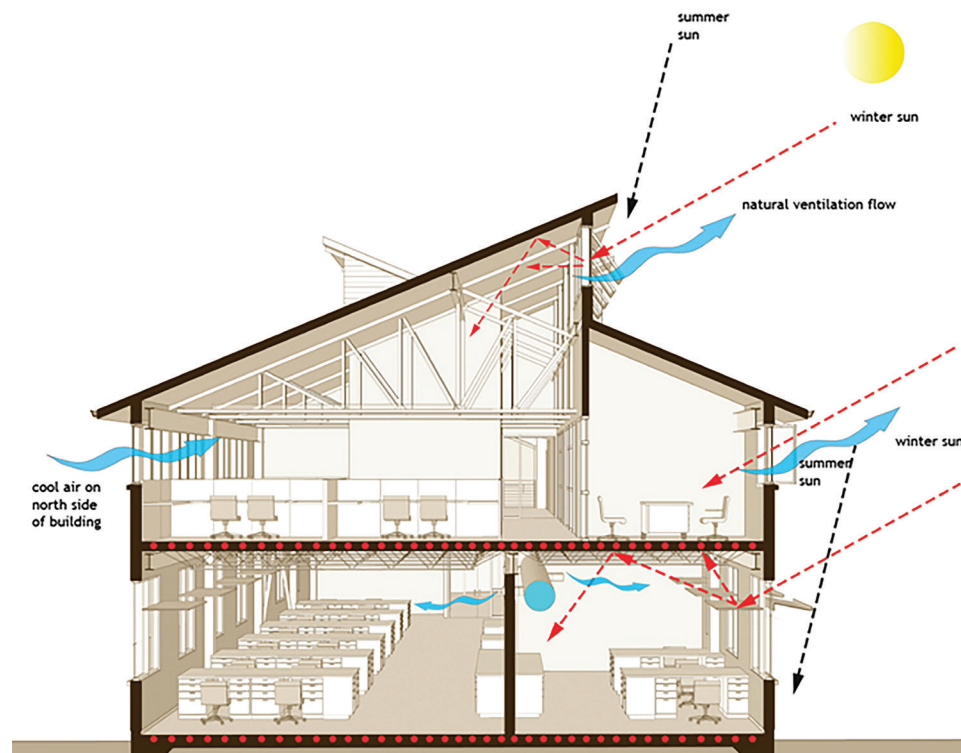

**Figure 5-1. Building Section Showing Cross Ventilation**

### 5.8.2.2 Stack Ventilation (buoyancy driven)

Figure 5.2 depicts stack ventilation, which is buoyancy-driven and is typically utilized in high-rise buildings through void spaces or atriums.

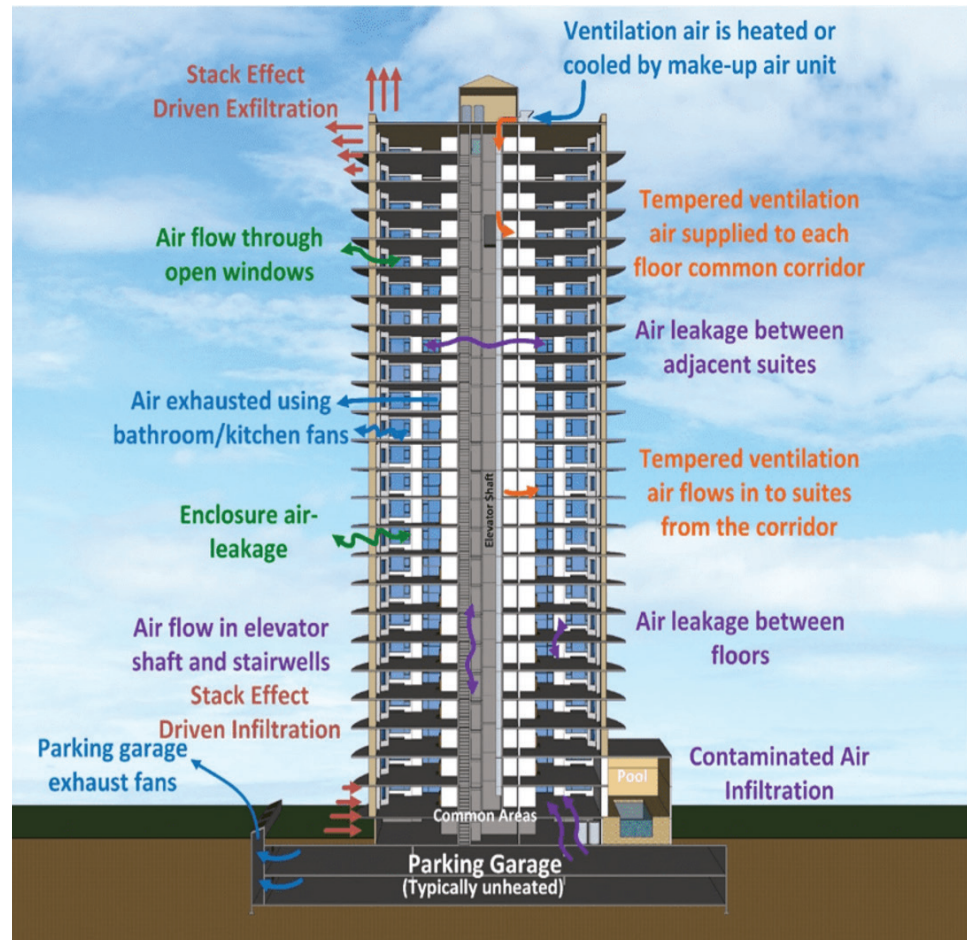

**Figure 5-2. High-rise Building Section Showing Stack Ventilation**

Overview of components of airflow and ventilation in a multi-unit building (Source: RDH Building Science-2023 <https://www.rdh.com/>).

### 5.8.3 Mechanical Ventilation

In cases where natural ventilation is not possible or sufficient, mechanical ventilation systems may be used. These systems should be designed to provide a minimum of 8 air changes per hour. The ventilation systems should be properly maintained and regularly inspected to ensure they are functioning properly.

### 5.8.4 Air Quality

The ventilation system should be designed to ensure that the air quality is maintained at an acceptable level. This can be achieved through the use of filters or other air cleaning devices, as necessary.

### 5.8.5 Exhaust Ventilation

In spaces where pollutants are generated, such as kitchens and bathrooms, exhaust ventilation systems should be installed. These systems should be designed to effectively remove the pollutants from the space and discharge them to the outdoors.

### 5.8.6 Noise Control

The ventilation system should be designed to operate at a noise level that is acceptable for residential use.

## 5.9 SITE PLANNING AND ORIENTATION

When designing a new building on open land, it is crucial to consider site planning and orientation. In equatorial regions, the primary goal of proper orientation is to avoid exposing building openings to intense solar radiation as the sun moves from east to west. As a general guideline, the building layout should be oriented in such a way that the main long axis, with more openings or glazing, faces north to south, while the narrow ends of the building face the east-west direction (as shown in Figure 5.3 and Figure 5.4). The objective is to minimize the exposure of building openings to the east-west direction of the movement of sun as much as possible.

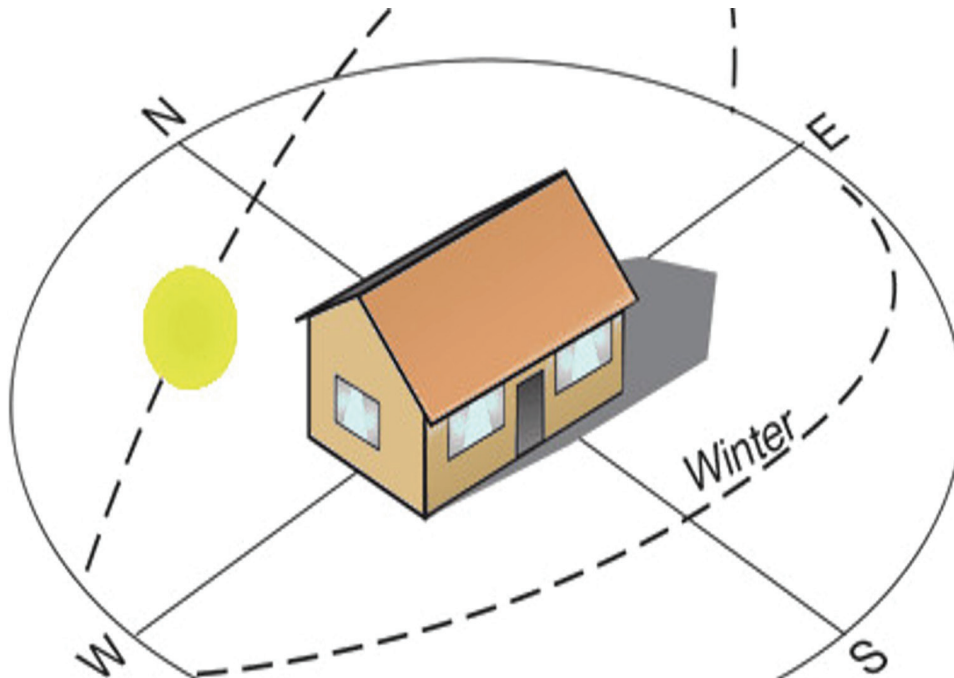

**Figure 5-3. Longer Axis of Building Should Face North and South as Much as Possible**

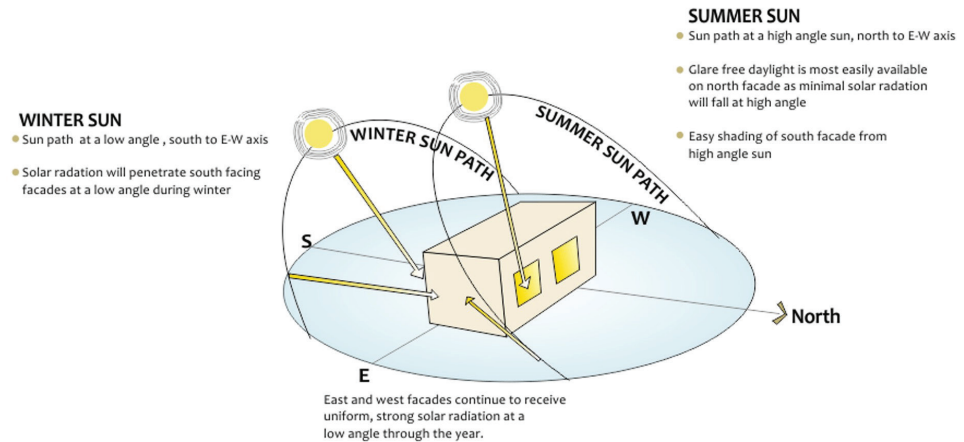

**Figure 5-4. Longer Axis of Building Should Face North and South as Much as Possible**

The orientation of buildings can also have an impact on the immediate microclimate of open spaces by providing shade and shadow to the surrounding areas. This can be beneficial to the adjacent indoor spaces, helping to regulate their temperature and provide a more comfortable environment.

### 5.9.1 Daylighting

Before considering efficient electrical lighting, it is essential to incorporate daylight harvesting in a building to fulfill the lighting requirements during the daytime, where possible. A well-designed daylight harvesting system can benefit the building occupants by providing a comfortable working environment and improving energy efficiency. On the other hand, a poorly designed system can cause discomfort due to glare, excessive heat gain, increased thermal discomfort, and high energy consumption in buildings.

$$DF = \frac{E(\text{internal})}{E(\text{external})} \times 100 \quad (\text{Eqn 5-2})$$

Where:

DF = daylight factor (%)

E(internal) = horizontal illumination of reference point indoor (Lux)

E(external) = horizontal illumination of unobstructed point outdoor in an overcast sky condition (Lux)

The daylight factor (DF) is a straightforward way to describe daylight distribution, penetration, and intensity. It is expressed as a percentage and represents the ratio of the internal space illuminance ( $E_{\text{internal}}$ ) at a point in a room to the instantaneous external illuminance ( $E_{\text{external}}$ ) on a horizontal surface (as shown in equation 2).

As a general guideline, the brightness levels and distribution within a building can be broadly categorized based on the daylight factors described in Table 5.3. A recommended range of daylight factor is 1.0-3.5. Incorporating daylighting into a design of building can lead to energy savings by reducing the need for artificial electrical lighting, which in turn reduces lighting energy emissions that need to be removed by the air-conditioning and mechanical ventilation (ACMV) system.

Table 5-3. Daylight Factors and Impact				
Daylight Factor	Lighting	Glare	Thermal Comfort	Appearance and Energy Implication
> 6.0	Intolerable	Intolerable	Uncomfortable	The room appears strongly daylit. Artificial lighting is rarely needed during the day, but thermal problems due to solar heat gains and glare may occur.
3.5–6.0	Tolerable	Uncomfortable	Tolerable	
1.0–3.5	Acceptable	Acceptable	Acceptable	The room appears moderately daylit. It is generally a good balance between lighting and thermal aspects. Supplementary artificial lighting may be needed in dark areas due to the effect of layout or furniture arrangement.
< 1.0	Perceptible	Imperceptible	Acceptable	The room looks gloomy; artificial lighting is needed most of the time.

*(Source: Malaysian Standards for daylight-2021)*

### 5.9.2 Façade Design in Building Envelope

The design of a building's façade is a crucial element in implementing passive design measures. It offers architects the opportunity to incorporate innovative ideas to minimize solar heat gains in the building. The façade is the external envelope of a building that not only defines its form and aesthetics but can also optimize daylighting and thermal comfort by reducing solar heat gains with the help of architectural treatments and appropriate materials.

To prevent heat from entering the building through conduction and solar radiation, the building envelope should be designed to act as a barrier. A well-designed envelope can significantly reduce the cooling load and, as a result, the energy consumption of the building. A design criterion called Overall Thermal Transfer Value (OTTV) is one way to measure the performance of a building envelope. This criterion is particularly useful for non-air-conditioned and partially air-conditioned buildings. Its objective is to optimize the design of the building envelope to minimize external heat gain, which in turn reduces the cooling load of the ACMV system.

A maximum value of  $50 \text{ W/m}^2$  is recommended for the OTTV of a building envelope. However, stakeholders should deliberate on this value and the National Energy Efficiency and Conservation Authority (NEECA) should ultimately decide whether to adopt a higher energy efficiency goal, as there may be cost implications for such a decision. For the purpose of this report, the maximum OTTV value for a commercial building is set at  $50 \text{ W/m}^2$  and OTTV of the residential buildings in Malaysia varied from  $35$  to  $65 \text{ W/m}^2$  with a mean value of  $41.7 \text{ W/m}^2$ . The OTTV is calculated based on all external walls of the building. Achieving an OTTV not exceeding  $50 \text{ W/m}^2$  confirms that the building envelope design incorporates measures to minimize external heat gain, which in turn reduces the cooling load of the ACMV system. Such efforts will also result in a decrease in the required capacity of the ACMV equipment.

The shading design of the main façade are shown follows:

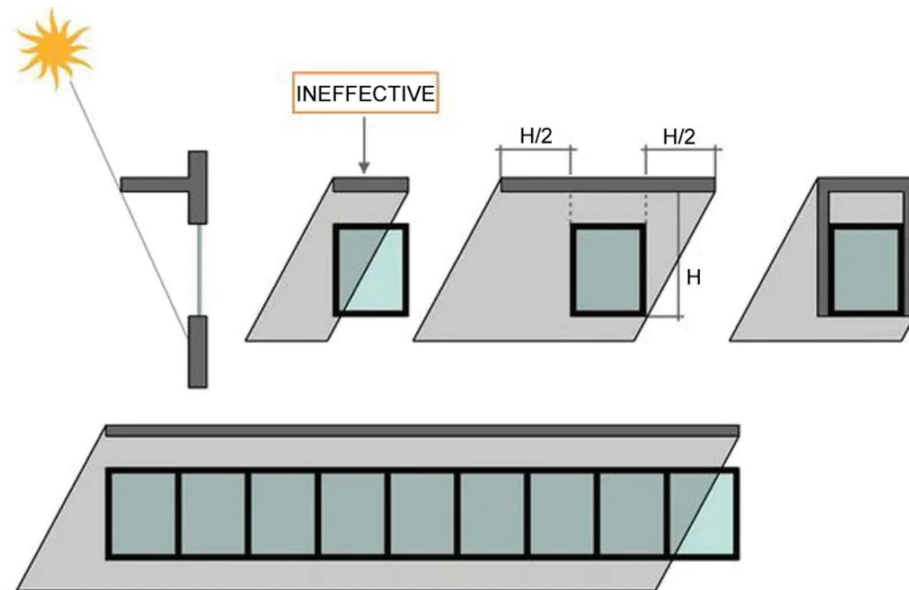

**Figure 5-5. Façade Design with External Shading**

The building envelope design should aim to achieve an Overall thermal transfer value (OTTV) of  $50 \text{ W/m}^2$  or less for external walls and  $25 \text{ W/m}^2$  or less for the roof.

#### 5.9.2.1 Fenestration Design and Glazing Selection

- i. When possible, choose a building form and fenestration design that minimize glazing while still meeting the building's aesthetic requirements.
- ii. Selecting the right glazing properties can help to lower the OTTV value, reduce cooling loads, and increase energy efficiency.
- iii. A suitable selection guide is to choose glazing with a low solar heat gain coefficient (SHGC) to decrease the amount of solar heat gain in the building, and high visible light transmission (VLT) to maximize daylight harvesting.



- iv. It is mandatory to choose a balanced selection because glazing with a low SHGC may result in an unsatisfactory VLT, such as glazing with a VLT of less than 10%, which can make the building appear dim. For instance, high-performance low-e double glazing can achieve a low SHGC of less than 0.15 with a VLT of 25% or higher.
- v. The ratio of light to solar gain (VLT to SHGC), also known as Light-to-solar gain (LSG), can be used as a guide. A higher LSG ratio is preferable for commercial buildings that utilize daylight harvesting.
  - a) Single glazing without low-e properties usually has LSG values between 0.5 to 1.0.
  - b) Single glazing with low-e properties typically has LSG values between 1.05 to 1.3.
  - c) High-performance double glazing with low-e properties generally has LSG values ranging from 1.5 to 2.0.

### 5.9.2.2 Building Materials

In temperate climate zone, using appropriate building materials with insulating properties can substantially decrease energy consumption. During the day, outdoor air temperature is usually high, whereas air-conditioned spaces are maintained at temperatures of 23°C to 27°C. As a result, heat is transferred from the outside to the inside of the building via conduction. However, during the night and early morning, the outdoor air temperature is likely to be lower than the indoor air temperature, causing heat flow to reverse compared to daytime conditions.

Table 5.4 illustrates the varying energy-saving potential of wall materials with different coefficients of heat transfer (U-values). The estimated values presented in the table are based on an energy simulation study outlined in report of Building Sector Energy Efficiency Project-2021 (BSEEP). The study's model was constructed using a square building without external shades, with a service core located in the building's center. The high, medium, and low night-time baseloads are associated with night baseloads of 50%, 35%, and 10% of the daytime peak load, respectively.

Table 5-4. Estimated Electricity Reduction for Wall Materials					
Case	Description	ASHRAE U-value (W/m <sup>2</sup> K)	Wall Simplified Energy Index (kWh/y per m <sup>2</sup> of wall area)		
			High nighttime baseload	Medium night-time baseload	Low night time baseload
1	Concrete wall, 100 mm	3.40	55	32	28
2	Brick wall, 115 mm	2.82	52	30	25
3	Brick wall, 220 mm	2.16	50	27	22
4	Double brick wall with 50 mm cavity, 300 mm	1.42	48	25	20
5	Autoclave lightweight concrete, 100 mm	1.25	47	24	18
6	Autoclave lightweight concrete, 150 mm	0.94	45	22	17
7	Autoclave lightweight concrete, 200 mm	0.75	45	22	16

*Source: Extracted from Public Works Department Malaysia-2021.*

### 5.9.2.3 Core Location

Placing the service core (which includes lift core, services, etc.) strategically in a building can serve as a buffer zone, mitigating the effects of solar radiation in air-conditioned spaces. Ideally, the core should face east or west. However, in some cases, other architectural considerations may limit the available options. In such cases, the designer should choose the next best alternative. The main goal of positioning the core is to optimize the effectiveness of the façade design in reducing solar heat gains.

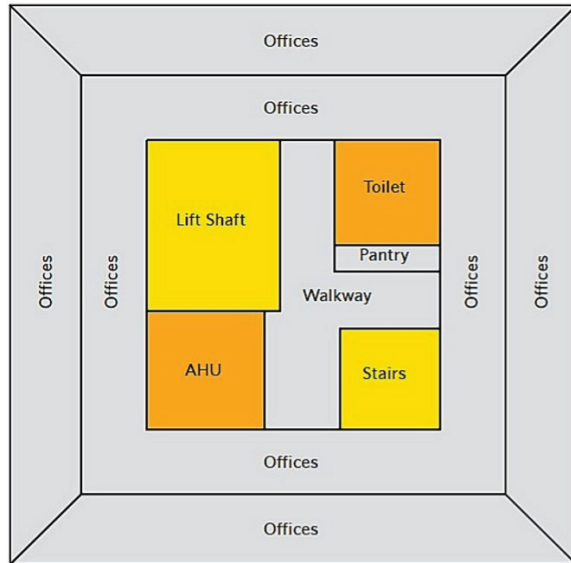

**Figure 5-6. Square Building Centre Core**

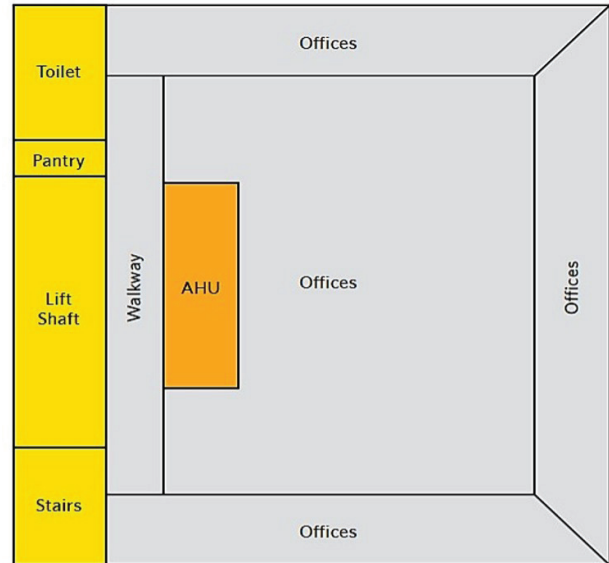

**Figure 5-7. Square Building Core West**

*Source: Public Works Department Malaysia-2021.*

By comparing Figures 5.6 and 5.7, it can be observed that a square building with a central core has a better view and larger glazing area, while a square building with a side core facing west has a smaller view and less glazing. However, in terms of solar heat gains, OTTV, and building energy performance (BEI value), the square building with a central core facing west has better performance (Figure 5.4).

### 5.9.3 Strategic Landscaping

This approach is well-suited for highly urbanized areas, where the surrounding buildings are densely packed with little greenery. Strategic landscaping within a building development can help mitigate heat gain. The aim of strategic landscaping is to create a cooler microclimate around the building and reduce the urban heat island effect. Highly urbanized and densely built-up areas tend to be considerably warmer than rural and less populated regions. Utilize as much available space around a building for landscaping (see Figure 5.8).

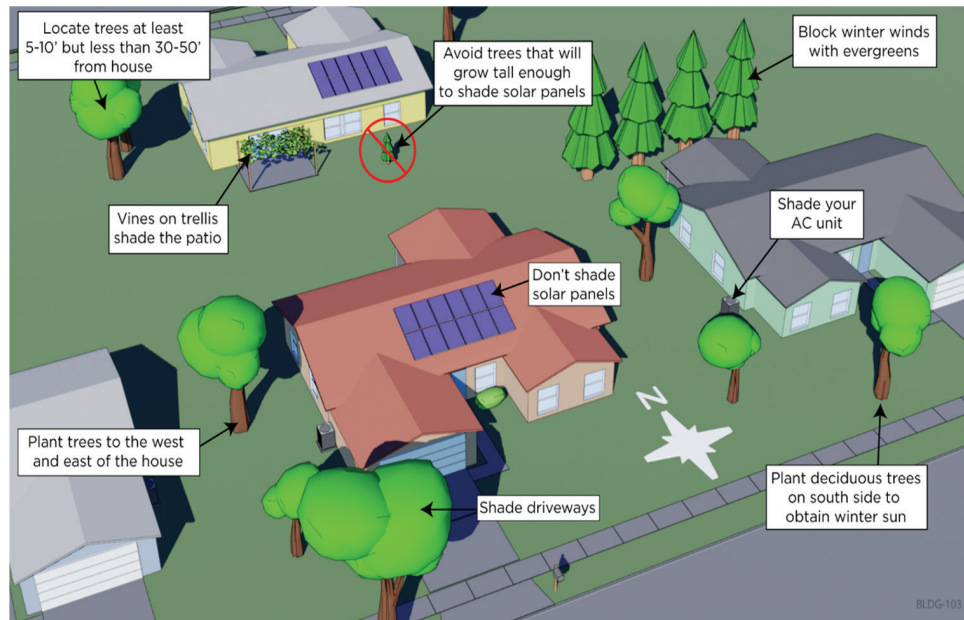

**Figure 5-8. Strategic Landscaping Designed to Establish a Cooler Microclimate**

(Source: *Building America Solution Centre-2023* <https://basc.pnnl.gov/>)

The selection of appropriate plant species and the use of high-reflectance materials in hardscape areas can help minimize the solar absorption of hard surfaces, thereby mitigating the urban heat island effect. Materials with a high solar reflectance index should be chosen. For instance, trees and shrubs near building facades that face east and west can offer external shading, reducing solar heat gain inside the building (refer to Figure 5.8).

#### 5.9.3.1 *Develop and Implement a Landscaping Plan*

Following are the develop and implement a landscaping plan to minimize heat gain in residential buildings;

1. Develop a site map indicating the current vegetation and the location of existing or planned buildings.
2. Design a landscaping plan that maximizes shading and evaporative effects, minimizes heat gain from hardscaping, and preserves solar access in the wintertime.
3. Ensure proper grading for drainage around the house and for water retention on the grounds.
4. Strategically plant or maintain landscaping around the home to provide shade for walls, windows, roof, skylights, hardscaping, and pavement.
5. Consider installing architectural structures such as pergolas and trellises to support strategic plantings.
6. Integrate water features where appropriate.

Use light-colored and permeable hardscaping and pavement materials.

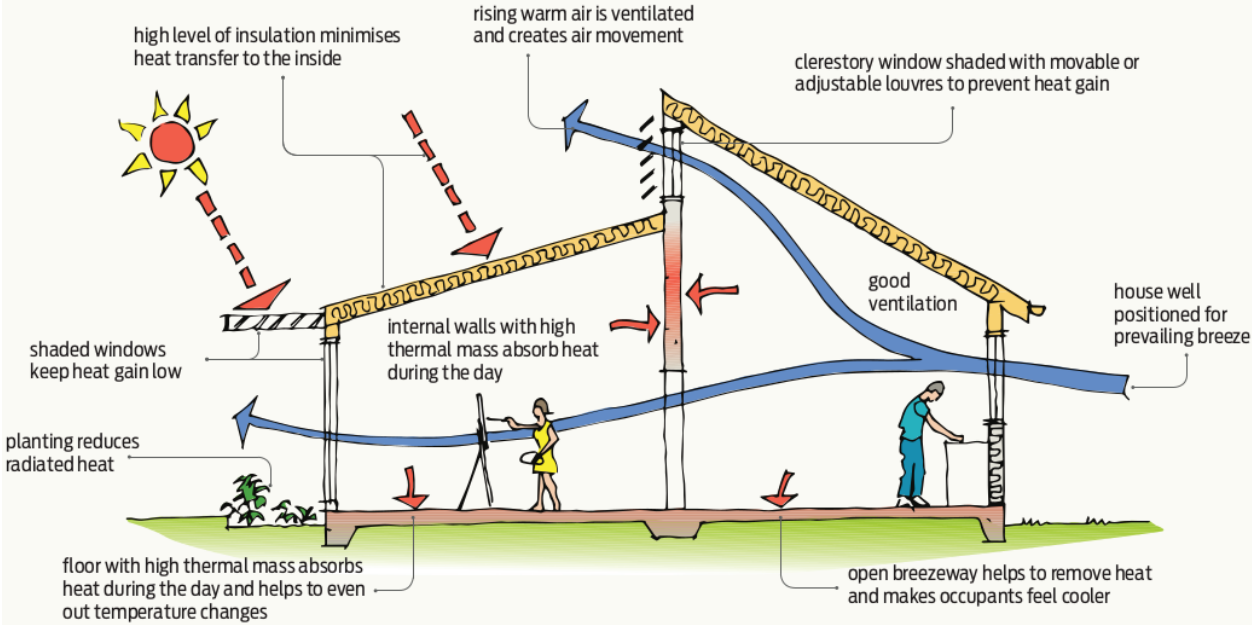

**Figure 5-9. Overall Passive Design Strategies**  
 (Source: Archi monarch -2023 <https://archi-monarch.com/>)



# 6

## RETROFITTING OF EXISTING BUILDINGS

The retrofitting section of the code emphasizes efficient administration and enforcement in transforming existing buildings into energy-efficient ones, outlining regulatory frameworks, financial incentives, and the importance of stakeholder engagement and dedicated project teams for successful implementation.

## CHAPTER NO 6

# RETROFITTING OF EXISTING BUILDINGS

---

## 6.1 INTRODUCTION

The retrofitting section of this code on Administration and Enforcement of retrofitting of existing buildings to convert them into energy-efficient buildings focuses on the steps and procedures required to ensure the successful implementation of retrofitting projects. The chapter emphasizes the need for proper administration and enforcement measures to ensure that retrofitting projects are completed effectively and efficiently. It provides guidelines on the regulatory framework, codes and standards, financial incentives, and procurement procedures that can be used to support the retrofitting process.

The chapter also highlights the importance of effective communication and stakeholder engagement in the retrofitting process. It recommends the establishment of a dedicated project team that can oversee the project and ensure compliance with all relevant regulations and standards. Overall, the chapter provides useful insights and guidance on the administrative and enforcement aspects of retrofitting existing buildings to make them energy-efficient. By following these guidelines, building owners and managers can ensure that their retrofitting projects are successful and contribute to a more sustainable future.

## 6.2 PURPOSE OF RETROFITTING

The purpose of the retrofitting section of this code is to provide minimum functional requirements for making the existing building structures energy-efficient through different Retrofitting Techniques.

## 6.3 SCOPE OF RETROFITTING

The retrofitting section of this code shall apply to independent housing units and low-rise buildings only.

## 6.4 APPLICABLE BUILDING SYSTEM

The provisions of the retrofitting section of this code shall apply to:

- a) Building envelopes

- b) Building mechanical systems and equipment, including heating, ventilation and air conditioning (HVAC) and general appliances.
- c) Water System (WS)
- d) Lighting
- e) Monitoring Devices

#### **6.4.1 Exemptions**

The retrofitting section of this code shall NOT apply to the following:

- Buildings that are older than 30 years.
- Government notified historically significant and heritage buildings.
- Low-Cost buildings for example small residential houses and mini markets in Villages.

### **6.5 SAFETY, HEALTH AND ENVIRONMENTAL CONSIDERATIONS**

The safety, health or environmental codes shall take precedence where this code is in conflict with safety, health, or environmental codes.

### **6.6 COMPLIANCE REQUIREMENTS**

Building Code serve as a guideline for AEC-professionals: Architects, Engineers and Consultants. Compliance of building codes is mandatory for user's security and making efficient building structures. Review and approval of building plans and specifications by respective sanctioning and development authorities / municipalities is mandatory to get the certification tag. The compliance requirement include:

- Implementation of recommended R-value for thermal performance in walls, floors, and roofs must be met as mentioned in sections of building envelope and building insulation of this code.
- According to the climatic zone of Pakistan, Passive techniques must be implemented as mentioned in the passive design section of this code.
- Installation of efficient heating, cooling and lighting systems to minimize electricity loads as mentioned in the HVAC and lighting sections of this code.
- Use of renewable energy systems should be encouraged in the retrofitting phase of the buildings as mentioned in the renewable energy section of this code.

### **6.7 MANDATORY REQUIREMENTS**

The building model ("Revit Model" in Building Information Modeling (BIM) tool) with energy modeling covering all aspects including building envelope, building insulation, heating/cooling zones along with the simulation results must be



submitted to the building control sections of concerned development authorities at the time of submission of the approval drawings. Energy Analysis BIM models before and after implementation of passive strategies/building energy the code should be submitted to the provincial development authorities in other provinces and to NEECA in Islamabad. The improvement should depict 50% increase in energy efficiency. During the construction phase, proper documentation in the form of photographs must be recorded properly.

## 6.8 BUILDING ENVELOPE

The design techniques mentioned in the building envelope section of this code for upgrading the building envelope shall aim at reducing heat transfer to and from the building.

### External Walls and Roof

External walls should have a minimum R Value of 13-15. Roof should have a minimum R Value of 30. Spray polyurethane foam (SPF) is a spray applied material that is widely used to insulate buildings and seal cracks and gaps, making the building more energy efficient and comfortable. More details are listed in building envelope section of this code, where structures are categorized according to their type, size and orientation.

### Glass and Shading Devices

The glazing shall be used very carefully, maintain a balance between natural light, ventilation and heat gain. The windows must be properly shaded and insulated to minimize the heat exchange. More details are listed in building envelope section of the code, where Glazing size and shading is discussed with reference to the orientation and classification of the structure.

## 6.9 AIR LEAKAGE/INFILTRATION

The building envelope shall be durably sealed, caulked, gasketed or weather stripped to minimize air leakages wherever the tendency exists. Vestibules/ lounges/entrances shall be provided to minimize infiltration through revolving/sliding/swinging doors. Air leakages for revolving/sliding/swinging entrance/exit doors shall not exceed 5.0 L/s/m<sup>2</sup> (1.0 cfm/ft<sup>2</sup>) and for windows, doors air leakage shall not exceed 2.0 L/s/m<sup>2</sup> (0.4 cfm/ft<sup>2</sup>).

## 6.10 BUILDING MECHANICAL SYSTEMS AND EQUIPMENT,

The building mechanical systems and equipment consist of the heating, ventilation and air conditioning (HVAC) and general appliances.

- A. Building mechanical and electrical system i.e., air conditioner, fridge, washing machines, fans etc. must be energy efficient (DC Inverters) and to be in compliance with the NEECA labeling regime.

- B. Power Intensive machinery like Air Conditioner should be switched off during peak hours. (Optimized Building Envelope can make it possible.)
- C. Temperature to be maintained as follows:
  - i. Summer: not less than 26° C
  - ii. Winter: not more than 20° C

## 6.11 RECOMMENDED VOLUNTARY ADOPTION

Natural Ventilation shall comply with the design guidelines as per ASHRAE standards 62.1-2022. Alternate energy refers to the use of renewable energy sources such as energy recovery systems, geothermal energy, solar systems, and other forms of sustainable energy. It is highly encouraged that these systems be adopted in buildings as an alternative to conventional heating, ventilating, and cooling systems.

Energy recovery systems are designed to capture and reuse energy that would otherwise be wasted, such as the heat generated by machinery or exhaust systems. These systems can significantly reduce energy consumption in buildings and are a great way to promote sustainability. Geothermal energy is another alternative energy source that can be used for heating and cooling buildings. This form of energy utilizes the natural heat generated by the earth's core, which is then transferred to buildings through a system of pipes and pumps. Geothermal energy is an incredibly efficient and sustainable energy source, with little to no carbon emissions. Solar systems are perhaps the most well-known form of renewable energy, and for good reason. They harness the power of the sun to generate electricity, which can be used to power buildings and other infrastructure. Solar energy is not only sustainable but also incredibly cost-effective in the long run. Overall, the adoption of alternate energy systems in buildings is crucial for reducing our dependence on fossil fuels and promoting sustainable living practices. By utilizing these systems, we can significantly reduce our carbon footprint and pave the way towards a cleaner and more sustainable future.

## 6.12 WATER SYSTEM (WS)

### 6.12.1 General

All service water heating equipment and systems shall comply with the mandatory provision of service water heating chapter of this code.

### 6.12.2 Mandatory Requirements

#### 6.12.2.1 Piping Insulation

The details of the piping insulation are mentioned in the Table 5.1 of chapter 5 of this code.

### 6.12.2.2 *Equipment Efficiency*

Service water heating equipment shall meet or exceed the minimum efficiency requirements presented in the Table 5.2 of chapter 5 of this code.

### 6.12.3 **Voluntary Adoption**

Building with a centralized system may have heat recovery units. The use of solar/ renewable energy for water heating is also recommended for adoption by the buildings with centralized and non-centralized systems. Residential facilities of 420 m<sup>2</sup> (4300 sq. ft) or greater plot area, commercial building, hotels and hospitals with centralized system may have solar / renewable energy for water heating at least one fifth of the design capacity.

### 6.12.4 **Compliance Documentation**

Compliance documents should include plans, drawings, specifications, and other relevant documentation that demonstrate compliance with the relevant building codes and regulations. These documents should be submitted to the relevant authorities for review and approval.

## 6.13 **LIGHTING**

Interior and exterior Lighting scheme should comply with lighting chapter of this code.

### 6.13.1 **Retro-Fitting Techniques for Energy Efficiency**

Recommendations to Achieve Energy Efficiency in Existing Structures. Existing structures has to be categorized with respect to their scale.

#### 6.13.1.1 *For Row Houses or Attached Houses*

The houses which are only open at front or back or both, 5 Marla and under houses are generally listed in this category. The side walls are attached to adjacent houses hence we can ignore them (as they are not exposed to Solar Radiation at all). Front and back walls need to be addressed in such houses. For Corner plots, it is mandatory to insulate front back and corner side of the building.

- i. Poly Urethane sprays or other Insulation sprays/ materials can be applied at front and back walls to increase their R, value ideally in the range of 13-15.
- ii. Similarly, roofs have to be insulated as well to achieve 30-R values.

The windows are only at front and back as well so we can treat them according to their orientation.

- i. If the house is open to east and west sides (East at front and back towards west or vice versa) then windows must have some vertical shading devices either some natural shading device like tress or some screen pattern (Jali) to save them from direct Exposure of Solar Radiation.

- ii. If the house is in South to North direction, then a horizontal shade of 21-24 inches is enough to block the direct sunlight. In such scenario the vertical shading devices are not required.
- iii. Apart from shading, windows should either be covered with Bubble Wraps or changed with Double Glazed windows (not recommended because it is uneconomical) to maintain interior temperatures.

#### **6.13.1.2 Semi Detached Houses**

The houses which have 3 sides open (5 Marla to 1 Kanal) are come under this category. In this category we have to deal with 3 open sides. All 3 sides have to be Insulated (13-15 R Value). Similarly roofs also need to be insulated (30-R Value). Window shades has to follow the same as discussed above, Horizontal shading devices on the South side and vertical shading devices towards the East and West Side (Double Glazed windows can be made mandatory to achieve higher efficiency).

#### **6.13.1.3 Detached Houses**

These houses are open from all sides, hence building envelope should be well insulated from all four sides. On all four sides, the envelop should have a 13-15 R value. The roof should have a R value of 30. The windows on all four sides should be properly shaded. Vertical or horizontal shading devices for windows should be used w.r.t orientation as discussed above. Windows must be double glazed. Double Heights, if any, should be equipped with clerestory windows to allow the hot air to escape and hence enhancing the ventilation. This category must be capable of producing their own energy through renewable means i.e., 10 Kw Solar Energy system.

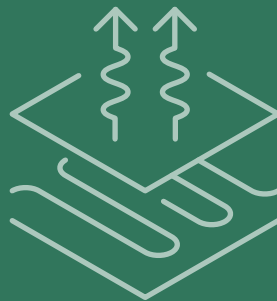

# 7

## BUILDING INSULATION

The building insulation chapter of ECBC 2023 sets guidelines for insulating buildings to improve energy efficiency, detailing minimum requirements for various components, methods to evaluate insulation effectiveness, and maintenance practices. It emphasizes the role of insulation in reducing energy consumption and carbon emissions, considering factors like air permeability and sustainable materials for overall energy efficiency and environmental sustainability.

## CHAPTER NO 7

# BUILDING INSULATION

---

## 7.1 INTRODUCTION

The building insulation chapter of the Energy Conservation Building Code 2023 provides guidelines for the insulation of building envelopes to improve energy efficiency and reduce heat gain/loss. The chapter outlines the minimum thermal insulation requirements for walls, roofs, floors, and windows, as well as the methods for determining the R-value (a measure of thermal resistance) of insulation materials. The chapter also covers the installation, testing, and maintenance of insulation systems. Additionally, it provides recommendations for the use of natural insulation materials and the reduction of thermal bridges (areas of the building envelope that allow for significant heat transfer). The ultimate goal of the chapter is to promote the use of insulation to reduce the energy consumption and associated carbon emissions of buildings.

The construction of a building requires careful consideration of its building envelope, which plays a crucial role in maintaining energy efficiency and ensuring occupant comfort. Apart from factors such as air and vapor permeability, insulation levels, resistance to unplanned air leakage, color, and thermal mass, there are several other factors that must be taken into account. Furthermore, the materials used in construction can impact resource efficiency and environmental sustainability. The construction of the building shell can also impact thermal comfort, as poorly insulated components can impact the radiant temperature of a space, even with the presence of heating and cooling systems. Additionally, the building envelope can contribute to acoustic comfort by reducing external noise from sources such as traffic.

## 7.2 HEAT TRANSFER THROUGH THE BUILDING ENVELOPE

The process of heat transfer through building envelopes is a complex and dynamic phenomenon, which is influenced by a variety of factors including solar gain, outdoor temperature, and indoor temperature. The performance of building envelopes is determined by four characteristics: thermal resistance (measured in terms of U-factor or R-value), air and vapor permeability, heat storage capacity (also known as thermal mass), and the condition and finish of the exterior surface.

### 7.3 U-FACTOR

The U-factor measures heat flow at a steady-state. In one hour, a temperature difference of 1°F between indoor and outdoor air moves a specific amount of heat through a 1 ft<sup>2</sup> surface area, measured in British thermal units (Btu). Heat can move from warmer to cooler regions in either direction. The majority of building materials and insulation have a uniform effect on the flow of heat in both directions. Nonetheless, specific building components, such as radiant barriers, can lower the amount of heat entering the structure, with little impact on the heat leaving the building.

For an adequate duration, the temperature continuity on both sides of a building element is assumed, allowing the heat leaving one side to be equal to the heat entering the other. Although U-factor is an oversimplified measure, it can provide an estimate of the average heat flow rates over time, making it a useful tool for illustrating building thermal performance. R-values and U-factors are fundamental terms in the field of building energy efficiency, as they are simple to comprehend and utilize. However, since temperatures fluctuate continuously in the real world, steady-state heat flow models may not always be entirely accurate.

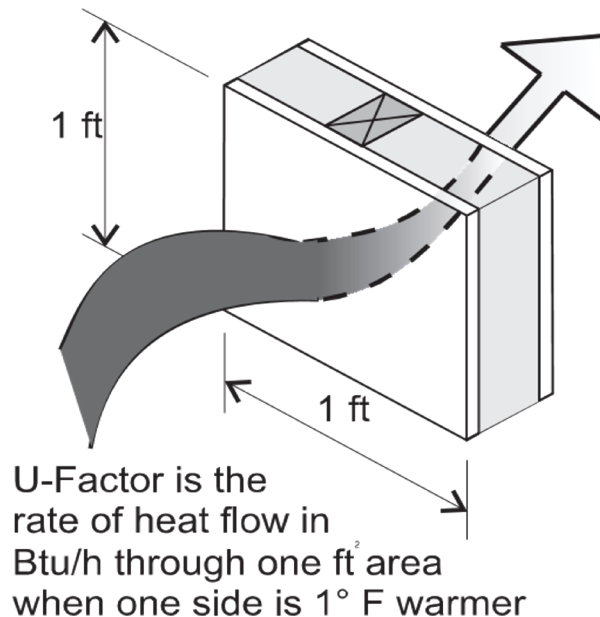

**Figure 7-1. Conceptual Representation of U-factor**

If metal framing is used in construction, a thermal bridge can significantly diminish the insulation effectiveness of the assembly. The U-factor considers all elements of the building assembly, which includes the conductance of the air layer present on both the inner and outer surfaces. The air film's conductance determines the rate at which heat transfers between the surface of the construction assembly and its surrounding environment. Several factors, such as the roughness

and orientation of the surface, as well as the wind speed across it, can affect the conductance of the air layer. While the U-factor can adequately describe heat transfer for light frame walls, it may not be as effective for heavy concrete and masonry walls, particularly under dynamic temperatures. The U-factor becomes less accurate in predicting heat flow through walls because concrete and masonry have different thermal properties.

#### **7.4 CONCEPT OF R-VALUE**

The R-values are also utilized to indicate constant-state heat flow, although they are expressed differently. Material R-values are proportionate to the thermal resistance of the material, signifying its ability to impede the flow of heat. A lower R-value indicates poorer thermal resistance, while a higher R-value indicates better insulation. Despite being commonly used in the construction industry, R-values alone cannot provide a comprehensive representation of an overall performance of assembly. For wall or roof assemblies, the R-value only reflects the thermal resistance of the insulation material and does not account for air leakage. Elements such as metal framing, steel beams, and metal window casements that penetrate the insulation can substantially diminish the efficiency of assembly.

Wood stud walls provide a suitable illustration, having insulated cavities and solid wood framing components within a single layer. Wood framing exhibits a lower R-value, allowing heat to conduct more easily compared to insulated regions. Therefore, when computing U-factors for walls, roofs, or floors, framing elements must be taken into account.

#### **7.5 THERMAL MASS**

Construction assemblies that possess higher thermal mass usually demonstrate superior thermal performance. Compared to lighter counterparts, heavy walls, roofs, and floors have greater thermal mass. Thermal mass can moderate and slow down the process of heat transfer, as demonstrated in Figure-7.2. The duration between the peak outdoor temperature and interior heat transfer can vary between 4 to 12 hours, depending on factors such as thickness, heat capacity, and other properties of the assembly. Delaying heat transfer can be as beneficial as reducing it, particularly for buildings that are not heated or cooled at night when outside air temperature decreases. In regions with humid climates, the diurnal temperature range on hot days is usually minor, so this effect is less significant than in arid areas, where the temperature swing can exceed 30°F.



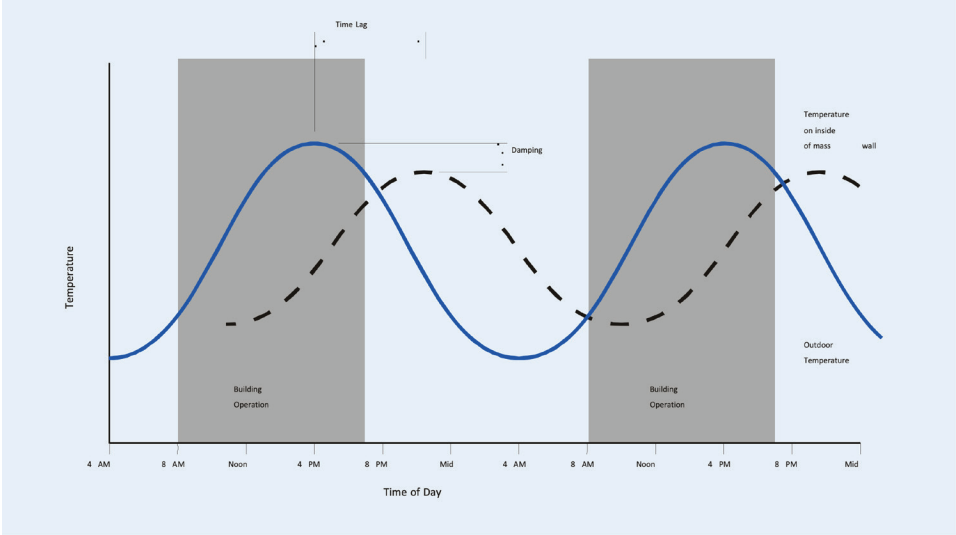

Figure 7-2. Temperature Swing

Providing interior air access to thermal mass can result in additional advantages. Enabling the cooling system to cool the thermal mass at night lowers the morning cooling load. During the daytime, the thermal mass inside a building heat up and emits heat at night when exposed to sunlight. This principle is of utmost importance in passive solar design for regions with cold and humid, cool and humid, or cool and dry climates. Figure 7.3 showcases a number of mass walls that are commonly employed in building construction.

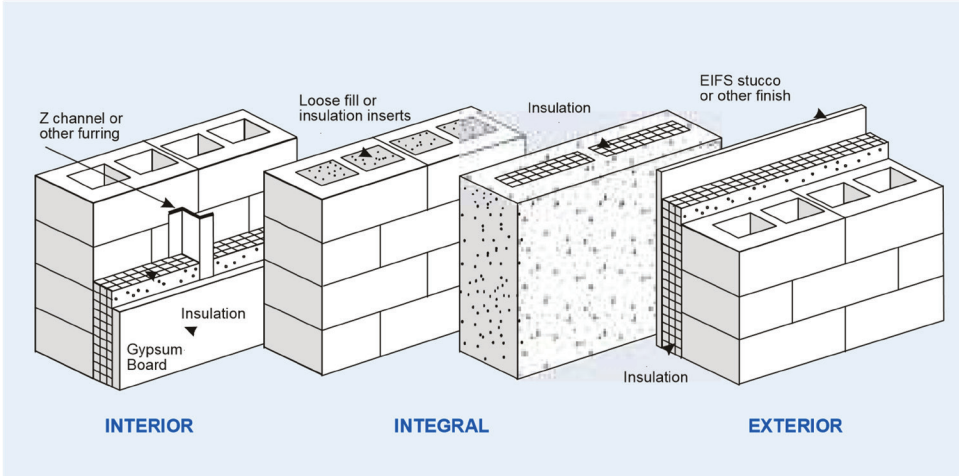

Figure 7-3. Construction of Mass Walls of Buildings

## 7.6 HEAT CAPACITY

Heat capacity (HC) is a parameter that indicates the amount of heat required to elevate the temperature of a building material by 1°F, expressed in Btu/ft<sup>2</sup>·°F. It serves as a measure of thermal mass, accounting for the heat capacity of each layer in a wall. HC can be approximated by multiplying the weight of a ft<sup>2</sup> of wall, roof, or floor by 0.2. For instance, a wall weighing 100 lb./ft<sup>2</sup> has an HC of approximately 20 Btu/ft<sup>2</sup>·°F. Energy efficiency standards such as ASHRAE/IESNA Standard 2019-90.1 utilize HC as a factor in the overall performance evaluation of building envelope components.

Mass wall construction represents a distinct category of construction that must adhere to specific thermal performance standards. While concrete is not an optimal insulating material, incorporating air bubbles through aerated concrete can enhance its insulation capability. Lightweight concrete can be created using low-density aggregates such as perlite or vermiculite. Additionally, moisture transport characteristics should be considered.

## 7.7 COOL ROOF SYSTEMS

The exterior surface significantly affects heat transfer, especially for roofs. Cool roofs have desirable surface characteristics, including high solar reflectance and high or normal emittance, which are two critical factors. High solar reflectance indicates that the roof surface reflects solar radiation rather than absorbing it, keeping the surface temperature low, reducing heat gain, and minimizing the need for air conditioning. Additionally, high or normal emittance is crucial as it enables a surface to release heat by radiating it back to the sky, thereby reducing cooling loads and extending the lifespan of roofing materials. In contrast, surfaces with low emittance, such as galvanized metal and other metallic finishes, struggle to release their heat by radiating it back to the sky. The advantages of cool roofs go beyond energy efficiency and can also alleviate the heat island effect in buildings, which is particularly important in densely populated urban areas.

### 7.7.1 Radiant Barrier in Buildings

When constructing a building, various factors must be taken into account, including the use of radiant barriers. In numerous building assemblies, a large cavity is present between the ceiling and roof, much like an attic. Radiant barriers are not typically utilized in walls but can be beneficial in reducing heat transfer from a warmer surface to a cooler one within cavities where radiation is the primary mode of heat transfer. A radiant barrier incorporates a metallic surface within the cavity that emits low levels of light. As a result, radiant barriers are often installed in attics.

## 7.7.2 Applicable Codes

Table 7.1 outlines the minimum R-values for prescriptive criteria, while Table 7.2 lists the maximum U-factors for component performance criteria. Exceeding the recommendations in the International Energy Conservation Code (IECC-2021) and ASHRAE Standard 2019-90.1 may be more cost-effective for most buildings than merely meeting them. For a comprehensive list of recommendations, please refer to the guidelines below in Table 7.1, to Table 7.4.

The presented table outlines the minimum R-value range for building components necessary to satisfy the prescriptive building envelope criteria specified in the International Energy Conservation Code (IECC-2021) and ASHRAE Standard 2019-90.1. The table is arranged into columns for each of the seven climate zones, each with representative cities, and rows for various construction classifications. The label «ci» denotes that the insulation should be installed continuously, without any breaks from framing members. Table 7.1 displays the same criteria as in the previous table but shows maximum U-factors instead of minimum R-values.

Table 7-1. Minimum Range of R-Values of Building Components							
<p>The presented table outlines the minimum R-value range for building components necessary to satisfy the prescriptive building envelope criteria specified in Standard 90.1. The table is arranged into columns for each of the seven climate zones, each with representative cities, and rows for various construction classifications. The label «ci» denotes that the insulation should be installed continuously, without any breaks from framing members. Table 7.1 displays the same criteria as in the previous table but shows maximum U-factors instead of minimum R-values. (from ASHRAE/IESNA Standard 2019-90.1)</p>							
Building Components	Climate Region						
	Hot and Dry	Hot and Humid	Temperate and Humid	Temperate Mixed	Cool and Humid	Cool and Dry	Cold and Humid
<b>Roofs</b>							
Insulation Entirely above Deck_	R-15 ci	R-15 ci	R-15 ci	R-15 ci	R-15 ci	R-15 ci	R-15 ci
Other Systems	R-30	R-30	R-30	R-30	R-30	R-30	R-38
<b>Walls, Above Grade</b>							
Mass_	NR	NR	R-5.7 ci	R-5.7 ci	R-7.6 ci	R-7.6 ci	R-9.5 ci
Steel Framed	R-13	R-13	R-13	R-13	R-3.8+13 ci	R-3.8+13 ci	R-3.8+13 ci
Wood Framed and Other	R-13	R-13	R-13	R-13	R-13	R-13	R-13
<b>Wall, Below Grade</b>							
Below Grade Wall	NR	NR	NR	NR	NR	NR	NR
<b>Floors</b>							
Mass_	R-4.2 ci	R-4.2 ci	R-6.3 ci	R-6.3 ci	R-8.3 ci	R-8.3 ci	R-8.3 ci
Steel Joist_	R-19	R-19	R-19	R-19	R-19	R-19	R-30
Wood Framed and Other	R-19	R-19	R-19	R-19	R-30	R-30	R-30
<b>Slab-On-Grade Floors_</b>							
Unheated	NR	NR	NR	NR	NR	NR	NR
Heated	R-12@7.5 in.	R-12@7.5 in.	R-12@7.5 in.	R-24@7.5 in.	R-36@10 in.	R-36@10 in.	R-36@10 in.

Table 7-2. Maximum Range U-Factors for Building Components							
<p>The maximum range of U-factors for building components, as specified by Standard 90.1, is outlined in the subsequent table. The delineates the criteria for each of the seven climate zones (with representative cities) in the columns, while the rows depict the criteria for different construction types. If insulation is required to be installed continuously, Table-7.2 illustrates the same criteria expressed as minimum R-values. (from ASHRAE/IESNA Standard 90.1-2019)</p>							
Building Components	Climate Region						
	Hot and Dry	Hot and Humid	Temperate and Humid	Temperate Mixed	Cool and Humid	Cool and Dry	Cold and Humid
<b>Roofs</b>							
Insulation Entirely above Deck_	R-15 ci	R-15 ci	R-15 ci	R-15 ci	R-15 ci	R-15 ci	R-15 ci
Other Systems	R-30	R-30	R-30	R-30	R-30	R-30	R-38
<b>Walls, Above Grade</b>							
Mass_	NR	NR	R-5.7 ci	R-5.7 ci	R-7.6 ci	R-7.6 ci	R-9.5 ci
Steel Framed	R-13	R-13	R-13	R-13	R-13+3.8 ci	R-13+3.8 ci	R-13+3.8 ci
Wood Framed and Other	R-13	R-13	R-13	R-13	R-13	R-13	R-13
<b>Wall, Below Grade</b>							
Below Grade Wall	NR	NR	NR	NR	NR	NR	NR
<b>Floors</b>							
Mass_	R-4.2 ci	R-4.2 ci	R-6.3 ci	R-6.3 ci	R-8.3 ci	R-8.3 ci	R-8.3 ci
Steel Joist_	R-19	R-19	R-19	R-19	R-19	R-19	R-30
Wood Framed & Other	R-19	R-19	R-19	R-19	R-30	R-30	R-30
<b>Slab-On-Grade Floors_</b>							
Unheated	NR	NR	NR	NR	NR	NR	NR
Heated	R-7.5@12 in.	R-7.5@12 in.	R-7.5@12 in.	R-7.5@24 in.	R-10@36 in.	R-10@36 in.	R-10@36 in.

The insulation levels recommended for buildings that are cost-effective go beyond the minimum requirements of ASHRAE Standard 2019-90.1, which are presented in Table 7.1 and Table 7.2. Table 7.3 and Table 7.4 display the recommended insulation levels that are considered to be more effective in terms of cost.

Table 7-3. Recommended Minimum Range of R-Value for Building Components							
<i>The table below exhibits the minimum R-value range required for different components of the building envelope. The designates each column to represent a climate zone (including representative cities), with various construction categories depicted in the rows. The term "CI" denotes the need for continuous installation without any obstructions by framing members. The recommendations in Table-7.3 are also provided in terms of maximum U-factors.</i>							
Building Components	Climate Region						
	Hot and Dry	Hot and Humid	Temperate and Humid	Temperate Mixed	Cool and Humid	Cool and Dry	Cold and Humid
<b>Roofs</b>							
Insulation Entirely above Deck_	R-20 ci	R-20 ci	R-20 ci	R-20 ci	R-20 ci	R-20 ci	R-20 ci
Other Systems	R-38	R-38	R-38	R-38	R-38	R-38	R-60
<b>Walls, Above Grade</b>							
Mass_	R-7.6 ci	R-7.6 ci	R-9.5 ci	R-11.4 ci	R-13.3 ci	R-13.3 ci	R-15.2 ci
Steel Framed	R-13+3.8 ci	R-13+3.8 ci	R-13+7.5 ci	R-13+7.5 ci	R-13+7.5 ci	R-13+7.5 ci R-13+7.5 ci	R-13+3.8 ci
Wood Framed and Other	R-13	R-13	R-13	R-13	R-13+7.5 ci	R-13+7.5 ci R-13+7.5 ci	R-13
<b>Wall, Below Grade</b>							
Below Grade Wall	NR	NR	NR	R-7.5 ci	R-7.5 ci	R-7.5 ci	R-7.5 ci
<b>Floors</b>							
Mass_	R-8.3 ci	R-8.3 ci	R-8.3 ci	R-10.4 ci	R-12.5 ci	R-12.5 ci	R-14.6 ci
Steel Joist_	R-30	R-30	R-30	R-30	R-30	R-30	R-38
Wood Framed and Other	R-30	R-30	R-30	R-30	R-30	R-30	R-30
<b>Slab-On-Grade Floors_</b>							
Unheated	NR	NR	NR	NR	R-10@24 in.	R-10@24 in.	R-15@24 in.
Heated	R-7.5@12 in.	R-7.5@12 in.	R-10@36 in.	R-10@36 in.	R-10	R-10	R-15

**Table 7-4. Recommended Range of Maximum U-Factors for Buildings Components**

*The subsequent table displays the recommended maximum ranges of U-factors for building envelope components. The columns present an overview of the each of the seven climate zones and corresponding representative cities. The rows showcase different construction types. To ensure continuous insulation, insulation should not be interrupted by framing members, which is denoted by the abbreviation CI. Table-7.4 also presents the same recommendations, but in the form of minimum R-values.*

Building Components	Climate Region						
	Hot and Dry	Hot and Humid	Temperate and Humid	Temperate Mixed	Cool and Humid	Cool and Dry	Cold and Humid
<b>Roofs</b>							
Insulation Entirely above Deck_	0.048	0.048	0.048	0.048	0.048	0.048	0.048
Other Systems	0.027	0.027	0.027	0.027	0.027	0.027	0.017
<b>Walls, Above Grade</b>							
Mass_	0.123	0.123	0.104	0.090	0.080	0.080	0.071
Steel Framed	0.084	0.084	0.064	0.064	0.064	0.064	0.064
Wood Framed and Other	0.089	0.089	0.089	0.089	0.051	0.051	0.051
<b>Wall, Below Grade</b>							
Below Grade Wall	C-1.140	C-1.140	C-1.140	C-0.119	C-0.119	C-0.119	C-0.119
<b>Floors</b>							
Mass_	0.087	0.087	0.087	0.074	0.064	0.064	0.057
Steel Joist_	0.038	0.038	0.038	0.038	0.038	0.038	0.032
Wood Framed and Other	0.033	0.033	0.033	0.033	0.033	0.033	0.033
<b>Slab-On-Grade Floors_</b>							
Unheated	F-0.730	F-0.730	F-0.730	F-0.730	F-0.540	F-0.540	F-0.520
Heated	F-1.020	F-1.020	F-0.840	F-0.840	F-0.550	F-0.550	F-0.440

Various calculation methods can be utilized to determine the thermal performance of construction assemblies, depending on their complexity and type. There are several ways to perform calculations.

1. The most straightforward way to determine the U-factor is through the series calculation method, which can only be used for constructions made of homogeneous materials.
2. For wood-framed assemblies, the parallel path calculation method is an extension of the series calculation method.
3. Effective R-value (Isothermal Planes): This method is appropriate for construction assemblies that use highly conductive materials in combination with insulated or hollow cavities, such as metal-framed walls/roofs and concrete masonry, as with the series and parallel path calculation methods.
4. Various calculation methods are available to determine a building's thermal performance. Depending on the construction's type and complexity, the appropriate method will be chosen. The Series Calculation Method is used for

homogeneous materials, the Parallel Path Calculation Method is used for wood-framed assemblies, and the Effective R-value (Isothermal Planes) method is used for constructions containing conductive materials and insulated or hollow cavities.

- Advanced mathematics and computer modeling can be used to accurately predict the U-factor of complex construction assemblies using two-dimensional calculation methods. For all construction types except slabs-on-grade, testing remains the most accurate method of determining the U-factor. Nonetheless, because testing can be time-consuming and expensive, calculation methods are frequently more cost-effective.

Table 7.5 Provides recommendations on the appropriate calculation method to use for different types of building assemblies

Table 7-5. Suitable Methods for Calculating U-Factors for Assemblies of Opaque Building					
Building Components	Series Calculation Method	Parallel Path Calculation Method	Effective R Value (Isothermal Planes)	Two-Dimensional Calculation Method	Testing
<b>Roofs</b>					
Insulation Entirely above Deck_	○			○	○
Wood Joists Systems		○		○	○
Steel Joists Systems			○	○	○
Other Systems				○	○
<b>Walls, Above Grade</b>					
Mass_			○	○	○
Wood Frame		○		○	○
Steel Frame			○	○	○
Other Frames				○	○
<b>Wall, Below Grade</b>					
Mass Walls			○	○	○
Other Components				○	○
<b>Floors</b>					
Mass Flooring	○		○	○	○
Steel Joist_			○	○	○
Wood Framed		○	○	○	○
Other Frames				○	○

### **7.7.3 Computer Aided Program for Calculating U-factors for Assemblies of Opaque Building**

Different design tools and computer programs can be used to implement the above-mentioned calculation methods. The following tools and programs are among them:

A two-dimensional heat transfer analysis can be performed using Therm-program, which is designed for analyzing window frames. Download the program from the following link [http://windows.lbl.gov/software/therm/therm\\_getacopy.htm](http://windows.lbl.gov/software/therm/therm_getacopy.htm).

### **7.7.4 Pre-calculated Values for Buildings**

For common building constructions, U-factor values have been calculated and published in various sources. The ASHRAE/IESNA Standard 90.1-2019, Appendix A, contains published measurements for walls, roofs, floors, slabs, and below-grade walls in both inch-pound and metric (SI) units.

## **7.8 INDOOR AIR QUALITY AND MOISTURE**

To prevent moisture from infiltrating construction cavities, it is essential to have an exterior weather barrier with a drainage plane. A proper drainage and drying system must also be incorporated into the wall, roof, and foundation systems to prevent water entry. Damp or wet cavities, attics, and plenums can cause mold and poor indoor air quality (IAQ). In addition to damaging the structure and negatively impacting insulation performance, moisture can also increase energy and operating costs. Mold growth in wall systems, attics, and foundation spaces, such as crawl spaces or utility trenches, can often cause IAQ complaints.

Moisture can also migrate into construction cavities due to the movement of water vapor from the warm and humid side of an assembly to the cold and dry side. When it cools and reaches dew point conditions, vapor can condense into water molecules, causing damage and mold growth. Moisture migration can also be caused by air leaks. In non-humid climates, a vapor barrier should be installed on the hot, moist side of framed walls, floors, and roofs, and on the exterior side in humid climates. Materials such as asphalt-impregnated paper or metal foil are commonly used as vapor barriers in insulation products. During construction, it is crucial to install vapor barriers continuously, securely attach them to framing members, and avoid damaging them. Areas with high humidity, such as locker rooms and food preparation areas, require special attention.

Proper ventilation, in addition to the installation of vapor retarders, is critical for drying spaces where moisture can accumulate. Attics and crawl spaces must be ventilated, and vaulted ceilings must be ventilated with a minimum of one inch of airspace above insulation. Even wall cavities may need to be ventilated in extreme climates. Ventilated gravel should be used as an infiltration barrier under slabs with soil gas contaminants such as radon or methane.

### **7.8.1 Air Infiltration**

Effective infiltration control is essential for achieving energy-efficient buildings. Air leaks allow outside air to enter conditioned and semi-heated spaces,



adding to the sensible heat and, in humid conditions, the latent heat load. Removing latent heat through air conditioning systems can be costly. The installation of air barriers in walls and roofs is mandatory to prevent air leakage. These barriers should not only be durable and easy to maintain but should also be able to withstand both positive and negative pressures and transfer loads. The substrate must be permanent or sandwiched between gypsum sheathing and rigid insulation. The air barrier is continuous throughout all envelope parts, including foundations, roof, and all control, construction, and expansion joints.

### **7.8.2 Insulation Protection**

To ensure the effectiveness of insulation, it is crucial to protect it from various sources of damage such as sunlight, moisture, landscaping equipment, and wind. To protect rigid insulation installed along the perimeter of the slab from damage caused by gardening or landscaping equipment, it should be covered. In addition, a waterproof membrane or exterior finish is required to protect rigid insulation used on walls and roofs. Typically, a drainage plane is necessary for exterior insulation finish systems (EFIS) to allow wind-driven rain to escape behind the insulation.

In cold climates, it is best to avoid installing mechanical equipment in attics as it generates heat, leading to uneven snow melting and ice dams. However, in moderate climates, access to equipment in attic spaces can be achieved without compressing or damaging the insulation, by using walking boards, access panels, and other techniques.

Fiberglass insulation in exposed areas, such as return air plenums, must be encapsulated to prevent fibers from becoming airborne. To maintain a continuous vapor barrier, all seams should be sealed with tape or mastic. To serve this purpose, insulation must be stapled in place, not simply left hanging.

### **7.8.3 Environmental Considerations and Efficiency of Material**

One of the most effective ways to promote material efficiency in buildings is by reusing all or part of an existing building envelope. This reduces solid waste generation during construction and decreases the environmental impact associated with producing and transporting materials for a new building envelope. However, if the existing building structure cannot be upgraded to meet high-performance standards, reusing the building envelope may not be feasible.

To make a building envelope more material efficient, panelized, pre-cut, and engineered construction products can be used, and standard dimensions can be incorporated in the design to reduce on-site waste. Planning for future adaptability and selecting durable materials and systems can also contribute to material efficiency. In addition, there are building envelopes and insulation materials that are recyclable, contain recycled materials, or are environmentally friendly. These products use materials that do not introduce toxins into the building or natural environment, and they may be produced in an eco-friendly manner.

## 7.9 RECOMMENDATION FOR WALL INSULATION

The R-13 is the minimum recommended cavity insulation for wood-framed walls, irrespective of climate. Furthermore, in climates with cool and humid conditions, cold and humid conditions, and cool and dry conditions, R-7.5 insulating sheathing should be installed. Please refer to the table below for the equivalent U-factor recommendations. All climates recommend R-13 cavity insulation for metal-framed walls.

- a. For hot and humid climates and hot and dry climates, continuous insulating sheathing of R-3.8 is recommended. In other climates, continuous insulating sheathing of R-7.5 is recommended.
- b. For hot and dry as well as hot and humid climates, it is recommended to use continuous R-7.6 insulation for mass walls. In temperate and humid climates, it is advisable to upgrade to R-9.5, whereas in cool and humid climates, R-13.3 insulation is recommended.
- c. For cold and humid climates, the recommended insulation level is R-15.2. Depending on the local climate, higher insulation levels may be necessary.

### 7.9.1 Description

It is important to consider the construction of exterior walls in terms of comfort, operating costs, and acoustic separation, as well as the size of the heating and cooling systems required. The construction type, whether wood-framed, steel-framed, or mass construction, is typically determined by factors such as the size and height of the building, budget constraints, fire separation requirements, and durability requirements.

Each climate region and class are presented separately, with recommended insulation levels based on a life-cycle cost analysis. In colder climates, more insulation is needed, while in temperate climates, less insulation may be required.

### 7.9.2 Integrated Design Implications

Properly insulated and sealed walls can effectively reduce moisture intrusion caused by wind-driven rain, cold drafts, and thermal loads in buildings. This can result in lower HVAC equipment requirements and cost savings.

### 7.9.3 Design Details

In cold climates, it is recommended to install a continuous vapor barrier on the inside surface of framed walls. However, in hot and humid climates and air-conditioned buildings, vapor barriers should be installed on the exterior of the buildings. When using paper or foil vapor barriers provided with batt insulation, they should be stapled to the face of the studs instead of the inside to provide a more secure and continuous vapor barrier while reducing insulation compression.

The air barrier should be continuous and durable, with details on how it is connected to the foundation, windows, doors, different wall systems, roof, and utility penetrations. Wood framing with a stud spacing of 24 inches should be used for wood framing in hot and dry climates, cool and humid climates, and cool and dry

climates, with 2x6 framing preferred. Minimum wood framing and rigid insulation over headers over doors and windows should be used at corners, intersections, and openings.

To minimize thermal bridges and infiltration, electrical and mechanical equipment should be minimized for exterior walls. The back of exterior wall outlet boxes should be sealed both to the gypsum wallboard and around wires if insulation is used in stud cavities. Outlets are commonly located on the interior walls and wings of buildings.

## **7.10 ROOF INSULATION**

### **7.10.1 Recommendations for Roof Insulation**

To ensure adequate insulation, it is recommended to install R-20 insulation completely above the structural deck. The thickness of the insulation will vary depending on the type of insulation used. In all climates except cold and humid, R-38 insulation should be installed in attics and other constructions, while R-60 insulation should be installed in cold and humid climates.

### **7.10.2 Description**

The construction of roof assemblies can impact the size of heating and cooling systems in addition to comfort, operating costs, and acoustic separation. The size, height, fire separation requirements, durability, and other factors typically determine the construction class of a building (wood-framed, steel-framed, or mass). Based on a lifecycle cost analysis, different insulation levels are recommended for each climate region and class. Insulation is generally more critical in colder climates, while it is less critical in more temperate climates. Roofs and other components of the building envelope require a review of the concepts of thermal heat transfer discussed in the Overview section of this chapter.

### **7.10.3 Design Details**

When insulating the ceiling of a sloped roofed attic, it is important to have full depth insulation all the way to the edge. Raised heel trusses may be required for this type of construction. A constant temperature should be maintained across the roof in addition to providing a continuous and effective thermal barrier. If insulation is thinner near the edge, snow can melt and refreeze as an ice dam, causing water leakage and structural damage if it melts and refreezes.

1. Attics should not be used to house heat-producing equipment such as furnaces, water heaters, or air handlers, as they can cause uneven roof temperatures and lead to ice dams.
2. Insulation should not be installed in exposed applications or in return air plenums unless it is enclosed or sealed to prevent contact with moving air. Leaving it exposed is always a bad idea. In addition, ensure that insulation is dry before enclosing walls or other cavities to prevent moisture buildup.

3. Insulation should not be installed over suspended ceilings as it can be easily disturbed by maintenance workers and does not act as an effective barrier to infiltration. Building codes may require ventilation to the exterior if insulation is located at the ceiling. Type IC light fixtures should be used to light insulated gypsum board ceilings.
4. Consider using recycled insulation materials, such as cellulose made from recycled paper, in attics and other areas where loose-fill insulation is used. The fire retardant used in cellulose insulation should not contain VOCs and should be non-polluting.

#### **7.10.4 Operation and Maintenance Issues**

Regular maintenance of the roof membrane is crucial to prevent moisture from seeping in. Moisture can cause mildew to grow on ceilings and roofs, resulting in significant indoor air quality problems. Materials used for insulation do not require maintenance. The roof drainage system must also be maintained regularly, especially for low-pitched roofs.

### **7.11 COOL ROOFS**

#### **7.11.1 Description**

Roof surfaces absorb a lot of heat from solar radiation, but using materials with high reflectance and emittance can significantly reduce this load. Materials with high reflectance prevent sunlight from being absorbed, while those with high emittance emit radiation into the sky. Cool roofs, which are typically white in color and smooth in texture, are a popular option for reducing heat gain. Single-ply roofs and liquid-applied roofs are two types of cool roof products available. White PVC, CPE, CPSE, and TPO are among the most effective single-ply roofing products. Asphalt cap sheets, modified bitumen, and other substrates can be coated with liquid-applied products, such as white elastomeric, polyurethane, and acrylic coatings. Additionally, cool roofs are now available in a variety of colors.

1. White PVC (polyvinyl chloride)
2. White CPE (chlorinated polyethylene)
3. White CPSE (chlorosulfonated polyethylene, e.g. Hypalon)
4. White TPO (thermoplastic polyolefin).
5. Liquid-applied products may be used to coat asphalt cap sheets, modified bitumen, and other substrates. Products include:
  6. White elastomeric coatings
  7. White polyurethane coatings
  8. White acrylic coatings
  9. White paint (on metal or concrete)
10. Cool roofs are becoming available in different colors.

Table 7.7 lists several common roofing products and their reflectance and emittance values.

**Table 7-6. Solar Reflectance and Emittance Values for Various Roofing Materials**

<b>Description</b>	<b>Material</b>	<b>Reflectance</b>	<b>Emittance</b>
Reflective Coatings	Elastomeric coating over asphalt shingle	0.71	0.91
	Aged elastomeric on plywood	0.73	0.86
	Elastomeric coating on shingle	0.65	0.89
	Aluminum pigmented roof coating	0.30 - 0.55	0.42 - 0.67
	Lo-mit on asphalt shingle	0.54	0.42
White Metal Roofing	Siliconized white	0.59	0.85
Single-Ply Roof Membrane	Black EPDM	0.06	0.86
	Grey EPDM	0.23	0.87
	White EPDM	0.69	0.87
	White T-EPDM	0.81	0.92
Paint	White	0.85	0.96
	Aluminum paint	0.80	0.40
Asphalt Shingles	Black	0.03 - 0.05	0.91
	Dark brown	0.08 - 0.10	0.91
	Medium brown	0.12	0.91
	Light brown	0.19 - 0.20	0.91
	Green	0.16 - 0.19	0.91
	Grey	0.08 - 0.12	0.91
	Light grey	0.18 - 0.22	0.91
	White	0.21 - 0.31	0.91
Note: Products with shading have a reflectivity greater than 0.70 and emittance greater than 0.80.			

The advantages of cool roofs may be somewhat limited in regions that are cool and humid or cold and humid (Koppen Classification). However, cool roofs can be employed in all areas of buildings and climates. As part of the schematic design process, cool roofs should be considered to maximize the benefits of downsizing equipment.

### **7.11.2 Integrated Design Implications**

Cool roofs can significantly reduce cooling loads, which can lead to downsizing of air conditioning equipment or even replacement of air conditioning with natural ventilation in some cases. When designing the roof, all roofing systems, including skylights, roof penetrations, and rooftop equipment mounts, must be considered. It is important to protect roof membranes from excessive wear and damage caused by equipment access.

### **7.11.3 Design Tools**

Assessing the effectiveness of cool roofs can be quite challenging, as many factors contribute to their performance. One reason is that cool roofs reflect sunlight, which requires a model that considers the location and intensity of the sun. If the roof absorbs the sun's energy instead of reflecting it, the surface temperature of the roof increases, exacerbating the temperature differences. Moreover, when the roof surface temperature is hot, it radiates heat to the cool night sky, providing an important benefit that relies on knowing the temperature of the roof surface and the night sky. To accurately evaluate the benefits of cool roofs, energy simulation programs are necessary, given the intricate heat transfer involved. It is crucial to customize these programs according to the building's intended use to ensure that the energy savings are accurately reflected.

### **7.11.4 Design Details**

To maintain the efficacy of a cool roof, it is important to prevent the accumulation of dirt on its surface. A slope of at least 0.25 inches/foot is recommended for roof surfaces to minimize dirt buildup. It is also crucial to choose liquid-applied coatings that are compatible with the underlying substrate when using them. To meet the ASTM Standard 6083-2021 for durability and elongation, a minimum thickness of 20 mils is required for liquid-applied cool roof coatings.

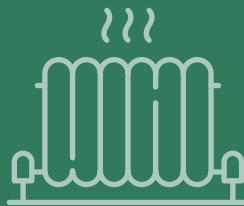

# 8

## HEATING, VENTILATION, AND AIR CONDITIONING

The HVAC chapter of the Energy Conservation Building Code 2023 establishes minimum energy efficiency requirements for HVAC systems in buildings, covering equipment selection, installation, operation, and maintenance, as well as ductwork, piping, insulation, and controls. It aims to optimize energy efficiency and conservation, ensuring HVAC systems operate efficiently without compromising indoor environmental quality and occupant comfort. Adherence to these standards is crucial for reducing energy consumption and minimizing waste in HVAC operations.

## CHAPTER NO 8

# HEATING, VENTILATION, AND AIR CONDITIONING

---

## 8.1 INTRODUCTION

The Heating, Ventilation, and Air Conditioning (HVAC) chapter of the Energy Conservation Building Code 2023 provides minimum energy efficiency requirements for HVAC systems in buildings. The chapter covers a range of topics related to HVAC systems, including equipment and system selection, installation, operation, and maintenance. It also includes provisions for ductwork, piping, and insulation, as well as requirements for HVAC controls and monitoring systems. The chapter aims to ensure that HVAC systems are designed, installed, and operated in an energy-efficient manner, while also providing adequate ventilation and maintaining indoor air quality.

All heating, ventilating, and air-conditioning systems installed in buildings shall adhere to the mandatory provisions specified in this section of the Energy Conservation Building Code 2023. This section sets the minimum requirements for HVAC systems, including equipment and controls, to ensure optimal energy efficiency and conservation. The provisions in this section are designed to reduce the energy consumption of HVAC systems without compromising the indoor environmental quality and thermal comfort of occupants. Adherence to these provisions is necessary to ensure the efficient operation of HVAC systems and to minimize energy waste.

## 8.2 MANDATORY REQUIREMENTS FOR HVAC

All Heating, ventilating, and air-conditioning systems falling under the subject criteria designed and installed shall comply with the mandatory provisions of this Chapter.



### 8.3 HVAC DESIGN

Heating, Ventilation, and Air Conditioning (HVAC) systems are critical components of a building's energy consumption, accounting for approximately 30-40% of the total energy consumed in centrally air-conditioned buildings. Therefore, it is essential to design and install energy-efficient and sustainable HVAC systems that comply with the mandatory provisions of the Energy Conservation Building Code 2023. The design consultant plays a critical role in ensuring that the code is followed and all energy-efficient techniques are applied to the HVAC system to minimize energy consumption and reduce the building's carbon footprint. By implementing the code's guidelines, building owners and occupants can benefit from improved indoor air quality, greater thermal comfort, and lower energy bills. Therefore, compliance with the mandatory provisions of this section is necessary to achieve energy efficiency and sustainability in building design and construction.

### 8.4 ENVIRONMENTAL CONDITIONS

#### 8.4.1 Climatic Conditions

Pakistan has diverse weather conditions and different climatic zones, which means that the outdoor design conditions should be tailored to the specific city. To conserve energy, the maximum ambient design criteria for Load Calculations/ HVAC system design and Equipment selection purposes in the geographic areas listed in the following table should be the 2.0% exceedance temperature values provided. In case any city is not mentioned in the table, consultation with the Pakistan Meteorological Department is necessary. The table 8-1 below shows weather and climate data for different cities in Pakistan. It is crucial to consider these factors while designing and installing HVAC systems to ensure energy efficiency and sustainability. Therefore, design consultants play a critical role in following the Energy Conservation Building Code and applying all energy-efficient techniques to HVAC systems.

**Table 8-1. Weather and Climate Data of Major Cities**

City	Station (City)	Lat.	Long.	Elev.	Heating DB		Cooling DB/MCWB						Evaporation WB/MCDB				Dehumidification DP/HR/MCDB						Extreme Annual WS	Heating/Cooling Degree Days		
					99.6%	99%	0.4%		1%		2%		0.4%		1%		0.4%			1%				HDD	CDD 65	
							DB	MCWB	DB	MCWB	DB	MCWB	WB	MCDB	WB	MCDB	DP	HR	MCDB	DP	HR	MCDB				1%
Hyderabad	25.38N	71.80E	1864	5632	471	2388	1022	4261	1564	4741	5896	3771	1103	103	29.0	32.8	29.0	103	17.3	12.1	780	780	4741	5896	3771	
Chitral	35.88N	71.80E	1864	5632	471	2388	1022	4261	1564	4741	5896	3771	1103	103	29.0	32.8	29.0	103	17.3	12.1	780	780	4741	5896	3771	
Multan	30.20N	71.42E	400	401	427	111.3	82.4	62.0	79.7	62.6	77.4	76.4	84.4	97.8	83.7	97.2	81.5	81.5	166.0	166.0	91.3	80.7	161.6	161.6	91.3	80.7
Muree	33.91N	73.38E	6978	28.5	30.3	82.4	62.0	79.7	62.6	77.4	76.4	84.4	97.8	83.7	97.2	81.5	81.5	166.0	166.0	91.3	80.7	161.6	161.6	91.3	80.7	
Quetta	30.25N	66.94E	5250	22.7	25.4	99.6	67.6	97.9	67.0	96.1	66.2	72.3	93.4	70.6	91.9	65.9	65.9	142.2	142.2	73.0	68.7	137.4	137.4	72.2	68.7	
Peshawar	34.01N	71.58E	1181	37.8	40.1	107.2	74.5	104.1	75.8	101.8	76.8	85.1	96.9	83.7	95.6	82.4	82.4	176.6	176.6	94.0	81.7	144.0	144.0	91.9	81.7	
Abbottabad	34.18N	73.25E	4295	30.9	32.8	93.4	68.5	90.9	69.0	88.4	69.4	76.3	84.8	75.3	83.6	74.0	74.0	149.1	149.1	81.7	73.0	144.0	144.0	80.7	80.7	
Lahore Allama Iqbal	31.52N	74.40E	712	37.8	40.8	109.7	74.0	107.4	73.9	104.2	73.9	84.4	94.2	83.5	92.9	82.4	82.4	173.7	173.7	90.0	81.0	165.1	165.1	88.9	88.9	
Karachi Jinnah Intl	24.91N	67.16E	100	50.4	53.4	102.2	72.8	98.9	73.5	96.9	74.3	82.8	92.1	82.0	91.1	80.8	80.8	160.8	160.8	88.0	80.1	156.7	156.7	87.6	87.6	
Islamabad Intl	33.62N	73.10E	1168	36.2	38.4	105.9	73.1	102.6	73.4	100.4	73.0	82.5	93.8	81.5	92.5	79.7	79.7	164.2	164.2	88.6	78.9	159.5	159.5	88.1	88.1	

Source: <http://ashrae-meteo.info/v2.0/places.php?continent=Asia>

**Meaning of acronyms:***DB: Dry-bulb temperature, °F**WB: Wet bulb temperature, °F**MCWB: Mean coincident wet bulb temperature, °F**Long: Longitude, °**Elev: Elevation, ft**HR: Humidity ratio, grains of moisture per lb of dry air**WS: Wind speed, mph**HDD and CDD 65: Annual heating and cooling degree- days, base 65 °F, °F-day**Lat: Latitude, °**DP: Dew point temperature, °F**MCDB: Mean coincident dry bulb temperature, °F***8.4.2 Cooling Load Calculation for HVAC Systems**

The cooling load is calculated using the Summer Design Dry Bulb temperature and the Mean Coincident Wet Bulb temperature. These temperatures are used to determine the supply air requirements for the HVAC system. On the other hand, the heating load is designed at the winter Dry Bulb temperature. Essentially, this means that the HVAC system is designed to provide the necessary cooling or heating capacity based on the expected temperature conditions during the summer and winter seasons. This ensures that the HVAC system operates efficiently and effectively, while also meeting the energy efficiency requirements of the Energy Conservation Building Code 2023.

For a building located in coastal areas, the appropriate capacity of the HVAC system can be determined by calculating the cooling load at both the Design Wet Bulb and coincident Dry Bulb temperatures. This will determine which set of conditions results in a larger HVAC system capacity.

**8.4.3 Technology Applications for Hotter Climate Zones**

For hotter climate zones, this section suggests using air-cooled packaged units, air-cooled condensers, and air-cooled chillers for such zones. It specifies that the selection of these systems should be based on the Summer Design Dry Bulb temperature at 1% exceedance. In other words, the cooling systems should be designed to handle extreme temperatures that may occur with a frequency of 1% or less during summer in hotter climate zones. This requirement is important to ensure that the HVAC system is efficient and can adequately cool the building during the hottest months of the year.

**8.4.4 Natural Ventilation**

As energy costs and environmental concerns continue to rise, natural ventilation has emerged as a viable option for reducing energy consumption and costs while maintaining a healthy, comfortable and productive indoor environment. Design consultants should consider incorporating natural ventilation strategies into their designs. Guidelines for ventilation rates and indoor air quality are provided by ASHRAE Standard 62.1.

## 8.5 INDOOR DESIGN CONDITION

1. Table 8.2 contains the minimum indoor conditions to be used for the design of HVAC systems in various facilities.
2. Design conditions for occupancies other than those listed in Table 8.2 shall comply with the recommendations of the ASHRAE Handbooks; ASHRAE STD 55.
3. HVAC systems shall be capable of maintaining dry bulb temperature and relative humidity (if applicable) within the performance range given in Table 8.2.

Table 8-2. Inside Design Conditions				
Facility	DB	Percent Relative Humidity	Tolerance	
			Air Motion m/s (fps)	DB °C (°F) (% RH)
Offices, schools, theaters	75)24)	%50	0.25-0.075 (0.82-0.25)	±2(±3.6) ±%20
Shops, houses, apartments, trailers, dining halls and stores	75)24)	%50	0.25-0.075 (0.82-0.25)	±2(±3.6) ±%20
Computer rooms, control rooms, communication facilities, process, interface buildings, analyzer houses	72)22)	%50	0.25-0.075 (0.82-0.25)	±2(±3.6) ±%20
Unattended equipment rooms (excluding communication rooms)	85)29) (Unless otherwise required by equipment manufacturers)			±2(±3.6) ±%10
Unattended electrical substations	95)35)	-	-	-
Hospitals and clinics (various rooms)	Refer to ASHRAE Applications Handbook & JCIA			
Laboratories	Refer to ASHRAE Applications Handbook			

## 8.6 HVAC LOAD, DESIGN CALCULATIONS

Design load calculations are the basis of energy efficiency; these shall be done using appropriate software. All energy conservation elements techniques shall be applied to make the project not only energy efficient, sustainable but to provide comfort as required. Design consultant shall prepare an energy consumption model for both Electrical & thermal.

## 8.7 SYSTEM DESIGN

1. HVAC system can be designed in many ways. Design consultant shall compare the energy & cost comparison for each system type.
2. HVAC design should be modular where part of the building system can work independently to cope up for after normal working hours needs and part building operation to conserve energy.

3. Indoor Air Quality (IAQ) & Indoor Environmental Quality (IEQ) should also be considered in the design.
4. Energy recovery should be considered where feasible.
5. A life cycle cost analysis shall be done to show which system is not only energy efficient but cost effective too during its life cycle.
6. Later this should be considered as energy footprint of this project and to be followed in future.

### 8.7.1 Hydronic Systems

- (i) Primary secondary pumping system shall be used to conserve energy.
- (ii) HVAC pumping systems that include control valves shall be designed for variable fluid flow and shall be capable of reducing pump flow rates to:
  - (a) 50% of the design flow rate, or
  - (b) Less of the design flow rates for proper operation of the chillers or boilers.
- (iii) Water cooled air-conditioning or heat pump units with a circulation pump motor greater than or equal to 5 hp (3.7 kW) shall have control devices on each water-cooled air-conditioning or heat pump unit that are interlocked with the compressor to shut off condenser water flow when the compressor is not operating. Pump motors greater than or equal to 5 hp (3.7 kW) shall be controlled by variable speed drives.

## 8.8 CONTROLS

### 8.8.1 System Control

All mechanical cooling and heating systems shall be controlled by automated controls preferably through a building management system using Direct Digital Control (DDC) system that:

1. Capable of maintaining required in door temperature & Humidity
2. Can start and stop the system under different schedules for different days, usage types & times per week,
3. Is capable of retaining programming and time setting during a loss of power for a period of at least 10 hours, and
4. Includes an accessible manual override that allows temporary operation of the system.
  - a. Should be capable of reporting maintenance requirements of the components (Maintenance Management System)
  - b. Capable of monitoring, alarms and reporting energy consumption
  - c. Capable of communicating with Fire systems installed in the facility.

### 8.8.2 HVAC Systems Zone Set Points (Temperature Control)

The building project's HVAC systems shall be programmed to allow centralized demand reduction (DR) in response to a signal from a centralized

contact or software point in accordance with the following:

1. The controls shall be programmed to automatically adjust upward the zone operating cooling set points by a minimum of 3°F (1.7°C).
2. The controls shall be programmed to automatically adjust downward the zone operating heating set points by a minimum of 3°F (1.7°C).
3. The controls shall be programmed to automatically adjust downward the zone operating cooling set points by a minimum of 2°F (1.1°C).
4. The automated DR strategy shall include both ramp-up and ramp-down logic to prevent the building peak demand from exceeding that expected without the DR implementation.

#### **8.8.2.1 Exception**

Systems serving areas deemed by the owner to be critical in nature with regards to temperature such as sensitive electronic equipment or storage spaces requiring lower temperature than the zone operating temperature.

#### **8.8.3 Variable-Speed Equipment**

1. For HVAC equipment with variable-speed control, the controls shall be programmed to allow automatic adjustment of the maximum speed of the equipment to 90% of design speed during automated DR events.
2. Airflow adjustments shall not decrease the supply airflow rate below the level that would result in outdoor airflow being below the minimum required outdoor airflow rates, or that would cause adverse building pressurization problems.

#### **8.8.4 Fault Detection and Diagnostics (FDD)**

A fault detection and diagnostics (FDD) system is preferred to be installed in new buildings to monitor the performance of the building's HVAC system and detect faults in the system. The FDD system shall:

1. Include permanently installed devices to monitor HVAC system operation.
2. Sample the HVAC system performance not more than once per hour.
3. Automatically identify, display, and report system faults.
4. Automatically notify service personnel of identified fault conditions.
5. Automatically provide prioritized recommendations for fault repair based on analysis of collected data; and
6. Be capable of tracking and recording a history of identified faults, from identification through repair completion.
7. Capable of reporting any increase in Energy usage.

##### **8.8.4.1 Exceptions**

1. Buildings with gross floor area less than 25,000 ft<sup>2</sup> (2500 m<sup>2</sup>).
2. Individual tenant spaces with gross floor area less than 10,000 ft<sup>2</sup> (1000 m<sup>2</sup>).
3. Residential buildings with less than 10,000 ft<sup>2</sup> (1000 m<sup>2</sup>) of common area.

### 8.8.5 Mechanical Ventilation

Each mechanical ventilation system (supply and/or exhaust) shall be equipped with a readily accessible switch or other means for shut off or for volume reduction or shut off when full ventilation is not required. Automatic or gravity dampers that close when the system is not operating shall be provided for outdoor air intake and exhausts. Automatic or manual dampers installed for the purpose of shutting off ventilation systems shall be designed with tight shutoff characteristics to minimize air leakage.

#### 8.8.5.1 Exceptions

Manual dampers for outdoor intakes may be used in the following cases:

- a. For single and multi-family residential buildings.
- b. Dampers are not required when ventilation air flow is less than 100 ft<sup>3</sup>/min (0.047 m<sup>3</sup>/s).

### 8.8.6 Non-Residential Kitchen Space

Non-residential kitchen space shall be designed with an exhaust air and make up air balance such that the space is never under a positive pressure with reference to adjacent space.

## 8.9 EQUIPMENT SELECTION

HVAC Equipment shall meet or exceed the minimum performance at the specified rating conditions when tested in accordance with the specified test procedures. The Equipment shall satisfy all stated requirements unless mentioned otherwise.

### 8.9.1 Equipment Selection (Minimum Equipment Efficiencies)

**Note:** These tables are incorporated from ASHRAE 90.1-2004, values from newer versions of ASHRAE 90.1 can also be used.

Table 8-3. Air Conditioners and Condensing Units					
Equipment Type	Size Category	Heating Section Type	Sub-Category or Rating Condition	Minimum Efficiency <sup>a</sup>	Test Procedure <sup>b</sup>
Air Conditioners, Air Cooled	<65,000 Btu/h <sup>c</sup>	All	Split System	12.0 SEER	ARI 240/210
			Single Package	12.0 SEER	
Through-the- Wall, Air Cooled	≤30,000 Btu/h <sup>c</sup>	All	Split System	12.0 SEER	
			Single Package	12.0 SEER	
Small-Duct High-Velocity, Air Cooled	< 65,000 Btu/h <sup>c</sup>	All	Split System	10 SEER	
Air Conditioners, Air Cooled	≥ 65,000 Btu/h and < 135,000 Btu/h	Electric Resistance (Or none)	Split System and Single Package	10.3 EER	
		All other	Split System and Single Package	10.1 EER	
	≥ 135,000 Btu/h and < 240,000 Btu/h	Electric Resistance (Or none)	Split System and Single Package	9.7 EER	
		All other	Split System and Single Package	9.5 EER	
	≥ 240,000 Btu/h and < 760,000 Btu/h	Electric Resistance (Or none)	Split System and Single Package	9.5 EER 9.7 IPLV	
		All other	Split System and Single Package	9.3 EER 9.5 IPLV	
	≥ 760,000 Btu/h	Electric Resistance (Or none)	Split System and Single Package	9.2 EER 9.4 IPLV	
		All other	Split System and Single Package	9.0 EER 9.2 IPLV	



Equipment Type	Size Category	Heating Section Type	Sub-Category or Rating Condition	Minimum Efficiency <sup>a</sup>	Test Procedure <sup>b</sup>	
Air Conditioners, Water and Evaporatively Cooled	< 65,000 Btu/h	All	Split System and Single Package	12.1 EER	ARI 240/210	
	≥ 65,000 Btu/h and <135,000 Btu/h	Electric Resistance (or none)	Split System and Single Package	11.5 EER	ARI 360/340	
		All other	Split System and Single Package	11.3 EER		
	≥ 135,000 Btu/h and <240,000 Btu/h	Electric Resistance (Or none)	Split System and Single Package	11.0 EER		
		All other	Split System and Single Package	10.8 EER		
	≥ 240,000 Btu/h	Electric Resistance (Or none)	Split System and Single Package	1.0 1 EER 10.3 IPLV		
		All other	Split System and Single Package	10.8 EER 10.1 IPLV		
	Condensing Units, Air Cooled	≥ 135,000 Btu/h	-	-		10.1 EER 11.2 IPLV
Condensing Units, Water or Evaporatively Cooled	≥ 135,000 Btu/h	-	-	13.1 EER 13.1 IPLV		
<p>a PLVs and part load rating conditions are only applicable to equipment with capacity modulation.</p> <p>b ASHRAE 90.1-2004 contains a complete specification of the referenced test procedure, including the referenced year version of the test procedure.</p>						

**Table 8-4. Electrically Operated Unitary and Applied Heat Pumps**

Equipment Type	Size Category	Heating Section Type	Sub-Category Or Rating Condition	Minimum Efficiency <sup>a</sup>	Test Procedure <sup>b</sup>		
Air Cooled (Cooling Mode)	<65,000 Btu/h <sup>c</sup>	All	Split System Single Package	12.0 SEER	ARI 240/210		
				12.0 SEER	-		
Through the Wall (Air Cooled, Cooling Mode)	<30,000 Btu/h <sup>c</sup>	All	Split System	12.0 SEER	-		
			Single Package	12.0 SEER			
Small-Duct High-Velocity (Air Cooled, Cooling Mode)	< 65,000 Btu/h <sup>c</sup>	All	Split System	10 SEER	-		
Air Cooled (Cooling Mode)	>65,000 Btu/h and <135,000 Btu/h	Electric Resistance (Or none)	Split System and Single Package	10.1 EER	ARI 360/340		
		All other	Split System and Single Package	9.9EER			
	>135,000 Btu/h and <240,000 Btu/h	Electric Resistance (Or none)	Split System and Single Package	9.3 EER			
		All other	Split System and Single Package	9.1 EER			
	>240,000 Btu/h	Electric Resistance (Or none)	Split System and Single Package	9.0 EER 9.2IPLV			
		All other	Split System and Single Package	8.8 EER 9.0IPLV			
	Water-Source (Cooling Mode)	<17,000Btu/h	All	860F Entering Water		11.2 EER	ISO-1-13256
		> 17,000 Btu/h and <65,000 Btu/h	All	860F Entering Water		12.0 EER	ISO-1-13256
>65,000 Btu/h and < 135,000 Btu/h		All	860F Entering Water	12.0EER	ISO-1-13256		
Ground water-Source (Cooling Mode)	<135,000 Btu/h	All	590F Entering Water	16.2 EER	ISO-1-13256		
Ground Source (Cooling Mode)	< 135,000 Btu/h	All	770F Entering Water	13.4 EER	ISO-1-13256		
Air Cooled (Heating Mode)	<65,000 Btu/hc (Cooling Capacity)	-	Split System	7.4 HSPF	ARI 240/210		
			Single Package	7.4 HSPF			
Through the Wall (Air Cooled, Heating Mode)	<30,000 Btu/hc (Cooling capacity)	-	Split System	7.4 HSPF			
			Single Package	7.4 HSPF			
Small-Duct High-Velocity (Air Cooled, Heating Mode)	< 65,000 Btu/hc (Cooling capacity)	-	Split System	6.8 HSPF	ARI 240/210		

Air Cooled (Heating Mode)	>65,000 Btu/h and <135,000 Btu/h (Cooling Capacity)	-	47°F db/43°F wb Outdoor air	3.2 COP	ARI 360/340
			17°F db/15°F wb Outdoor air	2.2 COP	
	>135,000 Btu/h (Cooling Capacity)	-	47°F db/43°F wb Outdoor air	3.1 COP	
			17°F db/15°F wb Outdoor air	2.0 COP	
Water-Source (Heating Mode)	<135,000 Btu/h (Cooling Capacity)	-	68°F Entering Water	4.2 COP	ISO-1-13256
Groundwater-Source (Heating Mode)	<135,000 Btu/h (Cooling Capacity)	-	50°F Entering Water	3.6 COP	ISO-1-13256
Ground Source (Heating Mode)	< 135,000 Btu/h (Cooling Capacity)	-	32°F Entering Water	3.1 COP	ISO-1-13256

1. Above table shows the Minimum Efficiency Requirements.
2. IPLVs and Part load rating conditions are only applicable to equipment with capacity modulation.
3. ASHRAE 2004-90.1 contains a complete specification of the referenced test procedure, including the referenced year version of the test procedure.

**Table 8-5. Water Chilling Packages Minimum Efficiency Requirements**

Equipment Type	Size Category	Minimum Efficiency	Test Procedure
Air Cooled	All Capacities	2.80 COP 3.05 IPLV	ARI590/550
Water Cooled, Electrically Operated, (Reciprocating)	All Capacities	4.20 COP 5.05 IPLV	ARI590/550
Water Cooled, Electrically Operated, (Rotary Screw and Scroll)	<150 tons	4.45 COP 5.20 IPLV	ARI590/550
	≥150 tons and <300 tons	4.90 COP 5.60 IPLV	
	≥300 tons	5.50 COP 6.15 IPLV	
Water Cooled, Electrically Operated, Centrifugal	<150 tons	5.00 COP 5.25 IPLV	ARI590/550
	≥150 tons and <300 tons	5.55 COP 5.90 IPLV	
	≥300 tons	6.10 COP 6.40 IPLV	
Water-Cooled Absorption, Single Effect	All Capacities	0.7 COP	
Absorption Double Effect, Indirect-Fired	All Capacities	1.00 COP 1.05 IPLV	
Absorption Double Effect, Direct-Fired	All Capacities	1.00 COP 1.00 IPLV	

*Minimum Efficiency: The chiller equipment requirements do not apply for chillers used in low-temperature applications where the design leaving fluid temperature is <40°F.*

*Test Procedure: ASHRAE 2004-90.1 contains a complete specification of the referenced test procedure, including the referenced year version of the test procedure.*

**Table 8-6. Minimum Efficiency Requirements for Air Conditioners**

Equipment Type	Size Category (Input)	Subcategory or Rating Condition	Minimum Efficiency	Test Procedure
PTAC (Cooling Mode) New Construction	All Capacities	95°F db Outdoor air	12.5-(0.213 x Cap/1000) <sup>c</sup> EER	ARI 310/380
PTAC (Cooling Mode) Replacements <sup>b</sup>	All Capacities	95°F db Outdoor air	10.9 - (0.213 x Cap/1000) <sup>c</sup> EER	
PTHP (Cooling Mode) New Construction	All Capacities	95°F db Outdoor air	12.3 - (0.213 x Cap/1000) <sup>c</sup> EER	
PTHP (Cooling Mode) Replacements <sup>b</sup>	All Capacities	95°F db Outdoor air	10.8-(0.213 x Cap/ 1000) <sup>c</sup> EER	
PTHP (Heating Mode) New Construction	All Capacities	-	3.2 - (0.026 x Cap/1000) <sup>c</sup> COP	
PTHP (Heating Mode) Replacements <sup>b</sup>	All Capacities	-	2.9 - (0.026 x Cap/1000) <sup>c</sup> COP	
SPVAC (Cooling Mode)	All Capacities	95°F db/75°F wb Outdoor air	8.6 EER	ARI 390
SPVHP (Cooling Mode)	All Capacities	95°F db/75°F wb Outdoor air	8.6. EER	
SPVHP (Heating Mode)	All Capacities	47°F db/43°F wb Outdoor air	2.7 COP	
Room Air Conditioners, with Louvered Sides	<6000 Btu/h	-	9.7 SEER	ANSV AHAM RAC-I
	≥6000 Btu/h and <8000 Btu/h	-	9.7 EER	
	≥8000 Btu/h and <14,000 Btu/h	-	9.8 EER	
	≥14,000 Btu/h and <20,000 Btu/h	-	9.7 SEER	
	≥20,000 Btu/h	-	8.5 EER	
Room Air Conditioners, Without Louvered Sides	<8000 Btu/h	-	9.0 EER	
	≥8000 Btu/h and <20,000 Btu/h	-	8.5 EER	
	≥20,000 Btu/h	-	8.5 EER	
Room Air Conditioner Heat Pumps with Louvered Sides	<20,000 Btu/h	-	9.0 EER	
	≥20,000 Btu/h	-	8.5 EER	
Room Air Conditioner Heat Pumps without Louvered Sides	<14,000 Btu/h	-	8.5 EER	
	≥14,000 Btu/h	-	8.0 EER	

a ASHRAE 2004-90.1 contains a complete specification of the referenced test procedure, including the referenced year version of the test procedure.

b Replacement units must be factory labeled as follows: "MANUFACTURED FOR REPLACEMENT APPLICATIONS ONLY; NOT TO BE INSTALLED IN NEW CONSTRUCTION PROJECTS," Replacement efficiencies apply only to units with existing sleeves less than 16 in. high and less than 42 in. wide.

c Cap means the rated cooling capacity of the product in Btu/h. If the unit's capacity is less than 7000 Btu/h, use 7000 Btu/h in the calculation. If the unit's capacity is greater than 15,000 Btu/h, use 15,000 Btu/h in the calculation.

Table 8-7. Warm Air Furnaces

(Warm Air Furnaces and Combination Warm Air Furnaces/Air-Conditioning Units, Warm Air Duct Furnaces and Unit Heaters)

Equipment Type	Size Category (Input)	Subcategory or Rating Condition	Minimum Efficiency <sup>a</sup>	Test Procedure <sup>b</sup>
Warm Air Furnace, Gas-Fired	<225,000 Btu/h	-	78% AFUE or 80% $E_t^d$	DOE 10 CFR Part 430 or ANSI Z21.47
	≥225,000 Btu/h	Maximum Capacity <sup>d</sup>	80% $E_c^c$	ANSI Z21.47
Warm air Furnace, Oil-Fired	<225,000 Btu/h	-	78% AFUE or 80% $E_t^d$	DOE 10 CFR Part 430 or UL 727
	≥225,000 Btu/h	Maximum Capacity <sup>e</sup>	81% $E_t^f$	UL 727
Warm Air Duct Furnaces, Gas-Fired	All Capacities	Maximum Capacity <sup>e</sup>	80% $E_c^g$	ANSI Z83.9
Warm Air Unit Heaters, Gas Fired	All Capacities	Maximum Capacity <sup>e</sup>	80% $E_c^g$	ANSI Z83.8
Warm Air Unit Heaters, Oil-Fired	All Capacities	Maximum Capacity <sup>e</sup>	80% $E_c^g$	UL 731

<sup>a</sup>  $E_t$  = thermal efficiency. See test procedure for detailed discussion.

<sup>b</sup> ASHRAE 90.1-2004 contains a complete specification of the referenced test procedure, including the referenced year version of the test procedure.

<sup>c</sup>  $E_c$  = combustion efficiency. Units must also include an interrupted or intermittent ignition device (IIG), have jacket losses not exceeding 0.75% of the input rating, and have either power venting or a flue damper. A vent damper is an acceptable alternative to a flue damper for those furnaces where combustion air is drawn from the conditioned space.

<sup>d</sup> Combination units not covered by NAECA (3-phase power or cooling capacity greater than or equal to 65,000 Btu/h) may comply with either rating.

<sup>e</sup> Minimum and maximum ratings as provided for and allowed by the unit's controls.

<sup>f</sup>  $E_t$  thermal efficiency. Units must also include an interrupted or intermittent ignition device (IID), have jacket losses not exceeding 0.75% of the input rating, and have either power venting or a flue damper. A vent damper is an acceptable alternative to a flue damper for those furnaces where combustion air is drawn from the conditioned space

<sup>g</sup>  $E_c$  = combustion efficiency. See test procedure for detailed discussion.

Table 8-8. Gas and Oil-Fired Boilers-Minimum Efficiency Requirements				
Equipment Type	Size Category (Input)	Subcategory or Rating Condition	Minimum Efficiency <sup>b</sup>	Test Procedure <sup>c</sup>
Boilers, Gas-Fired	<300,000 Btu/h	Hot Water	80% AFUE	DOE 10 CFR Part 430
		Steam	75% AFUE	
	≥300,000 Btu/h and ≤2,500,000 Btu/h	Maximum Capacity <sup>d</sup>	75% $E_t$ <sup>b</sup>	H.I. Htg Boiler Std.
		>2,500,000 Btu/h <sup>a</sup>	Hot Water	
	>2,500,000 Btu/h <sup>a</sup>	Steam	80% $E_c$	
Boilers, Oil-Fired	<300,000 Btu/h	-	80% AFUE	DOE 10 CFR Part 430
	≥300,000 Btu/h and ≤2,500,000 Btu/h	Maximum Capacity <sup>d</sup>	78% $E_t$ <sup>b</sup>	DOE 10 CFR Part 430 H.I. Htg Boiler Std.
		-	-	
	>2,500,000 Btu/h <sup>a</sup>	Hot Water	83% $E_c$	
>2,500,000 Btu/h <sup>a</sup>	Steam	83% $E_c$		
Oil-Fired (Residual)	≥300,000 Btu/h and ≤2,500,000 Btu/h	Maximum Capacity <sup>d</sup>	78% $E_t$ <sup>b</sup>	H.I. Htg Boiler Std.
		-	-	
	>2,500,000 Btu/h <sup>a</sup>	Hot Water	83% $E_c$	
	>2,500,000 Btu/h <sup>a</sup>	Steam	83% $E_c$	

*a. These requirements apply to boilers with rated input 800,000,000 Btu/h or less that are not packaged boilers, and to all packaged boilers. Minimum efficiency requirements for boilers cover all capacities of packaged boilers.*  
*b.  $E_t$  = thermal efficiency. See reference document for detailed information.*  
*c. ASHRAE 90.1-2004 contains a complete specification of the referenced test procedure, including the referenced year version of the test procedure.*  
*d. Minimum and maximum ratings as provided for and allowed by the units' controls.*

Table 8-9. Performance Requirements for Heat Rejection Equipment				
Equipment Type	Total System Heat Rejection Capacity at Rated Conditions	Subcategory or Rating Condition	Performance Required <sup>a,b</sup>	Test Procedure <sup>c</sup>
Propeller or Axial Fan Cooling Towers	All	95°F Entering Water 85°F Leaving Water 75°F wb <i>Outdoor air</i>	≥38.2 gpm/hp	CTI ATC-105
Centrifugal Fan Cooling Towers	All	95°F Entering Water 85°F Leaving Water 75°F wb <i>Outdoor air</i>	≥20.0 gpm/hp	CTI ATC-105
Air-Cooled Condensers	All	125°F Condensing Temperature R-22 Test Fluid 190°F Entering Gas Temperature 15°F Subcooling 95°F Entering db	≥176,000 Btu/h.hp	ARI460
<p>a For purposes of this table, cooling tower performance is defined as the maximum flow rating of the tower divided by the fan nameplate rated motor power.</p> <p>b For purposes of this table, air-cooled condenser performance is defined as the heat rejected from the refrigerant divided by the fan nameplate rated motor power.</p> <p>c ASHRAE 90.1-2004 contains a complete specification of the referenced test procedure, including the referenced year version of the test procedure.</p>				

**8.9.2 Insulation Piping and Ductwork**

Piping shall be insulated in accordance with table the Table 5.1 of chapter 5 of this code.

**8.9.3 Cooling Towers/Condenser Water**

1. All cooling towers and closed-circuit fluid coolers shall have preferably variable drives controlling the fans.
2. Cooling towers shall have provisions for automatic blow down based on cooling water conductivity or total dissolved solids. Feed tank and pumps shall be provided for chemical treatment.
3. Cooling towers shall be designed in accordance with the requirements of manufacturer of Non- Industrial Cooling Towers & following ASHRAE guidelines.
4. Cooling towers shall be located downwind of any adjacent facility or building. Cooling towers shall also be separated by not less than 15 m (49.5 ft.) from adjacent facilities.
5. Make-up water line for cooling towers shall have an air gap between the termination of the make-up line and the maximum water level of the cooling tower reservoir. This air gap shall be a minimum of two times the diameter of the make-up line.

Condenser water treatment, shall have the following:

- a. Condenser water treatment, including scale inhibitors, corrosion inhibitors, dispersants/antifoulants and biocide as a minimum. Condenser water treatment shall comply with the ASHRAE Applications Handbook, Chapter on Water Treatment.

- b. Blow down shall be automatic and controlled by a conductivity controller set at the maximum allowable concentration of Total Dissolved Solids (TDS).
- c. Closed chilled or hot water systems shall be treated with a corrosion inhibitor. This corrosion inhibitor shall be a buffered, nitrite-based product, with sodium nitrite residual in the range of 700 to 1200 ppm or molybdate in the range of 250-350 ppm; and with a pH of 7 or higher.

## 8.10 DESIGN DOCUMENTS

Design documentation is an important part of the HVAC project that should include Design, installation, commissioning, TAB, O&M and energy monitoring.

### 8.10.1 Design Documentation Requirements

Design Execution Specifications and Design Drawings shall be prepared for each project. These Specifications shall include all mechanical design requirements for air conditioning and refrigeration (HVAC). Specifications shall be complete and include work description, references to drawings, standards, and description of construction materials.

### 8.10.2 Drawings

1. HVAC drawings shall be provided with sufficient details to permit the construction of a complete facility.
2. Drawings shall include a list of drafting symbols / abbreviations used, and equipment schedules.
3. All symbols and abbreviations on HVAC drawings shall be consistent with SMACNA & ASHRAE
4. All construction drawings shall be revised to show “as built” conditions.
5. On one of the drawings of each HVAC system, Design Data, including the following items, shall be shown:
  - a) Outside air conditions used for load calculations
  - b) Indoor design conditions
  - c) Total sensible cooling load with a breakdown to its components, i.e., external heat gain, heat from lights, people, etc.
  - d) Total latent cooling load, with breakdown
  - e) Grand total cooling load
  - f) Heating load
  - g) Outside air intake
  - h) Chilled water (if any) flow rate, temperature rise and pressure drop.
  - i) Entering and leaving air conditions at cooling coil; and
  - j) Total pressure drops of air handling system with a breakdown to components, i.e., pressure drop through supply/return ducting, coils, filters, etc.
6. Psychrometric charts shall be shown on one of the HVAC drawings for each HVAC system of 10 tons and larger.



### 8.10.2.1 Exemption: Residential buildings

1. System curves superimposed with fan curves shall be shown on one of the HVAC drawings, for each HVAC system of 10 tons and larger.
2. As built drawings: The original drawings shall be updated to “as built” conditions when the construction of a project is completed.
3. Vendor drawings shall be specified by the originator of the material requisition and shall conform to the requirements.
4. HVAC sequence of operation shall be shown on one of the HVAC drawings, for each HVAC system of 10 tons and larger which will be the basis of controls vendors design.

### 8.10.3 Equipment Schedules

Equipment schedules shall be included on one of the HVAC drawings with information necessary for bidding, purchasing, and installation of all HVAC equipment. Schedules shall contain all required data, such as type of equipment, quantity, temperature, medium handled, pressure and pressure drop, design conditions, etc. Area served and location shall be shown on the drawing plans. Each item of equipment schedule shall have the following:

- a. Equipment number.
- b. Air (water) quantities, from each source.
- c. Equipment rpm.
- d. Total pressure drops, across each portion of equipment.
- e. Unit type.
- f. Manufacturer and model number.
- g. Motor type, size, rpm, kW (hp), volts/phase/hertz.

In addition, the following specific data shall be given:

- a) Filter: type, efficiency, number, size, pressure drop (clean/dirty).
- b) Coil: sensible heat, total heat, EAT (DB/WB), LAT (DB/WB)
- c) Chillers: capacity, compressor input, EWT, LWT,
- d) water flow pressure drops, cond. ambient temp., cond. fans No. and motor size, (or condenser supply, condenser return), refrigerant.
- e) Pumps: capacity, total head, type, duty.
- f) Fans: type, capacity, static press., wheel diameter, drive, interlocks, accessories.
- g) Duct Htr: airflow, capacity, stages, power and control voltages.
- h) Air Distr.: size, symbol, duty, air pattern, accessories.
- i) Humidifier, type capacity etc
- j) Energy recovery type & details

## 8.11 COMMISSIONING

Commissioning is a quality-focused process for enhancing the delivery of a project for verifying and documenting that the HVAC systems, energy & controls are planned, designed, installed, tested, and include plans for operation and maintenance to meet specified requirements.

### 8.11.1 Preliminary Commissioning Report

1. The preliminary commissioning report shall include the following:
2. Required performance of commissioned equipment, systems, assemblies, and results of testing and verification
3. Summary of compliance of the HVAC System and its components, assemblies, controls, and systems with required provisions of this code
4. Issues and resolution logs, including itemization of deficiencies found during verification, testing, and commissioning that have not been corrected at the time of report preparation.
5. Deferred tests that cannot be performed at the time of report preparation.
6. Documentation of the training of operating personnel and building occupants on commissioned systems, and a plan for the completion of any deferred trainings not completed at the time of report preparation.
7. A plan for the completion of commissioning and training, including climatic and other conditions required for performance of the deferred tests.

### 8.11.2 Final Commissioning Report

The construction documents shall require the commissioning provider to provide a final commissioning report to the owner before completion of the contractor's general warranty period.

This report shall be reviewed by respective authority and any discrepancies should be resolved involving design consultant.

## 8.12 TESTING, ADJUSTING AND BALANCING (TAB)

Testing, Adjusting and Balancing (TAB) is a critical process used to ensure that heating, ventilation, and air conditioning (HVAC) systems in buildings are operating efficiently and effectively. The TAB process involves a series of tests and adjustments that are performed on HVAC systems to ensure that they are delivering the right amount of air at the right temperature, and in the right locations throughout the building.

The primary goal of TAB is to optimize HVAC system performance to ensure energy efficiency and occupant comfort. The TAB process typically involves the following steps:

- A. Testing:** A series of tests are performed to measure the performance of the HVAC system. This includes measuring air flow rates, temperatures, pressures, and other variables.
- B. Adjusting:** Based on the test results, adjustments are made to the HVAC system to ensure that it is operating efficiently and effectively. This includes adjusting dampers, valves, and other components to optimize air flow rates and temperatures.
- C. Balancing:** Once the adjustments have been made, the HVAC system is balanced to ensure that it is delivering the right amount of air at the right temperature and in the right locations throughout the building. This involves adjusting the airflow distribution system to ensure that the air is being distributed evenly throughout the building.

By performing the TAB process on HVAC systems, building owners and managers can ensure that their systems are operating at peak performance, which can lead to significant energy savings and improved occupant comfort. TAB is often required by building codes and standards, and is typically performed by certified professionals who are trained in HVAC system testing and balancing.

### 8.12.1 General Requirements

Construction documents shall require that all HVAC systems be balanced in accordance with generally accepted engineering standards. Construction documents shall require that a written testing, commissioning, and balance report be provided to the owner or the designated representative of the building owner for HVAC systems serving zones with a total conditioned area exceeding 5000m<sup>2</sup> (50000 ft<sup>2</sup>). Test procedure should follow guidelines by NEBB. All building environmental systems and components shall be checked and adjusted to produce the design objectives. It shall include:

- a) The balance of air and water distribution adjustment of total system to provide design quantities.
- b) Electrical measurement
- c) Verification of performance of all equipment and automatic controls, sound and vibration measurement, when required.
- d) Energy consumptions as stipulated in the design.

### 8.12.2 Economizers

#### 8.12.2.1 Air Side Economizer

Each individual cooling fan system that has a design supply capacity over 2,500 cfm (1,200 l/s) and a total mechanical cooling capacity over 75,600 Btu/hr (22.2 kW or 6.3 tons) shall include either:

- A. An air economizer capable of modulating outside-air and return-air dampers to supply 100 percent of the design supply air quantity as outside-air; or
- B. Heat recovery units are recommended to be installed where appropriate

#### 8.12.2.2 Testing Air Side Economizer

- A. Air-side economizers shall be tested in the field to ensure proper operation.
- B. Air economizers installed by the HVAC system equipment manufacturer and certified as being factory calibrated and tested per relevant ASHRE/ARI Standard procedures.

### 8.12.3 Air System Balancing

Air systems shall be balanced in a manner to first minimize throttling losses. Then, for fans with fan system power greater than 1.0 hp (0.75 kW), fan speed shall be adjusted to meet design flow conditions. System should be balanced within 10% of the designed air flow. Any differences should be resolved with consultation with the design consultant.

### 8.12.3.1 Hydronic System Balancing

Hydronic systems shall be proportionately balanced in a manner to first minimize throttling losses; then the pump impeller shall be trimmed (as a last resort), or pump speed shall be adjusted to meet design flow conditions.

The above tests shall be accomplished by:

- I. checking installations for conformity to design
- II. measurement and establishment of the fluid quantities
- III. recording and reporting the results.

A complete system test reports shall be provided on air and water movement system (If Hydronic) as follows:

- a) Record data on water side and air side of all air handling units, fans, coils, water chillers, condensers, etc. Data shall include all water and airflow, motor, starter heaters, manufacturer, nameplate data.
- b) Balance air distribution system within + 10% of air quantities shown on project drawings and record actual readings taken.
- c) Adjust all chilled water balance valves for quantities to within 5% of values shown on project drawings and record actual readings.
- d) Check operation of all controls to ensure that all actuators cycle in accordance with the designed action of the controlling device and the sequence of operation.
- e) Provide test points and plugs or covers for all openings in duct.

### 8.12.4 Testing Organization

The Testing and Balancing (TAB) work for HVAC installation shall be accomplished by a Balancing Contractor who has:

- A. An organization whose regular activities include testing, adjusting and balancing environmental systems.
- B. An organization which utilized only regular employees experienced and trained specifically in the total balancing of environmental systems; and
- C. An organization which has satisfactorily balanced at least five systems of comparable type and size.
- D. Preferred if NEEB or any other respective approved org

### 8.12.5 Test Procedures

The Test and Balance Organization shall perform testing, adjustment and balancing of all equipment and systems using general procedure for testing and balancing following:

- a) ASHRAE STD 111 (latest edition), Practices for Measurement, Testing, Adjusting and Balancing of Heating, Ventilation, Air Conditioning and Refrigeration Systems

- b) ASHRAE Applications Handbook (latest edition), Chapter on “Testing, Adjusting and Balancing”;
- c) SMACNA (latest edition), “HVAC Systems - Testing, Adjusting and Balancing.”
- d) NEBB “Testing, Adjusting and Balancing of Environmental Systems.”
- e) The system balance contractor shall verify installation of mechanical systems and equipment in accordance with design and construction drawings.

#### **8.12.6 Test and Balance Report**

The report shall include the detailed information of either:

- a) AABC “National Standards for Field Measurement and Instrumentation, (US)
- b) NEBB “Procedural Standards for Testing, Balancing and Adjusting of Environmental Systems.” (US)

### **8.13 OPERATION & MAINTENANCE**

HVAC operations and maintenance (“O&M”) are the practices that keep the mechanical systems working at peak performance during the life of the building. In order to maintain energy footprint of a system, Operation & Maintenance is vital and should be carried out as stipulated in the design.

1. Design consultant shall prepare & provide an O& M manual for the O&M Staff to follow
2. O&M staff/facility managers must be trained to take over and maintain the system.
3. Use of MMS (Maintenance Management System) is highly recommended
4. A properly executed O&M can not only save the system from premature failure but also maintain its energy footprints.

### **8.14 RECOMMENDED VOLUNTARY ADOPTION**

#### **8.14.1 Alternate Energy**

The use of energy recovery system, geothermal energy, solar systems and other renewable energy systems is encouraged for adoption in buildings as an alternative to conventional heating, ventilating and cooling systems.

### **8.15 COMPLIANCE DOCUMENTATION**

Compliance documents should include plans, drawings, specifications, and other relevant documentation that demonstrate compliance with the relevant building codes and regulations. These documents should be submitted to the relevant authorities for review and approval.



# 9

## SERVICE WATER HEATING

The Service Water Heating chapter of the Energy Conservation Building Code 2023 focuses on promoting energy efficiency in water heating for activities like bathing and cooking in buildings. It offers guidelines for the design, installation, operation, and maintenance of water heating systems to help reduce energy consumption, lower utility bills, and minimize carbon footprints. The chapter includes minimum efficiency standards for water heaters and piping systems and encourages the use of renewable energy sources.

## CHAPTER NO 9

# SERVICE WATER HEATING

---

## 9.1 INTRODUCTION

The Service Water Heating chapter of the Energy Conservation Building Code 2023 is designed to promote energy efficiency in the heating of water used for various purposes in buildings such as bathing, cleaning, cooking, and laundry. It provides guidelines for the design and installation of service water heating systems that can help building owners and occupants reduce their energy consumption, lower their utility bills, and minimize their carbon footprint.

The chapter covers a range of topics related to service water heating, including system design, equipment selection, installation, operation, and maintenance. It sets out minimum efficiency standards for water heaters, piping systems, and other components, and provides recommendations for the use of renewable energy sources.

## 9.2 MANDATORY REQUIREMENTS

All service water heating equipment and systems shall comply with the mandatory provisions of this Section.

### 9.2.1 Piping Insulation

Piping insulation shall comply with the Table 5.1 of chapter 5 of this code.

### 9.2.2 Swimming Pools

#### 9.2.2.1 Pool Covers

Heated pools shall be provided with a vapor retardant pool cover on or at the water surface. Pools are heated to more than 90°F (32°C) shall have a pool cover with a minimum insulation value of R-12 (R-2.1).

#### 9.2.2.2 Exception

Pools deriving over 60% of their energy from site-recovered energy or solar energy source are exempt.

#### 9.2.2.3 Pool Heaters

Pool heaters shall be equipped with a readily accessible on-off switch to allow shutting off the heater without adjusting the thermostat setting. Pool heaters fired by natural gas shall not have continuously burning lights.

### 9.3 VOLUNTEER ADOPTION

Buildings with a centralized system may have heat recovery units. The use of solar/ renewable energy for water heating is also recommended for adoption by the buildings with centralized and non-centralized systems. Residential facilities of 420 m<sup>2</sup> (4300 sq.ft) or greater plot area, commercial buildings, hotels and hospitals with centralized system may have solar/ renewable energy for water heating at least one fifth of the design capacity.

### 9.4 CODE IMPLEMENTATION

Competent Authority” will determine the relevant organization responsible for establishing laboratories. These laboratories will be tasked with conducting various tests specified in tables 5.1 and 5.2, given in the chapter 5 of this code related to pipe insulation. Additionally, the human resources required for these laboratories to perform the tests accurately will receive appropriate training and certification in accordance with the adopted code.

### 9.5 DATA COLLECTION

Data will be collected from various relevant locations to monitor the “energy conservation”. Such data can be converted to the “Information” to be used by the “competent forum” for the code review/update as per “actual results”.

### 9.6 COMPLIANCE DOCUMENTATION

Compliance documents should include plans, drawings, specifications, and other relevant documentation that demonstrate compliance with the relevant building codes and regulations. These documents should be submitted to the relevant authorities for review and approval.



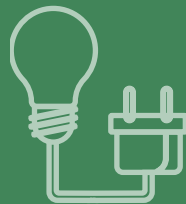

# 10

## LIGHTING

The Lighting chapter of the Energy Conservation Building Code 2023 provides guidelines for energy-efficient and sustainable lighting design in buildings. It establishes minimum requirements for lighting efficiency, controls, and design to reduce energy consumption and greenhouse gas emissions. Based on international standards and best practices, this chapter aims to guide Pakistani building owners, designers, and contractors in enhancing energy efficiency, thereby lowering energy costs and contributing to sustainable building practices.

## CHAPTER NO 10

# LIGHTING

---

## 10.1 INTRODUCTION

The Lighting chapter of the Energy Conservation Building Code 2023 is an important section of the code that provides guidelines for designing and installing lighting systems in buildings that are energy-efficient and environmentally sustainable. The chapter outlines the minimum requirements for lighting efficiency, controls, and design that are necessary to reduce energy consumption and greenhouse gas emissions associated with lighting. The Energy Conservation Building Code 2023 Lighting chapter is based on the latest international standards and best practices in lighting design and technology, and is intended to guide building owners, designers, and contractors in Pakistan to improve the energy efficiency of their buildings. By following the guidelines set out in the Lighting chapter of the Energy Conservation Building Code 2023, building owners can reduce their energy costs and contribute to a more resilient and sustainable buildings for Pakistan.

### 10.1.1 Scope

Lighting systems and equipment shall comply with the mandatory provisions of this section. The lighting requirements in this section shall apply to:

- a. Interior spaces of buildings
- b. Exterior lighting that is powered through the building's electrical service

#### 10.1.1.1 Exceptions

- (a) Emergency lighting that is automatically off during normal building operation and is powered by battery, generator, or other alternate power source; and,
- (b) Self-sustained Lighting i.e., not connected to grid.
- (c) Lighting, including exit signs, that is specially designated as required by a health or life safety statute or ordinance.

### 10.1.2 Lighting Alterations

Any alteration to lighting system in an interior space and exterior of a building shall comply with the Lighting Power Allowance (LPA) and the control requirements of relevant sections of this code.

#### 10.1.2.1 Exceptions

- a. Alterations 20% or less of the connected lighting load does not require the compliance with the requirements of 10.1.2 if the alterations do not increase the installed lighting power

- b. Alterations in which only lamp plus driver are replaced or light-for-light replacement are only required to comply with Lighting Power Density (LPD) requirement of this code.

### 10.1.3 Installed Lighting Power

The cumulative wattage of all type of lighting installed including lamps, ballasts/driver, transformer and control devices other than those exempted.

### 10.1.4 Luminaire Wattage

The wattage of lighting equipment shall be ascertained based on the following guidelines

- i. The wattage of connected lighting equipment shall be manufacturer's labeled maximum wattage.
- ii. The wattage of lighting equipment with remote ballast/ driver or similar devices shall be the total input wattage of all components in the system.
- iii. The wattage of lighting track and plug-in busway which allows the addition of lighting equipment in the future without any change in the wiring system shall be the lesser of
  - a. Specified wattage of lighting equipment
  - b. The wattage limit of permanent current-limiting devices of the system
- iv. The wattage of retrofitted luminaire shall be the manufacturer's labeled input power of the new light source plus driver
- v. The wattage of all other miscellaneous lighting equipment shall be the specified wattage of the lighting equipment

## 10.2 Compliance Path

Lighting systems and equipment shall comply with the following section

### 10.2.1 Requirements for all compliance paths

Lighting systems and equipment shall comply with section 10.1 'General', and section 10.7 'Verification, Testing and commissioning' and one of the following

- a. Section 10.3 'Simplified Building Method Compliance Path'
- b. Section 10.4 'Mandatory Provisions' and Section 10.5 'Building Area Method Compliance Path'
- c. Section 10.4 'Mandatory Provisions' and Section 10.6 'Space-by-Space Method Compliance Path'

### 10.2.2 Prescriptive Requirements

#### 10.2.2.1 Interior Lighting Power Allowance

Interior Lighting Power Allowance for a building shall be ascertained by one of the following methods;

- a. Simplified building Method
- b. Building Area Method
- c. Space by space Method

Adjustment of LPA between different parts of the building with different calculation criteria of compliance is not permitted.

#### **10.2.2.2 Exterior Lighting Power Allowance**

Exterior Lighting power Allowance shall be determined by

- a. Simplified Building Method of calculation
- b. Exterior Lighting Power

### **10.3 SIMPLIFIED BUILDING METHOD COMPLIANCE PATH**

The simplified building method contains the requirements for interior lighting in sections 10.3.1 and exterior lighting in section 10.3.2. This method shall be applied to the buildings with at least 80% of the floor area contains office buildings, retail buildings or school buildings.

#### **10.3.1 Simplified Building Method of Calculating Interior Lighting**

##### **10.3.1.1 Power Allowance**

The new buildings as well as alterations in the existing buildings shall comply with the lighting power allowance and control requirements of Tables 10.3.1-1, 10.3.1-2 and 10.3.1-3

#### **10.3.2 Simplified Building Method of Calculating Exterior Lighting**

##### **10.3.1.2 Power Allowance**

The exterior areas of the building's types mentioned in Section 10.3 shall comply with the lighting power allowance and control requirements of Tables 10.1, 10.2 and 10.3.

Table 10-1. Simplified Building Method for Office Buildings		
Interior Space Type	Interior Lighting Power Allowance	Controls of All Lights in Space
All spaces in office buildings other than parking garages, stairwells, and corridors	0.70 W/ft <sup>2</sup>	All lighting shall be automatically controlled to turn off when the building is either unoccupied or scheduled to be unoccupied. <b>(Exception:</b> Lighting load not exceeding 0.02 W/ft <sup>2</sup> multiplied by the gross lighted area of the building shall be permitted to operate at all times.) Each space shall have a manual control device that allows the occupant to reduce lighting power by a minimum of %50 and to turn the lighting off.
Office spaces less than or equal to 250 ft <sup>2</sup> , classrooms, conference rooms, meeting rooms, training rooms, storage rooms and break rooms	0.70 W/ft <sup>2</sup>	These spaces shall also be controlled by auto-ON occupant sensors.
Office spaces greater than 250 ft <sup>2</sup> and restrooms	0.70 W/ft <sup>2</sup>	These spaces shall also be controlled by occupant sensors.
Stairwells and corridors in office buildings and parking garages	0.70 W/ft <sup>2</sup>	These spaces shall also be controlled by occupant sensors that reduce the lighting power by a minimum of %50 when no activity is detected for not longer than 20 minutes and be controlled to turn off when the building is either unoccupied or scheduled to be unoccupied.
Parking garages	0.13 W/ft <sup>2</sup>	All lighting shall be automatically controlled to turn off during garage nonoperating hours. Lighting shall also be controlled by occupant sensors. Controls shall reduce the power by a minimum of %50 when no activity is detected for not longer than 20 minutes. No single device shall control more than 3600 ft <sup>2</sup> .

Table 10-2. Simplified Building Method for Retails Buildings		
Interior Space Type	Interior Lighting Power Allowance	Controls of all lights in space
All spaces in retail buildings other than parking garages, stairwells, and corridors	1.00 W/ft <sup>2</sup>	All lighting shall be automatically controlled to turn off when the building is either unoccupied or scheduled to be unoccupied. <b>(Exception:</b> Lighting load not exceeding 0.02 W/ft <sup>2</sup> multiplied by the gross lighted area of the building shall be permitted to operate at all times.) Each space shall have a manual control device that allows the occupant to reduce lighting power by a minimum of 50% and to turn the lighting off.
Sales area	1.00 W/ft <sup>2</sup>	These spaces shall also be controlled to reduce the general lighting power by a minimum of 75% during nonbusiness hours, to turn off all lighting other than general lighting during nonbusiness hours, and by continuous daylight dimming controls in spaces with top lighting.
Stock rooms, dressing/fitting rooms, locker rooms, and restrooms	1.00 W/ft <sup>2</sup>	These spaces shall also be controlled by; auto-ON or manual-ON occupant sensors, and continuous daylight dimming controls in spaces with top lighting
Office spaces, conference rooms, meeting rooms, training rooms, storage rooms, break rooms, and utility spaces	1.00 W/ft <sup>2</sup>	These spaces shall also be controlled by; Manual-ON occupant sensors, and continuous daylight dimming controls in spaces with top lighting when the combined input power of the general lights completely or partially within the daylight areas is 150W or greater.
Stairwells and corridors in retail buildings and parking garages	1.00 W/ft <sup>2</sup>	These spaces shall also be controlled by occupant sensors that reduce the lighting power by a minimum of 50% when no activity is detected for not longer than 20 minutes and be controlled to turn off when the building is either unoccupied or scheduled to be unoccupied.
Parking garages	0.13 W/ft <sup>2</sup>	All lighting shall be automatically controlled to turn off during garage nonoperating hours. Lighting shall also be controlled by occupant sensors. Controls shall reduce the power by a minimum of 50% when no activity is detected for not longer than 20 minutes. No single device shall control more than 3600 ft <sup>2</sup> .

Table 10-3. Simplified Building Method for School Buildings		
Interior Space Type	Interior Lighting Power Allowance	Controls of all lights in space
All spaces in school buildings other than parking garages, stairwells, and corridors	0.70 W/ft <sup>2</sup>	All lighting shall be automatically controlled to turn off when the building is either unoccupied or scheduled to be unoccupied. <b>(Exception:</b> Lighting load not exceeding 0.02 W/ft <sup>2</sup> multiplied by the gross lighted area of the building shall be permitted to operate at all times.) Each space shall have a manual control device that allows the occupant to reduce lighting power by a minimum of 50% and to turn the lighting off.
Classrooms, office spaces, conference rooms, meeting rooms, library, storage rooms and break rooms	0.70 W/ft <sup>2</sup>	These spaces shall also be controlled by auto-ON occupant sensors.
Gymnasiums and cafeterias	0.70 W/ft <sup>2</sup>	These spaces shall also be controlled by occupant sensors.
Restrooms	0.70 W/ft <sup>2</sup>	These spaces shall also be controlled by occupant sensors.
Stairwells and corridors in retail buildings and parking garages	0.70 W/ft <sup>2</sup>	These spaces shall also be controlled by occupant sensors that reduce the lighting power by a minimum of 50% when no activity is detected for not longer than 20 minutes and be controlled to turn off when the building is either unoccupied or scheduled to be unoccupied.
Parking garages	0.13 W/ft <sup>2</sup>	All lighting shall be automatically controlled to turn off during garage nonoperating hours. Lighting shall also be controlled by occupant sensors. Controls shall reduce the power by a minimum of 50% when no activity is detected for not longer than 20 minutes. No single device shall control more than 3600 ft <sup>2</sup> .

<b>Table 10 4. Simplified Building Method for Building Exterior</b>		
<b>Interior Space Type</b>	<b>Interior Lighting Power Allowance</b>	<b>Controls of all exterior lights in space</b>
Base allowance	200 W	Luminaires shall be turned off or the power reduced by a minimum of 75% during nonoperating hours.
Facade lighting and special feature areas,	0.10 W/ft <sup>2</sup>	Luminaires shall be turned off or the power reduced by a minimum of 75% during nonoperating hours.
Landscape	0.04 W/ft <sup>2</sup>	Luminaires shall be turned off or the power reduced by a minimum of 75% during nonoperating hours.
Entry doors	14 W/linear foot	Luminaires shall be turned off or the power reduced by a minimum of 75% during nonoperating hours.
Stairs and ramps	0.70 W/ft <sup>2</sup>	No additional controls required.
Parking lots and drives	0.05 W/ft <sup>2</sup>	Luminaires mounted 25 ft or less above grade shall be controlled to reduce the power by at least 50% when no activity is detected for not longer than 15 minutes.
All other areas not listed	0.20 W/ft <sup>2</sup>	Luminaires shall be turned off or the power reduced by a minimum of 75% during nonoperating hours



## 10.4 MANDATORY PROVISIONS

### 10.4.1 Lighting Control

Building lighting controls shall be installed to meet the provisions of Sections 10.4.1.1, 10.4.1.2, 10.4.1.3 and 10.4.1.4

#### 10.4.1.1 Interior Lighting Controls

For each space in the building, the lighting control functions as tabulated in Table 10.6.1 and mentioned here shall be implemented. The control functions specified as 'REQ' are mandatory and shall be implemented.

When using the Space-by-Space method, the space type used for determining control requirements shall be the same space type that is used for determining the LPD allowance.

- a. Local Control: There shall be one or more manual lighting control in the space that controls all the lighting in the space. Each control device shall control an area (i) maximum of 2500 ft<sup>2</sup> if space is less than or equal to 10,000 ft<sup>2</sup>
- b. Automatic Daylight Responsive Control: In any space where the combined input power of all *general* lighting is 150W or greater, the general lighting shall be controlled by photocontrols.
- c. The control system shall have the following features
  - The calibration adjustment control shall be located no higher than 10 ft above the furnished floor.
  - The photocontrol shall reduce the electric lighting power in response to available daylight using continuous dimming to 20% or less or even turn off the light in case of abundant daylight.
- d. Automatic Full OFF: All lighting, including lighting connected to emergency circuits, shall be automatically shut off after 20 minutes of all occupants leaving the space. A control device meeting this requirement shall control the maximum space of 5000 ft<sup>2</sup>.
- e. Scheduled shutoff: All lighting in the space, including lighting connected to emergency circuits, shall be automatically shut off during periods when the space is scheduled to be unoccupied using either a time-of-day operated control device. The control device or system shall provide independent control sequences that (i) control the lighting for an area of maximum 25,000 ft<sup>2</sup> (ii) include only one floor and (iii) shall be programmed to account for weekends and holidays.

#### 10.4.1.2 Exceptions

The following lighting is not required to be on schedule shut off:

- i. Lighting in spaces where lighting is required for 24/7 continuous operation
- ii. Lighting in spaces where patient care is rendered.
- iii. Lighting in spaces where automatic shutoff would endanger the safety or security of the occupants.

- iv. Lighting load not exceeding 0.02 w/ft<sup>2</sup> multiplied by the gross lighted area of the building.

#### 10.4.1.3 *Parking Garage Lighting Control*

Lighting for parking garages shall comply with the following requirements:

- a. Parking garage lighting shall have automatic lighting shut off as per section 10.4.1.1.
- b. Lighting power of each luminaire shall be automatically reduced by a minimum of 50% where there is no activity detected within a lighting zone for 10 minutes. Lighting zone shall not be more than 3600 ft<sup>2</sup>

#### 10.4.1.4 *Special Applications*

Lighting controls specified in this section are only for equipment and applications mentioned in this section.

- 1. Lighting used for following applications shall be equipped with a local control independent of the control of general lighting. In addition, such lighting shall be controlled in accordance with the section 10.4.1.1 and section 10.4.1.1.
  - a. Display or accent lighting
  - b. Lighting in display cases
- 2. Guestrooms
  - a. All lighting and all switched receptacles in guestrooms and suites in hotels, motels, boarding houses or similar buildings shall be automatically controlled such that power to the lighting and switched receptacles in each enclosed space will be turned off within 10 minutes after all occupants leave that space.

#### 10.4.1.5 *Exception*

Enclosed spaces where the lighting and switched receptacles are controlled by card key controls and bathrooms are exempted.

Bathrooms shall have separate control device that shall turn off the lighting within 01 minute after all occupants have left the bathroom

- 3. Supplemental Task Lighting, including permanently installed undershelf or undercabinet lighting shall be controlled from
  - a. A control device integral to the luminaire
  - b. A local control independent of the control of general lighting
- 4. In addition, such lighting shall be controlled in accordance with Section 10.4.1.1 and section 10.4.1.1.

#### 10.4.1.6 *Exterior Lighting Control*

Lighting for exterior not exempted in Section 10.1 shall meet the following requirements

- a) Lighting shall be controlled by a device that automatically turns off the lights when sufficient daylight is available
- b) All building façade and landscape lighting shall be automatically shut off at midnight or business closing, whichever is later.
- c) Luminaires serving outdoor parking areas and access roads mounted in the poles shall be controlled to automatically reduce the power of each luminaire to 30% when no activity is detected for 15 minutes.

All time switches shall be capable of retaining programming and the time setting during loss of power for a period of at least 10 hours.

**10.4.2 Exterior Building Lighting Power**

The total exterior lighting power allowance for all exterior building applications is the sum of the base site allowance as mentioned in table 10.5.

For building exterior lighting applications specified in Table 10.5, the connected lighting power shall not exceed the specified lighting power limits specified for each of these applications.

Table 10-5. Exterior Building Lighting Power	
Area Description	Lighting Power Allowance
Parking area and driveways	0.08 W/ft <sup>2</sup>
Entry Canopies	0.20 W/ft <sup>2</sup>
Landscaping	0.04 W/ft <sup>2</sup>
Pedestrian and vehicular entrances and exits	21 W/lin ft of opening
Walkways less than 10 ft wide or greater	0.7 W/linear foot
Automated Teller Machines and night depositories	135 W per location plus 45 W per additional ATM per location
Drive-through windows/ doors	200 W per drive-through

For areas not listed in this table or are not comparable to areas listed in this table, use the comparable interior space type from table 10.5.

#### 10.4.2.1 Exceptions

Lighting used for the following exterior applications is exempted when equipped with an independent control device:

- a) Specialized signal, directional, and marker lighting associated with transportation;
- b) Lighting used to highlight features of public monuments and registered historic landmark structures or buildings;
- c) Lighting that is integral to advertising signage; or
- d) Lighting that is specifically designated as required by a health or life safety statute, ordinance, or regulation.
- e) Temporary lighting.
- f) Lighting for industrial production, material handling, and transportation sites, and associated storage areas.
- g) Lighting for athletic playing areas.
- h) Lighting integral to equipment or instrumentation and installed by its manufacturer.

#### 10.4.3 Dwelling Units

The lamps used in the buildings must comply with the relevant national standards as notified from time to time. Not less than 75% of permanently installed lighting fixtures shall use lamps with an efficacy of at least 75 lm/W. No other provisions of Section 7 apply to dwelling units.

### 10.5 BUILDING AREA METHOD COMPLIANCE PATH

Following method is to be used to determine the interior lighting power allowance by Building Area Method:

- a. Determine the appropriate building area type from table 10.6 and the corresponding LPD allowance. If the required building area type is not listed in the table, an equivalent area type may be selected.
- b. Determine the gross lighted floor area in ft<sup>2</sup> of the building area type
- c. Multiply the gross area determined in the last step by LPD

The interior lighting power allowance for the building is the sum of the lighting power allowances of all building area types. Trade-offs among building area types are permitted, provided that the total installed interior lighting power does not exceed the interior lighting power allowance.

Table 10-6. Interior LPD Building Area Method		
Sr. No	Common Space Type	LPD (W /ft <sup>2</sup> )
1	Automotive Facility	0.75
2	Convention Center	0.64
3	Court House	0.79
4	Dining: Bar Lounge/Leisure	0.8
5	Dining: Cafeteria/Fast Food	0.76
6	Dining: Family	0.71
7	Dormitory	0.53
8	Exercise Center	0.72
9	Gymnasium	0.76
10	Healthcare-Clinic	0.81
11	Hospital	0.96
12	Hotel	0.56
13	Library	0.83
14	Manufacturing Facility	0.82
15	Motel	0.56
16	Motion Picture Theater	0.44

Table 10-6. Interior LPD Building Area Method		
Sr. No	Common Space Type	LPD (W /ft <sup>2</sup> )
17	Multifamily	0.45
18	Museum	0.55
19	Office	0.64
20	Parking Garage	0.18
21	Penitentiary	0.69
22	Performing Arts Theater	0.84
23	Police/Fire Station	0.66
24	Post Office	0.65
25	Religious Building	0.67
26	Retail	0.84
27	School/University	0.72
28	Sports Arena	0.72
29	Town Hall	0.69
30	Transportation	0.5
31	Warehouse	0.45
32	Workshop	0.91

## 10.6 SPACE-BY-SPACE METHOD

Use the following steps to determine the interior lighting power allowance by the Space-by-Space Method:

- a. For each space enclosed by partitions that are 80% of the ceiling height or taller, determine the appropriate space type and the corresponding LPD allowance from Table 10.7. If a space has more than one functions, where more than one space type is applicable, that space shall be broken up into smaller subspaces, each using its own space type from table 10.7. If a subspace is smaller than 20% of the original space and less than 500 ft<sup>2</sup>, this space may not be broken out separately. Floor areas of balconies and other projections are to be included in the calculation.
- b. In calculating the area of each space and subspace, the limits of the area defined by the centerline of interior walls, the dividing line between the subspaces and the outside surface of exterior walls.
- c. Based on the space type selected for each space or subspace, determine the lighting power allowance of each space or subspace by multiplying the calculated area of the space or subspace by the appropriate LPD allowance determined in section 10.6.

The interior lighting power allowance is the sum of lighting power allowances of all spaces and subspaces. Trade-offs among spaces and subspaces are permitted, provided that the total installed interior lighting power does not exceed the interior lighting power allowance.

Table 10-7. Lighting Power Density Allowances					
Common Space Type	LPD Allowance (W/ft <sup>2</sup> )	Local Control	Automatic Daylight Control	Automatic Full OFF	Schedule Shut-off
Atrium					
< 20ft in height	0.39	REQ	-	REQ	REQ
≥ 20ft in height and ≤ 40 ft in height	0.48	REQ	-	REQ	REQ
≥ 40 ft in height	0.60	REQ	REQ	REQ	REQ
Audience Seating Area					
Auditorium	0.61	REQ	REQ	REQ	-
Gymnasium	0.23	REQ	REQ	REQ	REQ
Motion Picture Theater	0.27	REQ	-	REQ	-
Penitentiary	0.67	REQ	-	REQ	-
Performing Arts Theater	1.16	REQ	-	REQ	-
Religious Buildings	0.72	REQ	REQ	REQ	REQ
Sports Arena	0.33	REQ	REQ	REQ	-
All other Audience seating areas	0.23	REQ	REQ	REQ	-
Banking Activity Area	0.61	REQ	REQ	REQ	REQ
Classrooms/ lecture theatre halls/ training rooms	0.71	REQ	REQ	REQ	-
Conference/Meeting/Multipurpose	0.97	REQ	REQ	REQ	-
Confinement Cells	0.70	REQ	-	REQ	-
Copy/ Print Room	0.31	REQ	REQ	REQ	-
Corridors					
Facility for visually impaired (not used primarily by the staff)	0.71	REQ	-	REQ	-
Hospital	0.71	REQ	-	REQ	-
All other corridors	0.41	REQ	-	REQ	-
Courtrooms	1.20	REQ	REQ	REQ	REQ
Computer Room	0.94	REQ	REQ	-	REQ
Dining Areas					
Facility for visually impaired (not used primarily by the staff)	1.27	REQ	REQ	-	REQ
Bar Lounge/Leisure	0.86	REQ	REQ	-	REQ
Cafeteria/Fast Food	0.40	REQ	REQ	-	REQ
Family	0.60	REQ	REQ	-	REQ
All other Dining Areas	0.43	REQ	REQ	-	REQ
Electrical / Mechanical Room	0.43	REQ	REQ	-	REQ
Emergency Vehicle Garage	0.52	REQ	-	-	REQ
Food Preparation Area	1.09	REQ	-	REQ	REQ
Guest Room	0.41	REQ	-	-	REQ

Table 10-7. Lighting Power Density Allowances					
Common Space Type	LPD Allowance (W/ft <sup>2</sup> )	Local Control	Automatic Daylight Control	Automatic Full OFF	Schedule Shut-off
Laboratory					
In a classroom	1.11	REQ	REQ	-	-
All other laboratories	1.33	REQ	REQ	-	-
Laundry/ Washing Area	0.53	REQ	-	-	-
Loading Dock, interior	0.88	REQ	-	-	-
Lobby					
Facility for visually impaired (not used primarily by the staff)	1.69				
Elevator	0.65	REQ	-	REQ	-
Hotel	0.51	REQ	-	REQ	-
Motion Picture Theatre	0.23	REQ	-	-	-
Performing Arts Theater	1.25	REQ	-	-	-
All other Lobbies	0.84	REQ	-	REQ	-
Locker Room	0.52	REQ	-	-	-
Lounge/ Breakroom					
Healthcare Facility	0.42	REQ	REQ	REQ	-
All other lounges/ breakrooms	0.59	REQ	REQ	REQ	-
Office					
Enclosed and ≤ 250 ft <sup>2</sup>	0.74	REQ	-	REQ	-
Enclosed and > 250 ft <sup>2</sup>	0.66	REQ	REQ	-	-
Open Plan	0.61	REQ	REQ	-	-
Parking Area, Interior	0.15	REQ	-	REQ	-
Pharmacy Area	1.66	REQ	-	-	-
Restroom					
Facility for visually impaired (not used primarily by the staff)	1.26	REQ	-	-	-
All other restrooms	0.63	REQ	-	-	-
Sales Area	1.05	REQ	-	-	REQ
Seating Area, General	0.23	REQ	REQ	-	-
Storage Room					
< 50 ft <sup>2</sup>	0.51	REQ	-	-	REQ
≥ 50 ft <sup>2</sup>	0.38	REQ	-	-	REQ
Vehicular Maintenance Area	0.6	REQ	-	-	REQ
Workshop	1.26	REQ	-	-	REQ
Convention Center – Exhibit Space	0.61	REQ	-	-	REQ
Gymnasium/ Fitness Center					
Exercise Area	0.90	REQ	-	-	REQ
Playing Area	0.85	REQ	-	-	REQ

Table 10-7. Lighting Power Density Allowances					
Common Space Type	LPD Allowance (W/ft <sup>2</sup> )	Local Control	Automatic Daylight Control	Automatic Full OFF	Schedule Shut-off
Healthcare Facility					
Exam/ treatment room	1.40	REQ	-	-	-
Imaging Room	0.94	REQ	-	-	-
Medical Supply room	0.62	REQ	-	-	-
Nursery	0.92	REQ	-	-	-
Nurse's station	1.17	REQ	-	-	-
Operating room	2.26	REQ	-	-	-
Patient Room	0.68	REQ	-	-	-
Physical therapy room	0.91	REQ	-	-	-
Recovery room	1.25	REQ	REQ	-	-
Library					
Reading Area	0.96	REQ	REQ	-	-
Stacks	1.18	REQ	REQ	-	-
Manufacturing Facility					
Detailed Manufacturing area	0.80	REQ	-	-	REQ
Equipment room	0.76	REQ	-	-	REQ
Extra high bay area (>50 ft floor-to ceiling height)	1.42	REQ	-	-	REQ
High bay area (25 to 50 ft floor-to ceiling height)	1.24	REQ	-	-	REQ
Low bay area (<50 ft floor-to ceiling height)	0.86	REQ	-	-	REQ
Post Office – Sorting Area	0.76	REQ	-	-	REQ
Retail Facilities					
Dressing/fitting room	0.51	REQ	-	REQ	-
Mall concourse	0.82	REQ	-	-	REQ
Transportation Facility					
Baggage/carousel area	0.39	REQ	REQ	-	REQ
Airport concourse	0.25	REQ	REQ	-	REQ
Ticket counter	0.51	REQ	REQ	-	REQ

## 10.7 VERIFICATION, TESTING AND COMMISSIONING

### 10.7.1 Verification and Testing

Lighting control devices and systems shall be tested according to the guidelines formulated in Section 10.7.1 to verify that control devices are calibrated, adjusted, programmed and in working condition in accordance with manufacturer's recommendations. The following procedures shall be performed for the type of controls.

#### 10.7.1.1 Occupancy Sensors

- Certify that the Sensor has been located and aimed in accordance with manufacturer's recommendation.
- For Projects with up to Seven (07) Occupancy Sensors, all sensors shall be tested.



- c) For Projects with more than Seven (07) occupancy sensors, testing shall be performed for each unique combination of sensor type used and space geometry
  - i. For each sensor to be tested, verify the following:
    - a) Status indicator operates correctly.
    - b) Controlled lights turn OFF or down to the permitted level within the required time.
    - c) For auto-ON occupancy sensor, the lights turn ON when someone enters the space.
    - d) For manual-ON sensors the lights turn ON when manually activated.
    - e) The lights are not incorrectly turned ON by movement in nearby areas.

#### 10.71.2 Automatic Time Switches

The programming of Automatic Time Switches for weekday, weekend and off-day has to be verified.

1. Document for the owner automatic time-switch programming, including weekday, weekend, and holiday schedule.
2. Setting of time and date has to be set properly in the time switch.
3. In case of Battery backup, it has to be properly installed and energized.
4. Schedule for different time settings round the year has been maintained.
5. Simulate occupied conditions verify and document the following:
  - a) All lights can be turned ON and OFF by their respective switches.
  - b) The switch only operate lighting in the enclosed space in which the switch is located.
6. Simulate unoccupied conditions. Verify and document the following:
  - a) All nonexempt lights turn off
  - b) Manual override switch allows only the lights in the enclosed space where the override switch is located to turn on or remain on until the next scheduled shut off occurs.

#### 10.71.3 Daylight Controls

1. All control devices (photocontrols) have been properly located and field-calibrated, to set points and threshold light levels.
2. Daylight controlled lights adjust in response to available daylight.
3. The locations where calibration adjustments are made is readily accessible to authorized personnel.

## 10.8 COMPLIANCE DOCUMENTATION

Compliance documents should include plans, drawings, specifications, and other relevant documentation that demonstrate compliance with the relevant building codes and regulations. These documents should be submitted to the relevant authorities for review and approval.

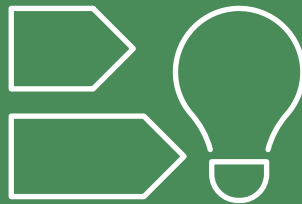

# 11

## ELECTRICAL POWER

Designing a building's electrical power system requires evaluating electrical load, selecting power sources like grids or renewables, and planning the distribution system. It involves sizing equipment (transformers, circuit breakers) and ensuring compliance with safety standards like the International Electrotechnical Commission. Emphasizing energy efficiency through efficient fixtures and renewables is key. Professional guidance from an electrical engineer ensures the system meets specific building needs and safety requirements.

## CHAPTER NO 11

# ELECTRICAL POWER

---

## 11.1 INTRODUCTION

Designing an electrical power system for a building requires careful consideration of various factors, such as the electrical load requirements, the available power sources, and the safety and regulatory requirements. Here are some general guidelines for designing an electrical power system for a building:

**Determine the electrical load requirements:** This involves identifying the electrical loads that will be connected to the power system, such as lighting, heating, air conditioning, and appliances. The electrical load requirements will help to determine the size and capacity of the electrical power system.

**Select the appropriate power sources:** The power sources for the electrical power system can include the utility grid, backup generators, solar panels, and wind turbines. The selection of the power sources will depend on various factors, such as the location of the building, the availability of power sources, and the cost.

**Determine the required electrical distribution system:** The electrical distribution system will depend on the size and complexity of the building. For small buildings, a simple radial distribution system may be sufficient, while larger buildings may require a more complex distribution system, such as a ring or grid system.

**Size and selection the electrical equipment:** This involves sizing and selecting the electrical equipment, such as transformers, switchgear, circuit breakers, and cables, based on the electrical load requirements and the electrical distribution system.

**Ensure compliance with safety and regulatory requirements:** The electrical power system design must comply with the International Electrotechnical Commission (IEC) or any other adopted standards. This includes ensuring proper grounding, protection against electrical shock, and protection against overcurrent and short circuits.

**Energy efficiency:** Energy efficiency should be considered in the design of the electrical power system. This can include the use of energy-efficient lighting and appliances, the optimization of the electrical load requirements, and the incorporation of renewable energy sources.

These are some general guidelines for designing an electrical power system for a building. It's important to work with a qualified electrical engineer or technician to ensure that the design meets the specific requirements of the building and complies with all safety and regulatory requirements.

## 11.2 NECESSARY REQUIREMENTS

### 11.2.1 Cable Size

Cable sizing is a critical aspect of electrical design for buildings, and it is essential to adhere to standard requirements to ensure compliance with electrical energy building codes. The following points outline the standard requirements for cable sizing in the context of electrical energy building codes.

- a. The cable must be sized to carry the expected current without exceeding its maximum allowable temperature. This involves considering various factors, including the expected load, ambient temperature, cable installation conditions, and other factors that may affect the cable's performance. For different type of insulation material, the maximum admissible temperature is given in Table 11.1. Source: **(table 52.1 of IEC 60364-5-52).**

Table 11-1. Maximum Operating Temperatures for Types of Insulation		
Sr. No	Type of insulation	Temperature limit °C
1	Polyvinyl-chloride (PVC)	70 at the conductor
2	Cross-linked polyethylene (XLPE) and ethylene propylene rubber (EPR)	90 at the conductor
3	Mineral (PVC covered or bare exposed to touch)	70 at the sheath
4	Mineral (bare not exposed to touch and not in contact with combustible material)	105 at the sheath

- b. The cable should be sized to minimize voltage drop. IEC 60364-5-52 in Annex G states that the voltage drop between the origin of an installation and any load point should not be greater than the values in Table 11.2 expressed with respect to the value of the nominal voltage of the installation.

Table 11-2. Voltage Drop Limits		
Type of installation	Lighting %	Other uses %
A - Low voltage installations supplied directly from a public low voltage distribution system	3	5
B - Low voltage installation supplied from private LV supply <sup>a</sup>	6	8
<p><sup>a</sup> as far as possible, it is recommended that voltage drop within the final circuits do not exceed those indicated in installation type A.</p> <p>When the main wiring systems of the installations are longer than 100 m, these voltage drops may be increased by 0,005 % per meter of wiring system beyond 100 m, without this supplement being greater than 0,5 %.</p> <p>Voltage drop is determined from the demand by the current-using equipment, applying diversity factors where applicable. Or from the values of the design current of the circuits.</p>		

- a. The cable should be able to withstand the short circuit current without sustaining damage. This requires consideration of the expected fault current, cable type, insulation, and other factors that may impact the cable's performance in case of a fault. All electric utility companies must define and provide the short circuit MVA rating to the design engineer via some online portal or through an app without any cost.
- b. The cable should be able to withstand thermal stresses without exceeding its maximum allowable temperature. This requires consideration of the expected operating conditions, cable type, insulation, and other factors that may impact the cable's performance.
- c. The cable should be installed in accordance with IEC-60364 standards. This includes requirements for cable routing, support, protection, and termination. In selecting cable sizes for buildings, it is essential to consider de-rating factors that can affect the cables' performance. De-rating factors are factors used to adjust the current-carrying capacity of a cable based on various environmental and installation conditions. These factors are necessary because the current carrying capacity of a cable is dependent on several factors, including its size, insulation type, ambient temperature, and installation conditions. Failure to consider these factors can lead to issues such as overheating of cables, voltage drop, and possible electrical hazards.

The current-carrying capacity of three-phase, 4-core or 5-core cables is based on the assumption that only 3 conductors are fully loaded. However, when harmonic currents are circulating, the neutral current can be significant, and even higher than the phase currents. This is due to the fact that the 3<sup>rd</sup> harmonic currents of the three phases do not cancel each other and sum up in the neutral conductor. This of course affects the current-carrying capacity of the cable, and a correction factor shall be applied. IEC 60364-5-52 standard defines the factors to cater the effect of harmonic current for cables. These factors can be seen in Table 11.3.

Table 11-3. Reduction Factors for Harmonics Currents in Four Core and Five Core Cables		
Third harmonic content of phase current	Reduction factor	
	Size selection is based on phase current	Size selection is based on neutral current
%		
0-15	1.0	-
15 - 33	0.86	-
33 - 45	-	0.86
> 45	-	1.0

### 11.2.2 Conserve Electricity

There are many things that can be done to conserve electrical energy in a building. Here are some examples:

- a. Use energy-efficient lighting: Replace incandescent light bulbs with LED bulbs, which use less energy and last longer as mentioned in chapter 10 of this code.
- b. Install programmable thermostats: Programmable thermostats allow you to set the temperature of your building based on occupancy patterns, reducing energy usage when the building is unoccupied (refer to chapter 8 of this code).
- c. Upgrade HVAC systems: Upgrade your heating, ventilation, and air conditioning (HVAC) systems to more energy-efficient models and have them regularly serviced to ensure they are operating at peak efficiency (refer to chapter 8 of this code).
- d. Use natural light: Make use of natural light by installing skylights or windows and use reflective surfaces to direct natural light deeper into the building (refer to chapter 5 of this code).
- e. Install solar panels: Install solar panels on the roof of your building to generate clean energy and reduce your dependence on the grid (refer to chapter 14 of this code).
- f. Install motion sensors: For requirements regarding motion sensors refer Chapter on “Lighting” of this code.
- g. Use energy-efficient appliances: Replace inefficient appliances including fans, refrigerators, motors, air conditioners etc. with energy efficient appliances.
- h. Educate building occupants: Educate building occupants on ways to conserve energy, such as turning off lights and electronics when not in use and encouraging the use of stairs instead of elevators.

These are just a few examples of the many ways that energy can be conserved in a building. By making these changes, building owners and occupants can reduce their energy bills and help to reduce the environmental impact of their building.

### 11.2.3 Transformers

Transformer efficiency is an important factor in minimizing energy losses in power distribution systems. For distribution transformers, the minimum efficiency requirements must be in compliance to the relevant national standards as notified from time to time. All measurement of losses shall be carried out by certified persons by using calibrated digital meters of class 0.5 or better accuracy. All transformers of capacity of 500 kVA and above would be equipped with additional local or remote metering class current transformers (CTs) and potential transformers (PTs) additional to requirements of Utilities so that periodic loss monitoring study may be carried out.

#### 11.2.4 Energy Efficient Motors

The motors used in the buildings must, comply with the relevant national standards as notified from time to time.

#### 11.2.5 Power Factor Correction

Power factor correction is an important aspect of energy efficiency in buildings. A low power factor can result in increased electricity consumption and higher electricity bills, as well as increased wear and tear on electrical equipment. All electricity supplies exceeding rating of 100 A per phase, shall maintain their power factor between 0.90 lag and unity at the point of connection.

#### 11.2.6 Power Distribution Systems Losses

The power cabling shall be adequately sized as to maintain the distribution losses less than 1% of the total power usage. Record of design calculation for the losses should be maintained.

#### 11.2.7 Availability of Back-up Power Sources

The availability of power sources in building codes refers to the requirement that buildings must have a reliable and consistent supply of electrical power to meet the needs of their occupants. This includes provisions for backup power in case of emergencies or power outages, as well as requirements for the quality and stability of the electrical supply.

The necessary minimum number of power sources required for a given building or occupancy type can vary depending on several factors, including the size and type of the building, the electrical demand, and the criticality of the loads. A minimum of two power sources for certain critical loads, such as emergency lighting, fire pumps, and life safety systems are required. The electrical infrastructure be installed and maintained in accordance with applicable codes and standards to ensure the safety and reliability of the system. The selection of multiple power sources and their grid synchronization must be as per the standards.

#### 11.2.8 Renewable Power Sources

Renewable energy sources are a way to promote sustainability and reduce carbon emissions. Some common examples of renewable energy sources are solar panels, wind turbines, geothermal systems, and hydropower. The minimum encouraging requirement for renewable energy sources is the maximum sanctioned load of the system for new construction or renovations. However, the maximum allowable renewable sources could be as per the local net-metering policy. The use of renewable energy sources in building codes can help promote the growth of the renewable energy industry, reduce dependence on fossil fuels, and contribute to the fight against climate change. For further details please refer to Chapter 11 “Renewable Energy”

### 11.3 COMPLIANCE DOCUMENTATION

Compliance documents should include plans, drawings, specifications, and other relevant documentation that demonstrate compliance with the relevant building codes and regulations. These documents should be submitted to the relevant authorities for review and approval.

- a. All the design and safety compliance must be passed from the electrical consultant or electrical power system engineers (Professional Engineer) with certain minimum industrial exposure.
- b. All the results must be verified after the site verification and testing from the local firms.
- c. The completion certificate could be issued after the site verification and testing from the local firms.
- d. Building codes can be enforced through education and outreach efforts to promote awareness and understanding of the code among contractors, builders, and the public.



# 12

## MONITORING DEVICES

The building should be equipped to measure energy input and output from various sources like electricity, fuel, and water, using accurate instruments and reliable supplier information. Data monitoring over at least the past three years should be archived electronically or on paper. Regular calibration and cross-verification of monitoring instruments are crucial to maintain data accuracy.

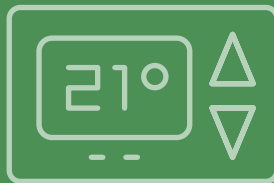

## CHAPTER NO 12

# MONITORING DEVICES

---

## 12.1 INTRODUCTION

The building should have provision for quantifying energy input & output of different sources such as electricity, fuel, and water. The quantification is to be based on adequate measurements through instruments of acceptable accuracy and credible information from energy suppliers. The monitored data of at least previous 3 years is required to be archived in electronic or paper form. Calibration of the monitoring instruments and cross-verification of the recorded data is essential to ensure accuracy of monitoring data.

## 12.2 MONITORING OF ELECTRICITY CONSUMPTION

Following parameters are mandatory to be monitored at least monthly. The monitoring is to be done by installing permanently fixed meter (instrument).

1. Total electricity **kWh** consumption by the building
2. Average Power Factor of the building

Additional meters can be installed based on physical sections (e.g., story), type of load, and time of utilization in order to perform analysis of electricity consumption.

Multi-story buildings are required to quantify total electricity consumption (kWh), and average power factor of each story at least on monthly basis through permanently fixed meter(s) / instrument(s).

Electrical wiring of the building should enable easy and quick monitoring through permanent or portable meter(s) / instrument(s) of electricity consumption by type of load e.g., HVAC Load, Fan Load, Lighting Load, Water Heating Load, Motors Load, Plug Load, etc.

Followings are required to have permanently installed dedicated energy metering:

1. Each charging point for electric vehicle
2. Swimming pool plant (pump sets, water filtration, etc.)
3. Continuous & Emergency Duty infrastructure such as Information Technology (IT) & Security systems, emergency lighting, firefighting, etc.
4. Electricity consumed and supplied by UPS of capacity 2000 VA or higher
5. Each elevator
6. Each escalator

### 12.3 MONITORING OF ELECTRICITY SUPPLY FROM VARIOUS SOURCES

A building having multiple sources of electricity supply should be able to quantify electricity supplied from each source.

Electricity **kWh** supplied from each off-grid solar electricity system should be monitored preferably on daily (at least on weekly) basis.

### 12.4 NET METERING

In case of Net Metering (import / export meter), monitoring of electricity import and export is to be done on daily basis.

### 12.5 MONITORING OF GENERATOR SET

Electricity supplied and fuel consumed by each generator set (genset) should be monitored in order to determine efficiency of individual genset.

Date and time of start and stop, and reason for operation of each genset should be recorded. The electricity **kWh** supplied by the genset should be preferably measured by meter(s) / instrument(s). In case the genset has provision to measure only the electrical power **kW**, then average power supplied is to be estimated by recording values of instantaneous power at appropriate intervals (the maximum interval can be of 30 minutes).

Fuel (oil / gas) consumed by individual genset during each operation is to be recorded in order to calculate the consumed energy. Calorific values of fuel can be determined through laboratory test or credible information from supplier of the fuel. In case, instrumentation is available to measure only flow rate or mass rate of the fuel, then average fuel consumed is to be estimated by recording values of instantaneous rate at appropriate intervals (the maximum interval can be of 30 minutes).

For gensets of 500 kVA and higher capacity, following additional parameters are to be monitored.

- a. Exhaust gas temperature & pressure on hourly basis.
- b. Electricity consumption by auxiliary load of the genset.

### 12.6 MONITORING OF NATURAL GAS CONSUMPTION

Total gas consumption by the building is mandatory to be monitored at least monthly. The monitoring is to be done by installing permanently fixed meter (instrument). Calorific values of fuel can be determined through laboratory test or credible information from supplier of the fuel.

1. Additional meters can be installed based on physical sections (e.g. story), and type of load in order to perform analysis of gas consumption.

2. Multi-story buildings are required to quantify total gas consumption of each story at least on monthly basis through permanently fixed meter(s) / instrument(s).
3. Gas piping network of the building should enable easy and quick monitoring – through permanent or portable meter(s) / instrument(s) – of gas consumption by type of load e.g., Water Heaters, Space Heaters, Boilers / Chillers, Stoves, etc.
4. Similarly, quantity of LPG cylinders consumed by the building should be recorded on monthly basis.

## 12.7 MONITORING OF BOILERS

Steam supplied and fuel consumed by each boiler should be monitored in order to determine efficiency of individual boiler. Following parameters are to be monitored:

1. Date and time of start and stop of each boiler
2. Temperature of steam
3. Pressure of steam
4. Quantity of steam supplied by the boiler should be preferably measured by meter(s) / instrument(s). In case the boiler has provision to measure only flow rate or mass rate of steam, then average steam supplied is to be estimated by recording values of instantaneous flow at appropriate intervals (the maximum interval can be of 1 hour).
5. Quantity, Temperature, and Pressure of feed water
6. Fuel (oil / gas) consumed by individual boiler during each operation is to be recorded in order to calculate the consumed energy. Calorific values of fuel can be determined through laboratory test or credible information from supplier of the fuel. In case, instrumentation is available to measure only flow rate or mass rate of the fuel, then average fuel consumed is to be estimated by recording values of instantaneous rate at appropriate intervals (the maximum interval can be of 1 hour).
7. Flue gas temperature & pressure on hourly basis.
8. Electricity consumption by auxiliary system of the boilers.

## 12.8 MONITORING OF WATER CONSUMPTION

1. Total water consumption by the building is mandatory to be monitored at least monthly. The monitoring is to be done by installing permanently fixed meter (instrument).
2. Additional meters can be installed based on physical sections (e.g. story), and type of load in order to perform analysis of water consumption.
3. Multi-story buildings are required to quantify total water consumption of each story at least on monthly basis through permanently fixed meter(s) / instrument(s).
4. Water piping network of the building should enable easy and quick monitoring – through permanent or portable meter(s) / instrument(s) – to perform consumption analysis.
5. Swimming pools are required to have permanently installed dedicated meters to determine consumption of water.

## 12.9 MONITORING OF WATER SUPPLY FROM VARIOUS SOURCES

A building having multiple sources of water supply should be able to quantify water supplied from each source.

## 12.10 MONITORING OF UNDERGROUND WATER EXTRACTION PUMP SET

Water supplied and electricity consumed by each underground (sub-soil) water extraction pump set should be monitored in order to determine efficiency of individual pump set.



# 13

## GEOTHERMAL ENERGY

Geothermal energy, a renewable and sustainable resource, harnesses Earth's internal heat. It consists of shallow geothermal energy for heating and cooling at depths up to 400 meters, and deep geothermal energy below 400 meters for electricity generation and industrial heating, both of which remain underexploited in Pakistan.

## CHAPTER NO 13

# GEOTHERMAL ENERGY

---

## 13.1 INTRODUCTION

Geothermal energy refers to the heat energy that is generated and stored beneath the Earth's surface. It is a renewable and sustainable form of energy that harnesses the heat from the Earth's core and transfers it to generate electricity or for direct use in heating and cooling systems. Geo (earth) + thermal (heat) can be broadly divided into two categories. The first one is shallow geothermal has a depth ranging from 1.5 m to 400 m. This band of earth is suited for storing or retrieving energy for climate control applications both heating and cooling as the temperature remains constant throughout the year equivalent to the annual surface mean temperature (21°C-27°C).

While the second one is deep geothermal. At the depth below 400 m the temperature of the earth starts to increase at the rate of around 1°C per 80 ft, this is also known as the geothermal gradient and can vary according to geological morphology. Temperature at these depths is suitable for electricity production through steam turbines and other industrial heating applications. Both forms of geothermal energy are an untapped resource in Pakistan.

## 13.2 SCOPE

### 13.2.1 Applicable Building Systems

Geothermal technology can be applied to various building systems, including heating, ventilation, and air conditioning (HVAC) systems, domestic hot water systems, and swimming pool heating systems.

### 13.2.2 Exemptions

The geothermal technique may only be economically feasible for new constructions. The decision to adopt this technology remains solely dependent on the stakeholders. Considering both building safety and economy, old buildings are exempt from utilizing geothermal energy for their heating and cooling needs though in certain cases retrofitting of already installed HVAC systems with geothermal systems is possible depending on availability of land for the geo field.

### **13.2.3 Limitations**

This chapter is limited to the available literature on geothermal technology in buildings construction for the purpose of energy efficiency in Pakistan. The chapter is not intended to be a comprehensive guide on geothermal technology in buildings construction, and readers are encouraged to seek additional information from relevant sources.

## **13.3 ADMINISTRATION AND ENFORCEMENT**

### **13.3.1 Administration and Enforcement**

To encourage the usage of geothermal technology in building construction for the purpose of energy efficiency, it is important to establish an effective administration and enforcement framework. This framework should aim to ensure that all building projects comply with the relevant standards and guidelines.

### **13.3.2 Compliance Requirements**

To ensure compliance with the relevant standards and guidelines, the following mandatory requirements should be in place:

### **13.3.3 Mandatory Requirements**

All new buildings and building alterations must meet the minimum requirements for energy efficiency as outlined in the relevant building codes and regulations.

### **13.3.4 New Buildings**

For new buildings, the usage of geothermal technology for heating, cooling, and hot water should be considered as a mandatory requirement. The design and installation of the geothermal system should be carried out by licensed professionals (license to be issued by AEDB similar to PV experts/Vendors) with expertise in geothermal technology.

### **13.3.5 Alterations to Existing Buildings**

For alterations to existing buildings, the following areas should be considered for the usage of geothermal technology:

#### **13.3.5.1 Building Envelop**

The building envelop should be evaluated before the installation of the geothermal system in the existing building for the opportunities to improve the energy efficiency of the building. This may include the installation of building insulation, weatherstripping, and the replacement of the windows and doors with more energy efficient options like windows with Aluminum or Metal Frames, Composite Frames, Fiberglass Frames, Vinyl Frames, Wood Frames, Glazed window glass, Low-Emissivity Coatings on window glass, Spectrally Selective Coatings, Gas Fills and Spacers, and doors like steel skin with a polyurethane foam insulation core, steel and fiberglass-clad, Single-pane glass or “patio” doors.



### **13.3.5.2 Heating, Ventilation and Air Conditioning**

The heating, ventilation, and air conditioning (HVAC) systems should be evaluated for opportunities to improve energy efficiency. This may include the installation of geothermal heat pumps for heating and cooling.

### **13.3.5.3 Service Water Heating**

The service water heating system should be evaluated for opportunities to improve energy efficiency. This may include the installation of geothermal heat pumps for hot water.

### **13.3.6 Capacity Building**

The administrative requirements for compliance should include the establishment of a geothermal technology program for professionals and contractors involved in the design and installation of geothermal systems by National Energy Efficiency and Conservation Authority (NEECA) or Alternative Energy Development Board (AEDB). This program should ensure that all professionals and contractors are adequately trained in the design and installation of geothermal systems.

### **13.3.7 Compliance Documents**

Compliance documents should include plans, drawings, specifications, and other relevant documentation that demonstrate compliance with the relevant building codes and regulations. These documents should be submitted to the relevant development authorities for review and approval.

### **13.3.8 Supplementary Information and Awareness**

Supplementary information should be provided to building owners and occupants to promote the benefits of geothermal technology and encourage its usage. This may include information on energy savings, environmental benefits, and available incentives and financing options. Collaboration with international organizations and countries that have extensive experience in geothermal technology can also help promote its usage in Pakistan.

## **13.4 GEOTHERMAL TECHNOLOGY IN BUILDINGS CONSTRUCTION**

### **13.4.1 Design Considerations for Geothermal Systems**

#### **13.4.1.1 Site Selection**

The first step in designing a geothermal system is selecting the most suitable site. The site should have access to a geothermal resource: Clay, Sand, Silt is acceptable. Rock formations/terrains may not be suitable. sufficient space for drilling and installation of the necessary components. Factors such as soil type, groundwater level, and seismic activity should also be considered to ensure the stability and durability of the system.

### 13.4.2 Building Design

The building design also plays a crucial role in the success of a geothermal system. The building should be well-insulated to minimize heat loss or gain, reducing the heating and cooling load required from the system. Orientation and shading of windows and walls can also affect the energy efficiency of the building. Building Designers should also consider the climatic conditions, regional conditions and integration of the geothermal system with the other building systems, such as ventilation and air conditioning. Moreover, Geothermal technology can be used in various types of buildings, including residential, commercial, and industrial buildings. It is a versatile technology that can be used for both heating and cooling purposes, and it can be adapted to different building sizes and designs.

- a. **In residential buildings**, geothermal technology can be used to provide space heating, space cooling, and hot water. Geothermal heat pumps can be installed in new or existing homes, and they are often used in conjunction with radiant floor heating systems for maximum efficiency and comfort.
- b. **In commercial buildings**, geothermal technology can be used for a wide range of applications, including space heating and cooling, hot water production, and process heating and cooling. Large-scale geothermal systems can be used to heat and cool buildings such as schools, hospitals, and office buildings, while smaller systems can be used in retail stores and restaurants.
- c. **In industrial buildings**, geothermal technology can be used for process heating and cooling, as well as space heating and cooling. Industrial applications of geothermal technology include food processing, greenhouse heating, and mining operations.

### 13.5 GUIDELINES FOR SYSTEM SIZING AND PLACEMENT

The size of the geothermal system should be carefully calculated to meet the specific heating and cooling needs of the building. Oversized or undersized systems can result in inefficiencies and higher operating costs. Factors such as the building's size, insulation, and orientation, as well as the local climate, should be taken into account when sizing the system.

#### 13.5.1 Building Size

When referring to buildings in the context of geothermal systems, “oversized” and “undersized” typically refer to the capacity of the geothermal system relative to the heating and cooling load of the building. An “oversized” geothermal system is one that is designed to provide more heating and cooling capacity than is actually needed by the building. This can result in inefficient operation, as the system may have to cycle on and off frequently or may not operate at its full capacity for extended periods of time.

On the other hand, an “undersized” geothermal system is one that is not able to provide enough heating and cooling capacity to meet the demands of the building. This can result in discomfort for occupants, as well as increased energy consumption as the system struggles to keep up with the load. Proper sizing of a

geothermal system is important to ensure optimal performance and efficiency. This requires a thorough analysis of factors such as the local climate conditions, building orientation, thermal envelope, and building insulation.

### 13.5.1.1 Building's Total Heat Loss or Gain Calculation

To calculate a building's total heat loss or gain, you can use the following formula:

$$Q = U \times A \times \Delta T \quad (\text{Eqn 13-1})$$

Where:

Q = the building's total heat loss or gain in Btu/h (British thermal units per hour) U = the overall heat transfer coefficient in Btu/(h × ft<sup>2</sup> × °F)

A = the building's total surface area in ft<sup>2</sup>

ΔT = the temperature difference between inside and outside air in °F

To determine U, you will need to calculate the individual heat transfer coefficients (U-values) for each component of the building's envelope (walls, roof, windows, doors, etc.) and combine them using a weighted average. The U-value represents the rate of heat transfer through a specific component and is expressed in Btu/(h × ft<sup>2</sup> × °F).

The following formula to determine the overall U-value for the building:

$$U = \Sigma(U_i \times A_i)/A \quad (\text{Eqn 13-2})$$

Where:

U<sub>i</sub> = the U-value for component i in Btu/(h × ft<sup>2</sup> × °F)

A<sub>i</sub> = the surface area of component i in ft<sup>2</sup>

A = the total surface area of the building's envelope in ft<sup>2</sup>

For instance, the U-factor (U<sub>i</sub>) for a window can be calculated using the following formula:

$$U_i = 1 / (R_w + R_f + R_{sp} + R_a) \quad (\text{Eqn 13-3})$$

Where:

R<sub>w</sub>: Resistance of the window frame

R<sub>f</sub>: Resistance of the window glazing or pane

R<sub>sp</sub>: Resistance of the window spacer

R<sub>a</sub>: Resistance of the air film inside the building and outside the building

The values for R<sub>w</sub>, R<sub>f</sub>, and R<sub>sp</sub> can be obtained from the window manufacturer. The value for R<sub>a</sub> is typically calculated using standard values based on the indoor and outdoor temperatures and wind speed. Once the U-factor is calculated, it can be used to determine the overall thermal performance of the window. A lower U-factor indicates better insulation and energy efficiency. It's important to note that this is a simplified explanation of the calculation process,

and there may be additional factors to consider depending on the specific building and location. It is recommended to consult with a professional engineer or energy auditor to accurately calculate the building's heat loss or gain.

#### 13.5.1.2 Btu/h to kWh conversion

To convert the consumption of a geothermal system from Btu/h to kWh, you can use the following formula:

$$\text{kWh} = \text{Btu/h} \div 3,412 \quad (\text{Eqn 13-4})$$

Where 3,412 is a conversion factor that represents the number of Btu per kWh.

For example, if a geothermal system has a heating capacity of 60,000 Btu/h, the energy consumption in kWh would be:

$$\text{kWh} = 60,000 \text{ Btu/h} \div 3,412 = 17.6 \text{ kWh/h} \quad (\text{Eqn 13-5})$$

Therefore, the geothermal system would consume approximately 17.6 kWh of energy per hour when operating at its maximum heating capacity of 60,000 Btu/h.

#### 13.5.2 Determine the Heat Load of Building

The first step in sizing a geothermal system is to determine the heat load of the building, which is the amount of heating or cooling needed to maintain a comfortable indoor environment. This can be calculated based on factors such as the size and shape of the building, the insulation level, the number of occupants, and the type of equipment used.

#### 13.5.3 Consider the Climate and Soil Conditions

The next step is to consider the climate and soil conditions at the site. The soil and climate conditions of a particular area play a crucial role in determining the feasibility of a geothermal system for a building. The following factors should be considered:

- i. **Soil Type:** The type of soil on the site affects the thermal conductivity of the ground. Soils with high thermal conductivity, such as sand and gravel, are ideal for geothermal systems because they transfer heat more efficiently. Conversely, soils with low thermal conductivity, such as clay, can reduce the efficiency of the system.
- ii. **Groundwater Availability:** The availability of groundwater affects the efficiency of the system. A higher volume of groundwater (10-250 m<sup>3</sup>/h) with 100-500 ft depth of ground water table in the building area can improve heat transfer, making the system more efficient.
- iii. **Climate:** The climate of the area is a crucial factor in determining the feasibility of a geothermal system. Regions with extreme temperatures or weather patterns may require additional heating or cooling, which can impact the efficiency and effectiveness of the system.

- iv. **Surface Topography:** The topography of the site can impact the installation of the geothermal system. Steep slopes, for example, may make it difficult to install the necessary piping, while flat surfaces are ideal.
- v. **Vegetation:** The presence of trees or other vegetation can impact the installation and effectiveness of a geothermal system. Trees can interfere with the piping system and cause damage, while open areas are ideal for installation.

To consider these factors, a site-specific feasibility study should be conducted before the installation of a geothermal system. This study will assess the soil and climate conditions of the area and provide recommendations for the most effective geothermal system design.

#### **13.5.3.1 Determine the System Type**

There are different types of geothermal systems, including closed-loop systems and open-loop systems. Closed-loop systems are generally more common, as they do not require a constant supply of water and are less susceptible to contamination. Open-loop systems can be more efficient in some cases, but require a reliable supply of clean water. Horizontal system is generally cheaper to deploy per require at least 600 sq ft of open space per ton available, if lesser open area is available vertical systems are required.

#### **13.5.3.2 Size the Loop Field**

Once the heat load and system type have been determined, the size of the loop field can be calculated. This will depend on factors such as the heat load of the building, the thermal conductivity of the soil, and the type of loop configuration to be used. The loop field should be sized to provide enough heating or cooling capacity to meet the needs of the building.

#### **13.5.3.3 Determine the Placement of Loop Field**

A ground loop is a series of pipes buried underground at a depth where temperatures stay consistent year-round. It serves as the critical link allowing geothermal heat pumps to use the earth as a heat source or heat sink, depending on if heating or cooling is required. The placement of the loop field is also an important consideration. It should be located in an area that is accessible for installation and maintenance, but also protected from damage or disturbance. The depth of the loop field will also depend on the soil conditions and the required heating or cooling capacity.

#### **13.5.3.4 Cost Effectiveness**

The final consideration is the economics of the system. While geothermal systems can be more expensive to install than conventional HVAC systems, they can also provide significant long-term cost savings. Factors to consider include the cost of energy in the area, the expected lifespan of the system, and the available incentives or rebates in that particular area/region.

Geothermal systems have been shown to be cost-effective over the long term. While the initial installation costs can be higher than conventional heating

and cooling systems, the reduced operating costs and energy savings over the life of the system can make up for the initial investment. According to the US Environmental Protection Agency (EPA), the cost savings from a geothermal system can vary depending on factors such as local climate, energy prices, and the size and type of the building. However, the EPA estimates that homeowners can save up to 30% on heating costs and 50% on cooling costs compared to conventional systems. In addition, the US Department of Energy estimates that a geothermal system can pay for itself within 5 to 10 years of installation through energy cost savings. Several case studies have demonstrated the cost effectiveness of geothermal systems in buildings. For example, the Discovery Elementary School in Virginia, USA, chaptered a 50% reduction in energy consumption and cost savings of \$11,000 per year after installing a geothermal system for heating and cooling.

### 13.5.4 Piping Design and Fluids

#### 13.5.4.1 Piping Design

The type of pipes used in geothermal technology depends on several factors, such as the temperature and pressure of the geothermal fluid, the specific application of the geothermal system, and the geological conditions of the site. The amount of pipe required for a geothermal system depends on several factors, such as the size of the building, the heat load, and the type of geothermal system being installed. However, as a general rule of thumb, a typical horizontal loop system requires between 400 to 600 feet of pipe per ton of heating and cooling capacity. For a vertical loop system, the amount of pipe required will depend on the depth of the borehole and the geological conditions at the site. Typically, vertical loop systems require between 150 to 200 feet of pipe per ton of heating and cooling capacity.

In general, two types of pipes are commonly used in geothermal systems: **high-density polyethylene (HDPE) pipes** and **cross-linked polyethylene (PEX) pipes**. Both of these materials are highly resistant to corrosion and have good thermal properties, making them suitable for use in geothermal systems.

- i. HDPE pipes are commonly used in vertical borehole systems, where they are inserted into the borehole and connected to a horizontal pipe loop at the bottom of the hole. These pipes are highly durable and can withstand high temperatures and pressures, making them suitable for use in deep boreholes. Thermal conductivity greater than 0.48W/mK is desirable.
- ii. PEX pipes, on the other hand, are typically used in horizontal pipe loops or in shallow trench systems. They are more flexible than HDPE pipes, which allows them to be easily installed in a variety of configurations. PEX pipes are also less expensive than HDPE pipes, which can make them a more cost-effective option for some applications.

In addition to HDPE and PEX pipes, other materials such as copper, steel, and polypropylene may also be used in geothermal systems, depending on the specific requirements of the project. It is important to select the appropriate pipe material and size for the geothermal system to ensure optimal performance and

longevity. Generally,  $\frac{3}{4}$ " Pipe The  $\frac{3}{4}$ " pipe is the most commonly used size for geothermal installations. It is available in 600 ft coils.  $1\frac{1}{4}$ " Pipe The  $1\frac{1}{4}$ " pipe can be used in the same types of geothermal installations as the  $\frac{3}{4}$ " pipe. It is available in 500 ft coils. While A closed ground loop system consists of a series of high-density polyethylene pipes buried in your yard. A heat transfer fluid, comprised of antifreeze and water, is inside the ground loop pipes. The piping design of a geothermal system is critical to its overall performance and efficiency. In a closed-loop system, the piping must be buried underground and designed to minimize heat loss or gain. The pipe material must be resistant to corrosion and able to withstand the high temperatures and pressures involved in the system. In an open-loop system, the piping design must allow for the flow of hot water from the geothermal source to the heat exchanger and back to the source without contamination or loss of heat.

#### 13.5.4.2 Fluid details

Geothermal technology uses different types of fluids, depending on the specific application and the temperature range of the geothermal resource. There are two commonly used types of fluids that can be circulated through the ground loop system. The Standard Geothermal uses a mix of water, antifreeze (Propylene Glycol), and refrigerant. While, the Waterless Geothermal System uses R-410A refrigerant. The fluid used in geothermal systems is typically water-based, but it may also contain various additives or chemicals to improve performance or prevent corrosion.

- a. For low-temperature geothermal systems, such as those used for space heating and cooling, water or water-based solutions such as propylene glycol are commonly used as the heat transfer fluid. These solutions are circulated through the ground loop to absorb or release heat from the ground, depending on the heating or cooling needs of the building.
- b. For high-temperature geothermal systems, such as those used for power generation, a binary fluid system is often used. This system consists of two fluids, one of which is typically a low-boiling-point organic fluid such as isobutane or pentane, which is vaporized by the heat from the geothermal resource. The vapor then drives a turbine to generate electricity. The second fluid in the system is typically water, which is used to cool and condense the vapor back into a liquid.

In some cases, geothermal fluids may also contain dissolved minerals, such as calcium, magnesium, and silica. These minerals can cause scaling or fouling of the heat transfer surfaces in the geothermal system, which can reduce the system's efficiency and lifespan. In these cases, water treatment or other measures may be needed to mitigate the effects of mineral scaling and fouling.

The design considerations for geothermal systems in buildings construction are critical to the success of the system in terms of performance and efficiency. By carefully selecting the site, designing the building for energy efficiency, sizing the system appropriately, and designing the piping system for optimal performance, designers and builders can ensure that geothermal technology provides a cost-effective and sustainable solution for heating, cooling, and hot water in buildings.

### **13.5.5 Applications of Geothermal Technology in Buildings Construction**

#### **13.5.5.1 Heating and Cooling**

One of the primary applications of geothermal technology in buildings construction is heating and cooling. Geothermal heat pumps (GHPs) are used to extract heat from the ground and transfer it to the building's interior during the winter months. In the summer, the process is reversed, and the heat is extracted from the building's interior and transferred to the ground. This technology provides efficient heating and cooling solutions for buildings, reducing the need for fossil fuel-based systems and lowering energy costs.

#### **13.5.5.2 Hot Water**

Geothermal technology can also be used to provide hot water for buildings. A geothermal heat pump can extract heat from the ground and transfer it to a hot water tank, providing a constant supply of hot water for the building's needs. This eliminates the need for a separate hot water system and reduces energy costs.

#### **13.5.5.3 Snow and Ice Melting**

Geothermal technology can also be used for snow and ice melting in outdoor areas, such as driveways and walkways. Piping is installed under the surface, and hot water is circulated through the pipes to melt snow and ice. This solution is more efficient and environmentally friendly than traditional methods of snow and ice removal, such as salt and chemicals.



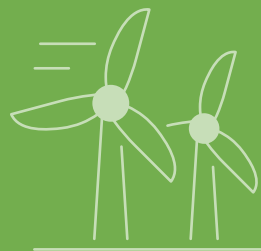

# 14

## RENEWABLE ENERGY

The Energy Conservation Building Code 2023 emphasizes the importance of renewable energy in sustainable development and climate change mitigation. It provides guidelines for integrating renewable energy systems in buildings to reduce dependence on fossil fuels. This includes types of renewable systems, design and installation requirements, and their benefits. The chapter supports Pakistan's energy conservation and renewable energy goals, offering guidance for building professionals on renewable system implementation. Additionally, it outlines the necessity of adhering to industry codes and standards, like IEC, NEC, and IEEE, for the safe installation of photovoltaic equipment.

## CHAPTER NO 14

# RENEWABLE ENERGY

---

## 14.1 INTRODUCTION

Renewable energy plays a critical role in sustainable development and mitigating the impacts of climate change. The Energy Conservation Building Code 2023 acknowledges this and provides guidelines on integrating renewable energy systems in buildings to promote energy conservation by reducing reliance on fossil fuels. This chapter offers an overview of these guidelines, covering the types of renewable energy systems that can be used, their design and installation requirements, and the benefits of using them. It also highlights the role of renewable energy in meeting energy conservation and efficiency targets, as well as contributing to Pakistan's overall renewable energy targets. This chapter aims to guide building professionals and stakeholders in implementing renewable energy systems to achieve sustainable development and promote energy conservation.

The installation of photovoltaic (PV) equipment is subject to industry codes and standards to ensure a safe and functional installation. Electrical contractors must be aware of these codes and standards. This chapter briefly discusses the International Electrotechnical Commission (IEC) Standards, National Electrical Code (NEC) requirements, and The Institute of Electrical and Electronics Engineers Inc. (IEEE) interconnection standards.

## 14.2 SOLAR ENERGY

The solar panels can be provided on roof tops and integrated photovoltaic panels on walls/windows as well as solar photovoltaic (PV) banks on open areas.

### 14.2.1 Solar Photovoltaic Power Generation System

PV solar generation system (Both Old/New Domestic buildings) shall be designed at minimum of 1 KW per Marla for domestic /residential consumers based on the technical analysis of solar capacity potential of the building by considering the surrounding buildings and their shades on the concerned building.

### 14.2.2 Solar Photovoltaic Power Generation System

PV solar generation system (Both Old/New Public, Commercial & Industry buildings) shall be designed at minimum of 10 KW for 1000 units (kwh) for average monthly consumption based on the technical analysis of solar capacity potential of the building by considering the surrounding buildings and their shades on the concerned building. The power generated may be used for inhouse utilization (Off-

grid) or for transfer to the grid (On-grid). The Authority shall have required provisions in the building bye-laws and mechanism for required clearances and approvals.

### 14.2.3 On-grid Application (Net metering)

Net metering connection for domestic, public, commercial and industry purpose, the consumer shall comply DISCO code for the Net Metering as per NEPRA (Alternative and Renewable Energy) Distributed Generation and Net Metering Regulation 2015.

## 14.3 SELECTION OF PV MODULE, INVERTER AND BATTERIES

The solar system must comply the following minimum international standards according to certifications issued by the IEC for selection of the solar related products:

- i. IEC 61215-1:2021 - Terrestrial photovoltaic (PV) modules - Design qualification and type approval - Part 1: Test requirements.
- ii. IEC 61730-1:2016 Ed 1- Photovoltaic (PV) module safety qualification - Part 1: Requirements for construction.
- iii. IEC 61730-2:2016 Ed 1 - Photovoltaic (PV) module safety qualification - Part 2: Requirements for testing.
- iv. IEC 61701:2020 Photovoltaic (PV) modules - Salt mist corrosion testing.
- v. IEC 61726:2013 Photovoltaic (PV) modules - Ammonia corrosion testing.
- vi. IEC-60068-2-68 Environmental testing - Part 2-68: Tests - Test L: Dust and sand.

### 14.3.2 PV Module Efficiency

Minimum PV module efficiency must be at least 20 %.

#### 14.3.2.1 Inverters

Inverters shall comply UL 1741 /IEC 62109 and it is the standard for Inverters, Converters, Controllers and Interconnection System Equipment. Efficiency for on grid inverters must have minimum 97 % and minimum 92 % for hybrid inverter. Ingress protection minimum IP 67.

#### 14.3.2.2 Batteries

- i. IEC 61427-1 (Secondary cells and batteries for renewable energy storage - General requirements and methods of test - Part 1: Photovoltaic off-grid application).
- ii. IEC 61427-2 (Secondary cells and batteries for Renewable Energy Storage - General Requirements and methods of test - Part 2: On-grid application).

## 14.4 ORIENTATION & FACING

The designer must consider the Solar Array orientation towards true south and degree of tilt shall be close to latitude degree of that specific area for flat roof or ground.

### 14.5 MOUNTING STRUCTURE

- i. The PV solar panel mounting metallic structure should be fixed mount L2 or L3 or above structure where required with 12 Gauge thickness, mounted on concrete base above ground level.
- ii. The entire mechanical structure should be hot dipped galvanized and powder coated for longer life of the structure. Structure should be hot dip galvanized up to min 80 microns.
- iii. The mounting structure must be engineered for wind resistance min for 150 km per hour and safety as per geographical location of site.
- iv. Module should be fixed with the frame through SS bolts. The bolts should be tightened at the required angle.
- v. The Nuts, Bolts & Washers for modules & Mounting structures must be stainless steel material with appropriate gauge.

### 14.6 SHADING EFFECTS

Designer must consider an appropriate distance between different rows of solar arrays that must be taken into account for avoiding shading and free working space. The designer must also consider the shadings occurs due to the trees, building structure that obstruct sunlight in its way.

### 14.7 LOAD BEARING CAPACITY OF ROOF:

Designer must need to assess the load bearing capacity of roof ie dead and live load must be taken into account while designing solar system on the roof of either new or old buildings.

### 14.8 SOLAR CABLE STANDARD

Designer must comply with EN 50618:2014 or equivalent international standard for cables for photovoltaic applications.

### 14.9 COMPLIANCE DOCUMENTATION

Compliance documents should include plans, drawings, specifications, and other relevant documentation that demonstrate compliance with the relevant building codes and regulations. These documents should be submitted to the relevant authorities for review and approval.



# 15

## ENERGY MANAGEMENT SYSTEM

The Energy Management System (EnMS) chapter of the Building Code, in line with ISO 50001:2018, provides a framework for managing energy in the operational phase of buildings. It focuses on establishing energy policies, processes, and objectives to improve energy performance, efficiency, and consumption. This chapter, which addresses both physical and soft interventions, applies to the design and procurement of energy-related facilities and systems. It guides organizations in setting and achieving energy targets, developing action plans, and ensuring compliance with the chapter's standards for continual energy performance improvement.

## CHAPTER NO 15

# ENERGY MANAGEMENT SYSTEM

---

## 15.1 INTRODUCTION

The Energy Management System (EnMS) in line with the International Standard for Energy Management Systems ISO 50001:2018 requirements, sets out an energy management framework for establishing policies, processes, procedures and specific energy-tasks to meet an organization's energy objectives. It requires an organization to define its desired energy performance, and work towards achieving its stated objective(s).

This chapter has been developed to address the operational phase of buildings (whether newly constructed or existing). The technical sections of the Building Code are specific to the design, construction, renovation, and extension phases of buildings and most of these are physical in nature (hard interventions), with the exception of auditable records and related documentation. This section has been developed in reference to the ISO 50001 standard on Energy Management Systems (EnMS). But only those clauses of the ISO 50001 standard have been considered that are related to the operational phase of buildings and also provide for soft interventions.

The aim of this chapter is to enable organizations to establish the systems and processes necessary to continually improve energy performance, including energy efficiency, energy use and energy consumption. This chapter applies to the activities under the control of the organization. This chapter does not apply to product use by end-users outside of the scope and boundaries of the EnMS, nor does it apply to product design outside of facilities, equipment, systems or energy-using processes. This chapter does apply to the design and procurement of facilities, equipment, systems or energy-using processes within the scope and boundaries of the EnMS.

Development and implementation of an EnMS includes an energy policy, objectives, energy targets and action plans related to its energy efficiency, energy use, and energy consumption while meeting applicable legal requirements and other requirements. An EnMS enables an organization to set and achieve objectives and energy targets, to take actions as needed to improve its energy performance and to demonstrate the conformity of its system to the requirements of this chapter.

## 15.2 SCOPE

Scope of this chapter is to keep the operational phase of buildings optimized in terms of energy use and energy consumption and for maintaining proper documentation and records that are necessary for building energy performance.

## 15.3 RESPONSIBILITY AND COMPLIANCE REQUIREMENT

The building owner, who takes approval from competent authority for construction of building is responsible for compliance of this section. In case if owner sublet or rent out whole or part of building to other party then in both situation the owner will be responsible to compliance with this section.

## 15.4 ENERGY MANAGEMENT SYSTEMS (ENMS)

Combining EnMS with Building Code is an effective way to ensure that large buildings are designed, constructed, operated and maintained with energy efficiency in mind. Building Codes set minimum requirements for energy efficiency in new construction and major renovations, while EnMS provides a framework for sustainable use of energy as well as continual improvement in energy performance. This section gives an overview on how to combine EnMS with Building Codes in large buildings.

### 15.4.1 Development of Energy Team

The building operator or owner demonstrates his commitment to the development and effective implementation as well as the continuous improvement of the EnMS. The building operator or owner will nominate/constitute an energy team lead by an energy manager. The energy team is responsible to keep the EnMS on track. It will prepare and maintain all applicable and relevant procedures, work instructions, forms, and checklists that are required for an efficient and effective operation of the building(s).

### 15.4.2 Regular Team Meeting

Regular energy team meetings are intended to provide a forum for discussion and improvement of the operations and to provide the management/operator with all the relevant information related to an effective EnMS implementation. The team meetings will be conducted at specified intervals with regard to suitability, adequacy and effectiveness of the EnMS. Each team meeting will consider the following points as a basic agenda:

- a) Presenting energy performance and status of EnMS implementation
- b) Collection and maintaining up to date energy information

- c) Monitoring and measurement results
- d) Status of energy action plans
- e) Recommendations for improvements
- f) Review of the current energy-related performance and the associated EnPI compared to a specified previous period
- g) Documentation/minutes of meeting for reference and record

#### **15.4.3 Awareness Raising and Training of Staff**

This section is mandatory for EnMS. The purpose of awareness raising and trainings is to ensure that all energy team members and relevant staff, whose tasks have the potential to affect the buildings' energy performance and the EnMS, are competent on the basis of appropriate education, training, skills or experience. For this, the training needs have to be identified to ensure that the relevant staff members are well aware of the EnMS procedures, their roles and responsibilities for achieving and maintaining the desired energy performance. For raising the awareness and sensitizing the staff and building occupants with regard to energy efficiency and climate protection, the building owner shall display awareness material on Energy Efficiency and Conservation at prominent places of the building.

Additionally, staff members should be trained on how to operate the energy monitoring systems and understand how to interpret the data generated by the systems. If the EnMS is established together with building codes, the training can be extended accordingly. This increases the awareness of both topics.

#### **15.4.4 Defining an Energy Policy**

An energy policy is a statement that outlines an organization's commitment to managing energy use and improving energy performance. The energy policy should be developed and approved by top management and communicated throughout the organization. For public buildings, the energy policy should include specific goals and targets for reducing energy consumption, improving energy efficiency, and reducing greenhouse gas emissions.

#### **15.4.5 Establishing an Energy Baseline (EnB)**

Before implementing an energy management system, it is essential to establish a baseline for energy use in the building. This baseline can be determined by analyzing energy consumption data from the past year (better the past three years) or by conducting an energy audit. Building codes may also require the establishment of an energy baseline as part of their energy efficiency requirements.

#### **15.4.6 Development of an Energy Management Action Plan**

After establishing an energy baseline, the next step is to develop an energy management plan that outlines specific actions to improve energy efficiency in the building. The energy management plan should include energy-saving measures that comply with building codes and identify additional opportunities for improvement



beyond the code requirements. The energy management plan should be developed based on the results of the energy audit and input from building occupants, facility managers, and other stakeholders.

#### **15.4.7 Implement Energy Saving Measures**

After developing an energy management plan that complies with building codes, the next step is to implement energy-saving measures. This may involve upgrading lighting systems, improving HVAC systems, or installing energy-efficient equipment. Building codes may require specific energy-saving measures, while EnMS can help identify additional opportunities for improvement beyond the code requirements. This is again an advantage of the continuous improvement approach of EnMS.

#### **15.4.8 Monitor and Measure Energy Performance**

Monitoring and measuring the energy performance are critical components of an energy management system. Energy consumption data should be collected regularly to track progress towards energy reduction goals and identify areas for improvement. Building codes may require regular energy audits or commissioning to verify compliance with energy efficiency requirements. Monitoring and measuring energy performance should be done with digital measurement equipment wherever possible.

#### **15.4.9 Internal and 3rd Party Energy Audit**

Internal audits are used to monitor compliance with and effectiveness of the EnMS, legal requirements and strategic and operational energy objectives. Energy audits are carried out and are documented for relevant areas by the division managers and responsible staff. Where appropriate, external experts shall be consulted. Energy audits are carried out at regular intervals, but at least once a year in the relevant areas.

The selection of auditors is carried out objectively and impartially. The auditors must be able to demonstrate qualifications in accordance with their task and must not bear direct responsibility for the area to be audited. Where appropriate, external experts shall be appointed as auditors. The implementation and results of the audits are carried out in accordance with the competent authority. Defined checklists are used, which are constantly being expanded as part of improving the performance of the EnMS. In the internal audits, the effectiveness of the EnMS, corrective and preventive measures, compliance with the defined energy policy and strategic and operational energy targets as well as deviations are considered and documented.

All results of the internal audits and the energy audits are recorded in corresponding checklists and reports, discussed at the end with all relevant staff and is communicated to the management. All documents created as part of the audits (audit reports, checklists, deviations, etc.) are managed and archived by the building operator or relevant department.

#### 15.4.10 Performance Reporting

An energy performance report of the building(s) shall be submitted by the owner to the respective authority on yearly basis. This performance report should be based on the good practices of building energy audit such as ASHRAE Level II. It must provide the following information on the energy performance of the building(s):

1. Analysis of energy use and consumption based on measurement and other data:
  - a) Identification of current types of energy
  - b) Evaluation and comparison of past and current energy use(s) and consumption
2. Identification of significant/major energy users (areas/equipment/systems) in the building(s)
3. Determination and prioritization of opportunities for improving energy performance
4. Estimation of future energy use(s) and energy consumption.

#### 15.4.11 Documented Information

An effective EnMS is based on a proper documentation of all its elements and reference to other related documents. Documentation should be preferably created/done in electronic form. The energy team or relevant department is responsible for maintaining the respective documentation and record. A proper EnMS documentation includes (but is not limited to) the following documents:

1. EnMS Manual/Handbook
2. Official notifications for energy team and EnMS focal person
3. Energy Policy
4. Strategic and operational energy targets and action plans
5. Energy review (audit) reports
6. Energy baseline and EnPIs
7. Energy audit database
8. Utility Bills/invoices of at least past 3 years
9. Captive Power operation/generator log
10. Electricity design/wiring drawings/layout
11. Equipment drawings and specification
12. Documents related to staff training/awareness
13. Suggested improvement for energy performance
14. Operational control procedures and work instructions
15. Information on building design
16. Other relevant documents



# 16

## CHARGING PROVISIONS FOR ELECTRIC VEHICLE

New or reconstructed parking facilities are mandated to install Electric Vehicle Charging Infrastructure under certain conditions: if a new off-street parking facility has more than 10 spaces, or if an existing facility with 20 or more spaces expands its capacity by 30% or more. The site design must include necessary electrical and ventilation infrastructure, accessible parking, and connections for potential future charging stations. Additionally, designated parking spaces for Electric Vehicles should be equipped with safety features like barricades and canopies, especially in open spaces, to ensure protection and convenience.

## CHAPTER NO 16

# CHARGING PROVISIONS FOR ELECTRIC VEHICLE

All new or reconstructed parking structures or lots / plazas shall be required to install Electric Vehicle Charging Infrastructure according to Table 16.1 when one of the following conditions is met:

1. The development includes a new off-street parking facility with more than 10 spaces; or
2. The parking capacity of an existing building, site, or parking facility with 20 or more spaces is increased by 30 percent or more (expressed as  $[\text{number of additional spaces}] / [\text{number of existing spaces}] \times 100$ ).
3. Site design must provide electrical, associated ventilation, accessible parking, and wiring connection to transformer to support the additional potential future electric vehicle charging stations.

Fuel station layout shall be designed with the provision of parking spaces designated for Electric Vehicles including Canopy on Chargers (in case of open space). The allocated spaces shall have safety precautions e.g., barricaded parking space and safety barrier for charger protection etc.

**Table 16-1. EV Charging Requirements for New and Reconstructed Parking Structures**

Sr. No	Land Use Type	Percentage of Parking Spaces
1	High-rise Residential	%10-5
2	Retail, Restaurants	%2
3	Office, medical	%3
4	Industrial	%1
5	Institutional, municipal	%3
6	Recreational/entertainment/cultural	%1
7	Other	%3

These requirements may be revised upward or downward as part of an application for a conditional use permit or planned unit development based on verifiable information pertaining to parking.

## 16.1 GENERAL STATION REQUIREMENTS

Size. A standard-sized parking space shall be used for an electric vehicle charging station where such a station is required or planned.

### 16.1.1 Equipment Standards and Protection.

1. **Clearance.** Charging station equipment mounted on pedestals, light posts, bollards or other devices shall be a minimum of 12-24 inches clear from the face of curb.
2. **Charging Station Equipment.** Charging station outlets and connector devices shall be according to the OEMs specifications. It shall be mounted, and located as not to impede pedestrian movement or create trip hazards on footpaths.
3. **Charging Station Equipment Protection.** When the electric vehicle parking space is perpendicular or at an angle to curb face and charging equipment, adequate equipment protection, such as wheel stops or concrete-filled steel-bollard shall be used.

### 16.1.2 Signage

Electric vehicle charging stations, other than in residential use, shall have posted signage allowing only charging electric vehicles to park in such spaces. For the purposes of this subsection, “charging” means that an electric vehicle is parked at an electric vehicle charging station and is connected to the charging station equipment. Signage for parking of electric vehicles shall include:

- i. Information on the charging station to identify voltage and amperage levels and any time of use, fees, or safety information.
- ii. Restrictions shall be included on the signage, if removal provisions are to be enforced by the property owner.
- iii. As appropriate, directional signs to effectively guide motorists to the charging station space(s).

### 16.1.3 Lighting

Site lighting shall be provided where electric vehicle charging station (EVCS) is installed unless charging is for daytime purposes only.

## 16.2 ACCESSIBLE FACILITIES

Where electric vehicle charging points are provided in the parking lots or parking garages, accessible electric vehicle charging points in new / renovated

parking lots / plazas shall be provided according to the ratios shown in Table 16.2. The first column indicates the number of parking bays / spaces provided on-site and the second column indicates the number of accessible charging points that are to be provided for the corresponding number(s) of parking bays / spaces.

Table 16-2. Minimum Number of Accessible Electric Vehicle (EV) Charging		
Sr. No	Number of Parking Bays / Spaces	Minimum accessible EV charging points
1	50–5	1
2	100–51	2
3	150–101	3

Accessible electric vehicle charging points should be located in close proximity to the building or facility entrance and shall be connected to a barrier-free accessible route of travel. It is not necessary to designate the accessible electric vehicle charging points exclusively for the use of disabled persons.

### 16.3 CHARGING AND PARKING

EVCS parking spaces are to be included in the calculation for both the number of minimum and maximum parking spaces required, as provided by the Energy Conservation Building Code 2023.

EVCS parking spaces, where provided for public use, are reserved for parking and charging electric vehicles only, except as otherwise provided by the Energy Conservation Building Code 2023.

### 16.4 DECOMMISSIONING

Unless otherwise directed by National Energy Efficiency and Conservation Authority (NEECA). Within ninety (90) days of cessation of use of the EVCS, the property owner or operator shall restore the site to its original condition. Should the property owner or operator fail to complete said removal within ninety (90) days, NEECA shall conduct the removal and disposal of improvements at the property owner or operator's sole cost and expense.

**Note:** For further details regarding EV Charging Infrastructure requirements, please refer to Electric Vehicle Charging Infrastructure Regulations 2023.



# 17

## WATER REUSE SYSTEMS

The Wastewater Reuse chapter in the Energy Conservation Building Code 2023 sets guidelines for safe, sustainable wastewater reuse in buildings for non-potable purposes, emphasizing treatment and disinfection processes to aid water conservation and sustainable development in Pakistan.

## CHAPTER NO 17

# WATER REUSE SYSTEMS

---

## 17.1 INTRODUCTION

The chapter on Wastewater Reuse in the Energy Conservation Building Code 2023 outlines the requirements and guidelines for the safe and sustainable use of wastewater in buildings. This chapter aims to promote water conservation and reduce the strain on freshwater resources by encouraging the reuse of wastewater for non-potable purposes such as toilet flushing, irrigation, and cooling. The chapter also emphasizes the importance of maintaining proper treatment and disinfection processes to ensure the safety of the recycled wastewater. By implementing the standards set forth in this chapter, buildings in Pakistan can contribute to the country's efforts to conserve water and promote sustainable development.

### 17.1.1 Efforts of Pak-EPA on Wastewater Reuse

The Pakistan Environmental Protection Agency (Pak-EPA) is proactively promoting the reuse of wastewater throughout the country. To ensure the safe and sustainable use of recycled wastewater, Pak-EPA has developed a range of policies, guidelines, and regulations. One of these is the National Environmental Quality Standards for Wastewater, introduced in 2005, which defines the quality of wastewater and its acceptable use for various purposes. In 2014, Pak-EPA also developed the National Policy for Safe Use of Wastewater in Agriculture, aimed at promoting the secure and sustainable use of wastewater in agriculture. Overall, Pak-EPA's efforts are vital for the implementation of efficient and environmentally-friendly wastewater management practices in Pakistan.

## 17.2 RESOURCE MANAGEMENT

Water reuse presents a climate-independent water source that is controlled locally and has a positive impact on the environment. It offers the opportunity for communities to reduce their reliance on surface water and groundwater sources, while also minimizing the diversion of water from vulnerable ecosystems. Furthermore, water reuse has the potential to lower nutrient loads from wastewater discharges into waterways, leading to a decrease in pollution and its effects. Overall, water reuse is an eco-friendly and sustainable solution that offers numerous benefits.

### 17.2.1 Performance

It is estimated that through moderate gains in water efficiency the federal



government could save as much as 240 million per year. Water savings at federal and provincial levels, approximately 40%, could provide enough water to supply a population of approximately 2.1 million. Water reuse is a proven technology that has been used for more than 40 years across the world, reclaimed water can be used in numerous applications to satisfy most water demands, depending on the level of treatment. The water is treated to meet regulatory guidelines for the intended end use. Typical uses for reclaimed water include:

1. Irrigation
2. Groundwater Recharge
3. Industrial Cooling Processes
4. Toilet Flushing
5. Vehicle Washing

The Pakistan Environmental Protection Agency (EPA) has played a crucial role in developing and enforcing wastewater management policies, as well as establishing standards for drinking water quality. Most cities in Pakistan have also developed their own criteria or guidelines for the safe and beneficial use of reclaimed water. In 2018, the EPA released a technical document called “Guidelines for Water Treatment and Reuse,” which provides important information on local requirements, as well as guidelines for treating and using recycled water.

### **17.3 PART 1 - GENERAL CRITERIA FOR WASTEWATER REUSE**

General criteria for wastewater reuse refer to the guidelines and standards that determine the quality of treated wastewater and the permissible uses for different purposes. These criteria typically take into account the health and environmental risks associated with the reuse of wastewater, as well as the suitability of the water for specific uses. Common criteria for wastewater reuse include the National Environmental Quality Standards for Wastewater, which provide quality standards for wastewater and its use for different purposes, and the World Health Organization’s Guidelines for Safe Use of Wastewater, Excreta and Greywater, which provide recommendations for the safe use of wastewater in agriculture, aquaculture, and other applications.

#### **17.3.1 Summary**

This Section includes water reuse systems for:

1. Municipal-supplied reclaimed water
2. In situ water reclamation
  - i Rain water
  - ii Gray water
  - iii Black water

#### **17.3.2 Specifier Note**

Coordinate requirements specified under this section with work specified

under related sections. Following sections are required based on the water supply and reuse projects.

#### 17.3.2.1 *Related Sections*

The 2018 policy guidelines of the Pakistan Environmental Protection Agency outline regulatory requirements for various aspects of environmental protection, including wastewater management. These guidelines establish standards for the quality of reclaimed water and provide detailed information on the treatment and reuse of recycled water. Compliance with these regulatory requirements is essential to ensure the safe and sustainable use of reclaimed water in various applications, such as irrigation and industrial processes. Rainwater Harvesting Code under Building Code of Pakistan developed in 2023.

### 17.4 SUBMITTALS

#### 17.4.1 Product Data

Unless specified otherwise, provide the following for each type of product included in the work described in this Section;

##### 17.4.1.1 *Specifier Note*

International green building rating systems, such as USGBC-LEED™ v3 and version V4.1, provide credits for reducing water use and implementing innovative wastewater technologies, including water reuse. The Federal Water Efficiency Best Management Practices (BMPs) also offer guidance on designing, constructing, and operating facilities in a water-efficient manner. According to Federal Energy Management Program-14- Best Management Practices (FEMP BMP #14), many Federal facilities can meet their water needs using non-potable water from alternative sources, such as municipal-supplied reclaimed water, treated gray water from on-site sanitary sources, and stormwater. Initially developed by FEMP, the BMPs mandated Federal agencies to adopt cost-effective measures to reduce water consumption. To accommodate changes in water, use patterns, technological advancements, and regulatory requirements, the Environmental Protection Agency's Water Sense Office updated the original BMPs.

#### 17.4.2 Water Efficiency

Water efficiency is measured by the water reuse rates, expressed in gallons per day (gpd) per unit, for the following items:

1. Municipal-supplied reclaimed water
2. In situ water reclamation
3. Water Budget: submit a water budget statement that includes the calculations used to develop it. The statement should demonstrate how the approved water budget improves water efficiency over the baseline, and how the water reuse system(s) align with the approved water budget.

### 17.4.3 Baseline

Use the EPA-Pak guidelines for water fixtures and the occupancy rate to calculate the baseline water budget.

## 17.5 DESIGNER/INSTALLER QUALIFICATIONS

The qualifications of the designer and installer are crucial factors in ensuring the successful design and installation of a water reuse system. The designer should have expertise in water reuse technology and be knowledgeable about local codes and regulations. The installer should be licensed and experienced in installing water reuse systems. Hiring qualified professionals can help ensure that the system operates efficiently, effectively, and safely.

### 17.5.1 Quality Assurance

Addressing water scarcity and promoting water resource sustainability is increasingly reliant on water reuse strategies. Quality assurance plays a vital role in ensuring the safety and effectiveness of recycled water. To ensure the quality of recycled water, several measures must be taken, including source water selection, treatment processes, distribution and monitoring, and regulatory compliance. The standards for recycled water quality should align with its intended use and consider potential risks to human health and the environment. Effective treatment processes, such as filtration, disinfection, and advanced oxidation, should be employed to eliminate pathogens, pollutants, and other contaminants from the recycled water. Distribution and monitoring systems must be established to verify that the water meets the required standards and identify and address any issues that may arise promptly.

To guarantee the safety and quality of recycled water, regulatory compliance is critical. Guidelines and regulations must be established to oversee the treatment, distribution, and monitoring of recycled water, and periodic inspections and audits should be performed to ensure adherence. A comprehensive and systematic approach to quality assurance is necessary to promote the safety and sustainability of water reuse. In Pakistan, water reuse is an essential strategy for conserving water resources in energy-efficient buildings. To ensure the safety and efficacy of recycled water, it is crucial to systematically select the source water, implement efficient treatment processes, such as filtration, disinfection, and advanced oxidation, and establish dependable distribution and monitoring systems. Adherence to guidelines and regulations is also crucial in ensuring the safety of recycled water. Thus, adopting a comprehensive quality assurance approach in water reuse is critical to promoting sustainable development and conserving energy in Pakistan.

### 17.5.2 Specifier Note

The Public Health Engineering Departments (PHEDs) in each province assist rural communities with their drinking water, wastewater, environmental

training, infrastructure resilience, and utility management needs, and offer solutions to any problems they encounter. In urban areas, the responsibility for water and sanitation services falls on the Tehsil Municipal Authorities (TMAs), which in some cities delegate this responsibility to Water and Sanitation Agencies (WASAs) for operation and maintenance.

One key difference between Punjab, Sindh, and other provinces such as KP is that in Punjab and Sindh, community-based organizations (CBOs) take over rural water supply schemes for operation and maintenance after construction, while in other provinces like KP, the PHED assumes responsibility for operation and maintenance. Non-governmental organizations (NGOs) such as WaterAid and Action Against Hunger also install water supply and sanitation systems in the two provinces, often creating localized water management institutions and governance systems. These departments and organizations are therefore responsible for guiding, assisting, and providing safe solutions for water supply and reuse across all provinces of Pakistan. They are also responsible for developing policy guidelines for gray water reuse in provincial water regulations, which may include the use of a three-tiered system described below:

In Pakistan, there is a three-tiered system for reclaimed water usage. Tier 1, known as the Reclaimed Water General Permit, allows private residential direct reuse of gray water for a flow of less than 400 gallons per day. However, certain conditions must be met to limit human contact with the gray water. For systems that process over 400 gpd, don't meet the list of requirements, and/or commercial, multifamily, and institutional systems, Tier 2 requires a standard permit. Regulators evaluate systems over 3,000 gpd on an individual basis under Tier 3.

To ensure that all water reuse facilities and programs comply with the necessary regulations, the National Database of Water Reuse Facilities is maintained by the Pakistan Council of Research in Water Resources (PCRWR) in Islamabad, as well as the Pakistan Environmental Protection Agency. This comprehensive web database is organized into key topic areas including Utilities, Facilities, Treatment Technologies, and End Use. Information can be queried by individual states as well as nationwide. The 2020 International Plumbing Code provides guidelines for the use of gray water systems in flushing water closets and urinals, as well as for subsurface landscape irrigation.

### **17.5.3 Regulatory Requirements for Gray Water Reuse**

The compliance with applicable codes, rules, and regulations is necessary to meet the regulatory requirements for the reuse of gray water. This includes adherence to the International Plumbing Code and other relevant guidelines.

### **17.5.4 Designer/Installer Qualifications**

To carry out the work specified in this Section, hire an experienced licensed plumbing contractor who specializes in the systems needed for this Project and has a track record of successful performance. The Contractor should have at least 3-5 years of experience in designing, constructing, and installing water reuse systems that meet the requirements for this Project.

#### 17.5.4.1 Pre-Installation Meetings

Prior to commencing work in this section, schedule a pre-installation meeting at least one week in advance. It is mandatory for parties directly involved in this Section to attend the meeting.

- a) Ensure coordination with the installation of plumbing fixtures, equipment, and piping.
- b) Ensure coordination with the installation of the rainwater harvesting system.
- c) Ensure coordination with the municipal supplier.

The contractor and consultant should review the conditions of operations, procedures, and coordination with related work, and prepare an agenda covering the following items:

- a) Tour, inspect, and discuss the conditions of work.
- b) Review the installation schedule.
- c) Review the required permits and inspections.
- d) Review the monitoring and maintenance procedures.
- e) Review the environmental procedures.

After completing the aforementioned steps, the contractor must submit the Operation and Maintenance Manuals. The manuals should include instructions for routine operation and maintenance of the water reuse system(s) and must be provided to the following parties as appropriate:

- a) Municipal-supplied reclaimed water
- b) In situ water reclamation utilizing:
  - i) Rain water
  - ii) Gray water
  - iii) Black water

The instructions provided should cover procedures for normal and peak loading conditions, as well as periods of shutdown. Peak loading conditions refer to peak hydraulic and pollutant loading conditions, while periods of shutdown include power failures, equipment failure, and normal maintenance shutdowns. Additionally, the instructions must include procedures for emergency response in the event of system failure. The local officials must be trained to maintain the record and the system.

## 17.6 MONITORING AND MAINTENANCE

During the contractor liability period, which begins at Substantial Completion and initial acceptance, the Contractor is responsible for providing regular maintenance for a minimum of one year. During this period, the Contractor should conduct daily, weekly, monthly, and quarterly monitoring to evaluate performance and ensure that system components are adjusted and functioning properly. The water quality should also be verified to confirm that it is satisfactory for the intended use.

If in situ water reuse systems are employed, the Contractor should also monitor and test water quality in accordance with ASTM E2635 and verify that the water reuse rate is consistent with the water budget. Additionally, the Contractor should make any necessary minor adjustments and document system performance, including the rate and amount of water reuse and the quality of reclaimed water. If in situ water reuse systems are used, the Contractor should also document the quality of reclaimed water before and after treatment. Finally, the Contractor should provide recommendations for improvements to the system.

## 17.7 PART 2 – PRODUCTS

### 17.1.1 Specifier Note

Pakistan Environmental Protection Guidelines mandates that Provincial Agencies and Federal agencies must adopt sustainable environmental practices, which includes procuring biobased, environmentally friendly, energy-efficient, water-efficient, and recycled-content products. It also directs these agencies to reduce their water consumption intensity by 2% annually from the baseline of 2017 until the end of fiscal year 2020 or by 16% by the end of fiscal year 2021.

Guiding Principle #3 under the Whole Building Design Guidelines-2021 requirements further elaborates on the need to protect and conserve water (Source: <https://www.wbdg.org/design-objectives/sustainable/protect-serve-water>). Pakistan Environmental Protection Guidelines directs Provincial Agencies and Federal agencies to employ water-efficient landscape and irrigation strategies, such as water reuse and recycling, to decrease the consumption of outdoor potable water by at least 50% compared to conventional methods, including plant species and densities.

The PCRWR and Rain Water Conservation and harvesting codes establish numerous Federal and provincial requirements in various areas, including:

- A 2% annual reduction in potable water consumption intensity through fiscal year 2020, or a 26% reduction by the end of fiscal year 2023, compared to the fiscal year 2017 baseline.
- A 2% annual reduction in agency industrial, landscaping, and agricultural water consumption, or a 20% reduction by the end of fiscal year 2020, compared to the fiscal year 2015 baseline.
- The identification, promotion, and implementation of water reuse strategies that are consistent with state law and reduce potable water consumption.

## 17.8 WATER REUSE SYSTEM

Water reuse systems treat and recycle wastewater for various purposes like irrigation, industrial processes, and drinking water. They help to address water scarcity by providing an alternative water source. The recycled water undergoes physical, chemical, and biological treatments to remove contaminants. It can be used for landscaping, agriculture, industrial processes, and even drinking water.

However, public perception can be a challenge, so educating people about the benefits of water reuse is important. In summary, water reuse systems are a sustainable solution to water scarcity.

### 17.8.1 Specifier Note

The Building Code of Pakistan and Pakistan Institute of Development Economics (PIDE) have developed guidelines for water conservation in buildings, including rainwater harvesting codes. These guidelines take a comprehensive approach for facilities managers, with a chapter dedicated to the basic design components of onsite wastewater recycling, reclaimed water, and rainwater harvesting. The guidelines also prioritize easy access to system design for effective monitoring and maintenance, including process control programs. Dual distribution systems are recommended to prevent cross-connections of reclaimed water and potable water lines, and to avoid misuse of reclaimed water. Additionally, backflow prevention devices should be installed on reclaimed water lines to prevent incidental human misuse.

### 17.8.2 Specifier Note

Reclaimed water, which is treated and recycled by municipalities for non-potable use, is usually available at a much lower rate than potable water. However, its use may be restricted by local codes. In the past, centralized municipal sewage treatment facilities have been the main option for water disposal for provincial facilities. But due to concerns about water supply availability, facility managers are now considering on-site recycling of wastewater or gray water.

#### 17.8.2.1 *Municipal-Supplied Reclaimed Water*

- 1 The system design should ensure that the pressure of reclaimed water is 10 psi lower than that of the potable water mains to prevent backflow and siphonage in case of accidental cross-connection.
- 2 Reclaimed water mains should be run at least 12 inches lower in elevation than potable water mains and horizontally at least five feet away.
- 3 The quality of reclaimed water should be reviewed to ensure that there are no harmful effects, such as salt buildup, on piping or equipment from long-term use. The design should be adjusted as necessary.

ASTM E2635, known as the Standard Practice for Water Conservation in Buildings Through In-Situ Water Reclamation, provides guidelines for replacing potable water supplies with reclaimed water in cases where potable water quality is not necessary.

#### 17.8.2.2 *In Situ Water Reclamation*

The in-situ water reclamation must meet the specifications outlined in ASTM E2635, and the water reclamation system must be designed and executed with reliability and redundancy in mind. The system design must consider normal and peak loading conditions, as well as periods of shutdown, and must take into account operations and treatment during these periods.

1. Water Source: Water that have been captured from one or more of the following:

- i Rain Water, including snowmelt and stormwater runoff.
- ii Gray Water
- iii Black Water

### 17.9 PART 3 - EXECUTION

The execution of a water reuse system typically involves the installation and integration of various components such as filters, pumps, and tanks. The system design and installation must adhere to local regulations and standards to ensure the recycled water meets the required quality criteria. The treatment process may involve physical, chemical, and biological treatments, depending on the intended use of the recycled water. After treatment, the recycled water can be distributed through a separate pipeline or combined with fresh water supplies. Regular maintenance and monitoring of the system are also critical to ensure optimal performance and safety. In summary, the successful execution of a water reuse system requires careful planning, installation, and maintenance to provide a reliable and sustainable source of water.

#### 17.10 COMPLIANCE DOCUMENTATION

Compliance documents should include plans, drawings, specifications, and other relevant documentation that demonstrate compliance with the relevant building codes and regulations. These documents should be submitted to the relevant authorities for review and approval.



## CHAPTER NO 18

# APPENDIX A - DEFINITIONS, ABBREVIATIONS, AND ACRONYMS

---

## 18.1 INTRODUCTION

Certain terms, abbreviations, and acronyms are defined in this section for the purposes of this standard. These definitions are applicable to all sections of this code. Terms that are not defined shall have their ordinarily accepted meanings within the context in which they are used. Ordinarily accepted meanings shall be based upon American standard English language usage as documented in an unabridged dictionary accepted by the adopting authority.

## 18.2 DEFINITIONS

**Addition:** an extension or increase in floor area or height of a building outside of the existing building envelope.

**Alteration:** any replacement, change, rearrangement, or addition to a building or its systems and equipment; any modification in construction or building equipment; maintenance, repair or change in the building usage shall not constitute an alteration.

**Area:** see roof and wall, conditioned floor, day lighted, facade, fenestration and lighted floor.

**Authority having jurisdiction:** the agency or agent responsible for enforcing this Code.

**Automatic:** self-acting, operating by its own mechanism when actuated by some non-manual influence, such as a change in current strength, pressure, temperature or mechanical configuration.

**Automatic control device:** a device capable of automatically turning loads off and on without manual intervention.

**Balancing, air system:** adjusting airflow rates through air distribution system devices, such as fans and diffusers, by manually adjusting the position of dampers, splitters vanes, extractors, etc., or by using automatic control devices, such as constant air volume or variable air volume boxes.

**Balancing, hydronic system:** adjusting water flow rates through hydronic distribution system devices, such as pumps and coils, by manually adjusting the position valves or by using automatic control devices, such as automatic flow control valves.

**Ballast:** a device used in conjunction with an electric-discharge lamp to cause the lamp to start and operate under proper circuit conditions of voltage, current, waveform, electrode heat, etc.

**Boiler:** a self-contained low-pressure appliance for supplying steam or hot water.

**Boiler, packaged:** a boiler that is shipped complete with heating equipment, mechanical draft equipment, and automatic controls; usually shipped in one or more sections. A packaged boiler includes factory-built boilers manufactured as a unit or system, is disassembled for shipment, and reassembled at the site.

**Building:** a structure wholly or partially enclosed within exterior walls, or within exterior and party walls, and a roof, affording shelter to persons, animals, or property.

**Building, existing:** a building or portion thereof that was previously occupied or approved for occupancy by the authority having jurisdiction.

**Building complex:** a group of buildings in a contiguous area under single ownership.

**Building entrance:** any doorway, set of doors, turnstiles, or other form of portal that is ordinarily used to gain access to the building by its users and occupants.

**Building envelope:** the exterior plus the semi-exterior portions of a building. For the purposes of determining building envelope requirements, the classifications are defined as follows:

- a. Building envelope, exterior: the elements of a building that separate conditioned spaces from the exterior.
- b. Building envelope, semi-exterior: the elements of a building that separate conditioned space from unconditioned space or that encloses semi-heated spaces through which thermal energy may be transferred to or from the exterior, or to or from unconditioned spaces, or to or from conditioned spaces.

**Building exit:** any doorway, set of doors, or other form of portal that is ordinarily used only for emergency egress or convenience exit.

**Building grounds lighting:** lighting provided through a building's electrical service for parking lot, site, roadway, pedestrian pathway, loading dock, and security applications.

**Building material:** any element of the building envelope through which heat flows and that heat is included in the component U-factor calculations other than air films and insulation.

**Circuit breaker:** a device designed to open and close a circuit by non-automatic means and to open the circuit automatically at a predetermined over-current without damage to itself when properly applied within its rating.

**Class of construction:** for the building envelope, a subcategory of roof, wall, floor, slab-on-grade floor, opaque door, vertical fenestration, or skylight.

**Coefficient of Performance (COP) – cooling:** the ratio of the rate of heat removal to the rate of energy input, in consistent units, for a complete refrigerating system or some specific portion of that system under designated operating conditions.

**Coefficient of Performance (COP) – heating:** the ratio of the rate of heat delivered to the rate of energy input, in consistent units, for a complete heat pump system, including the compressor and, if applicable, auxiliary heat, under designated operating conditions.

**Commercial building:** all buildings except for multi-family buildings of three stories or fewer above grade and single-family buildings.

**Construction documents:** drawings and specifications used to construct a building, building systems, or portions thereof.

**Control:** to regulate the operation of equipment.

**Control device:** a specialized device used to regulate the operation of equipment.

**Cool roof:** a property of a surface that describes its ability to reflect and reject heat. Cool roof surfaces have both a light color (high solar reflectance) and a high emittance (can reject heat back to the environment).

**Vertical fenestration:** all fenestration other than skylights. Trombe wall assemblies, where glazing installed within 12 inch (30 mm) of a mass wall, are considered walls, not fenestration.

**Dead band:** the range of values within which a sensed variable can vary without initiating a change in the controlled process.

**Demand:** the highest amount of power (average Btu/h over an interval) recorded for a building or facility in a selected time frame.

**Design capacity:** output capacity of a system or piece of equipment at design conditions.

**Design conditions:** specified environmental conditions, such as temperature and light intensity, required to be produced and maintained by a system and under which the system must operate.

**Distribution system:** conveying means, such as ducts, pipes, and wires, to bring substances or energy from a source to the point of use. The distribution system includes such auxiliary equipment as fans, pumps, and transformers.

**Door:** all operable opening areas (which are not fenestration) in the building envelope, including swinging and roll-up doors, fire doors, and access hatches. Doors that are more than one-half glass are considered fenestration. For the purposes of determining building envelope requirements, the classifications are defined as follows:

- Non-swinging: roll-up sliding, and all other doors that are not swinging doors.
- Swinging: all operable opaque panels with hinges on one side and opaque revolving doors.

**Door area:** total area of the door measured using the rough opening and including the door slab and the frame.

**Dwelling unit:** a single unit providing complete independent living facilities for one or more persons, including permanent provisions for living, sleeping, eating, cooking, and sanitation

**Economizer, air:** a duct and damper arrangement and automatic control system that together allow a cooling system to supply outdoor air to reduce or eliminate the need for mechanical cooling during mild or cold weather.

**Economizer, water:** a system by which the supply air of a cooling system is cooled indirectly with water that is itself cooled by heat or mass transfer to the environment without the use of mechanical cooling

**Efficacy:** the lumens produced by a lamp/ballast system divided by the total watts of input power (including the ballast), expressed in lumens per watt.

**Efficiency:** performance at specified rating conditions.

**Emittance:** the ratio of the radiant heat flux emitted by a specimen to that emitted by a blackbody at the same temperature and under the same conditions.

**Enclosed building:** a building that is totally enclosed by walls, floors, roofs and openable devices such as doors and operable windows.

**Energy:** the capacity for doing work. It takes a number of forms that may be transformed from one into another such as thermal (heat), mechanical (work), electrical, and chemical. Customary measurement units are: kilojoules (kJ) or British thermal units (Btu) in this document.

**Energy Efficiency Ratio (EER):** the ratio of net cooling capacity in Btu/h to total rate of electric input in watts under designated operating conditions.

**Energy Factor (EF):** a measure of water heater overall efficiency.

**Equipment:** devices for comfort conditioning, electric power, lighting, transportation, or service water heating including, but not limited to furnaces, boilers, air conditioners, heat pumps, chillers, water heaters, lamps, luminaires, ballasts, elevators, escalators or other devices or installations.

**Existing equipment:** equipment previously installed in an existing building.

**Facade area:** area of the facade, including overhanging soffits, cornices, and protruding columns, measured in elevation in a vertical plane, parallel to the plane of the face of the building. Non-horizontal roof surfaces shall be included in the calculations of vertical facade area by measuring the area in a plane parallel to the surface.

**Fan system power:** the sum of the nominal power demand (nameplate horse power) of motors of all fans that are required to operate at design conditions to supply air from the heating or cooling source to the conditioned space(s) and return it to the source of exhaust it to the outdoors.

**Fenestration:** all areas (including the frames) in the building envelope that let in light including windows, plastic panels, clerestories, skylights, glass doors that are more than one half glass and glass block walls.

- a. **Skylight:** a fenestration surface having a slope of less than 60 degrees from the horizontal plane. Other fenestration, even if mounted on the roof of a building, is considered vertical fenestration.
- b. **Vertical fenestration:** all fenestration other than skylights. Trombe wall assemblies, where glazing is installed within 12 in. of a mass wall, are considered walls, not fenestration.

**Fenestration area:** total area of the fenestration measured using the rough opening and including the glazing, sash, and frame. For doors where the glazed vision area is less than 50% of the door area, the fenestration area is the glazed vision area. For all other doors, the fenestration area is the door area.

**Floor area gross:** the sum of the floor areas of the spaces within the building including basements, mezzanine and intermediate-floored tiers and penthouses with headroom height of 7.5 ft or greater. It is measured from the exterior faces of exterior walls or from the centerline of walls separating buildings, but excluding covered walkways, open roofed over areas, porches and similar spaces, pipe trenches, exterior terraces or steps, chimneys, roof overhangs and similar features.

- a) **Gross building envelope floor area:** the gross floor area of the building envelope, but excluding slab-on-grade floors.
- b) **gross conditioned floor area:** the gross floor area of conditioned spaces.
- c) **Gross lighted floor area:** the gross floor area of lighted spaces.
- d) **Gross semi-heated floor area:** the gross floor area of semi-heated spaces.

**Flue damper:** a device in the flue outlet or in the inlet of or upstream of the draft control device of an individual, automatically operated, fossil fuel-fired appliance that is designed to automatically open the flue outlet during appliance operation and to automatically close the flue outlet when the appliance is in standby condition.

**Fossil fuel:** fuel derived from a hydrocarbon deposit such as petroleum, coal, or natural gas derived from living matter of a previous geologic time.

**Fuel:** a material that may be used to produce heat or generate power by combustion.

**Grade:** the finished ground level adjoining a building at all exterior walls.

**Guest room:** any room or rooms used or intended to be used by a guest for sleeping purposes.

**Heat capacity:** the amount of heat necessary to raise the temperature of a given mass 1°F. Numerically, the heat capacity per unit area of surface (Btu/ft<sup>2</sup>-°F) is the sum of the products of the mass per unit area of each individual material in the roof, wall or floor surface multiplied by its individual specific heat.

**Heating Seasonal Performance Factor (HSPF):** the total heating output of a heat pump during its normal annual usage period for heating (in Btu) divided by the total electric energy input during the same period.

**Historic:** a building or space that has been specifically designed as historically significant.

**HVAC system:** the equipment, distribution systems, and terminals that provide, either collectively or individually, the processes of heating, ventilating or air conditioning to a building or portion of a building.

**Infiltration:** the uncontrolled inward air leakage through cracks and crevices in any building element and around windows and doors of a building caused by pressure differences across these elements due to factors such as wind, inside and outside temperature differences (stack effect), and imbalance between supply and exhaust air systems.

**Installed interior lighting power:** the power in watts of all permanently installed general, task, and furniture lighting systems and luminaries.

**Integrated part-load value (IPLV):** a single number figure of merit based on part-load EER, COP, or KW/ton expressing part-load efficiency for air-conditioning and heat pump equipment on the basis of weighted operation at various load capacities for the equipment.

**Kilovolt-ampere (kVA):** where the term “kilovolt-ampere” (kVA) is used in this code, it is the product of the line current (amperes) times the nominal system voltage (kilovolts) times 1.732 for three-phase currents. For single-phase applications, kVA is the product of the line current (amperes) times the nominal system voltage (kilovolts).

**Kilowatt (kW):** the basic unit of electric power, equal to 1000 W.

**Labeled:** equipment or materials to which a symbol or other identifying mark has been attached by the manufacturer indicating compliance with specified standard or performance in a specified manner.

**Lamp:** a generic term for man-made light source often called bulb or tube. Generally, following types are used.

- (a) Compact fluorescent lamp.
- (b) Fluorescent lamp.
- (c) General service lamp.
- (d) high-intensity discharge (HID) lamp.
- (e) Incandescent lamp.
- (f) Reflector lamp.

**Lighted floor area, gross:** the gross floor area of lighted spaces.

**Lighting, decorative:** lighting that is purely ornamental and installed for aesthetic effect. Decorative lighting shall not include general lighting.

**Lighting, emergency:** lighting that provides illumination only when there is a general lighting failure.

**Lighting, general:** lighting that provides a substantially uniform level of illumination throughout an area. General lighting shall not include decorative lighting or lighting that provides a dissimilar level of illumination to serve a specialized application or feature within such area.

**Lighting Efficacy (LE):** the quotient of the total lumens emitted from a lamp or lamp/ballast combination divided by the watts of input power, expressed in lumens per watt.

**Lighting system:** a group of luminaires circuited or controlled to perform a specific function.

**Lighting power allowance:**

- a. Interior lighting power allowance: the maximum lighting power in watts allowed for the interior of a building
- b. Exterior lighting power allowance: the maximum lighting power in watts allowed for the exterior of a building

**Lighting Power Density (LPD):** the maximum lighting power per unit of area of a building classification of space function.

**Low-rise residential:** single-family houses, multi-family structures of three stories or fewer above grade, manufactured houses (mobile homes), and manufactured houses (modular).

**Luminaire:** a complete lighting unit consisting of a lamp or lamps together with the housing designed to distribute the light, position and protect the lamps, and connect the lamps to the power supply.

**Manual (non-automatic):** requiring personal intervention for control. Non-automatic does not necessarily imply a manual controller, only that personal intervention is necessary.

**Manufacturer:** the company engaged in the original production and assembly of products or equipment or a company that purchases such products and equipment manufactured in accordance with company specifications.

**Mean temperature:** one-half the sum of the minimum daily temperature and maximum daily temperature.

**Mechanical cooling:** reducing the temperature of a gas or liquid by using vapor compression, absorption, desiccant dehumidification combined with evaporative cooling, or another energy-driven thermodynamic cycle. Indirect or direct evaporative cooling alone is not considered mechanical cooling.

**Metering:** instruments that measure electric voltage, current, power, etc.

**Multifamily high-rise:** multifamily structures of four or more stories above grade.

**Multifamily low-rise:** multifamily structures of three or less stories above grade.

**Multiplication factor (M):** indicates the relative reduction in annual solar cooling load from overhangs and/or side fins with given projection factors, relative to the respective horizontal and vertical fenestration dimensions.

**Non-automatic:** see manual.

**Occupant sensor:** a device that detects the presence or absence of people within an area and causes lighting, equipment or appliances to be regulated accordingly.

**Opaque:** all areas in the building envelope, except fenestration and building service openings such as vents and grilles.

**Orientation:** the direction an envelope element faces, i.e., the direction of a vector perpendicular to and pointing away from the surface outside of the element. For vertical fenestration, the two categories are north-oriented and all other.

**Outdoor (outside) air:** air that is outside the building envelope or is taken from outside the building that has not been previously circulated through the building.

**Overcurrent:** any current in excess of the rated current of the equipment of the ampacity of the conductor. It may result from overload, short circuit or ground fault.

**Packaged Terminal Air Conditioner (PTAC):** a factory-selected wall sleeve and separate un-encased combination of heating and cooling components, assemblies or sections. It may include heating capability by hot water, steam or electricity and is intended for mounting through the wall to service a single room or zone.

**Party wall:** a firewall on an interior lot line used or adapted for joint service between two buildings.

**Permanently installed:** equipment that is fixed in place and is not portable or movable.

**Plenum:** a compartment or chamber to which one or more ducts are connected, that forms a part of the air distribution system and that is not used for occupancy or storage. A plenum often is formed in part or in total by portions of the building.

**Pool:** any structure, basin, or tank containing an artificial body of water for swimming, diving or recreational bathing. The terms include, but not limited to swimming pool, whirlpool, spa, hot tub.

**Process load:** the load on a building resulting from the consumption or release of process energy.

**Projection factor:** the ratio of the horizontal depth of the external shading projection divided by the sum of the height of the fenestration and the distance from the top of the fenestration to the bottom of the farthest point of the external shading projection, in consistent units.

**Projection factor, side-fin:** the ratio of the horizontal depth of the external shading projection divided by the distance from the window jamb to the farthest point of the external shading projection, in consistent units.

**Rated R-value of insulation:** the thermal resistance of the insulation alone as specified by the manufacturer in units of  $\text{h}\cdot\text{ft}^2\cdot^\circ\text{F}/\text{Btu}$  at a mean temperature of  $75^\circ\text{F}$ . Rated R-value refers to the thermal resistance of the added insulation in framing cavities or insulated sheathing only and does not include the thermal resistance of other building materials or air films. (See thermal resistance.)

**Readily accessible:** capable of being reached quickly for operation, renewal, or inspections without requiring those to whom ready access is requisite to climb over or remove obstacles or to resort to portable ladders, chairs, etc. In public facilities,



accessibility may be limited to certified personnel through locking covers or by placing equipment in locked rooms.

**Recirculating system:** a domestic or service hot water distribution system that includes a close circulation circuit designed to maintain usage temperatures in hot water pipes near terminal devices (e.g., lavatory faucets, shower heads) in order to reduce the time required to obtain hot water when the terminal device valve is opened. The motive force for circulation is either natural (due to water density variations with temperature) or mechanical (recirculation pump).

**Reflectance:** the ratio of the light reflected by a surface to the light incident upon it.

**Resistance, electric:** the property of an electric circuit or of any object used as part of an electric circuit that determines for a given circuit the rate at which electric energy is converted into heat or radiant energy and that has a value such that the product of the resistance and the square of the current gives the rate of conversion of energy.

**Reset:** automatic adjustment of the controller set point to a higher or lower value.

**Residential:** spaces in buildings used primarily for living and sleeping. Residential spaces include, but are not limited to, dwelling units, hotel/motel guest rooms, dormitories, nursing homes, patient rooms in hospitals, lodging houses, fraternity/sorority houses, hostels, prisons and fire stations.

**Roof:** the upper portion of the building envelope, including opaque areas and fenestration, that is horizontal or tilted at an angle of less than 60° from horizontal.

**Roof area, gross:** the area of the roof measured from the exterior faces of walls or from the centerline of party walls.

**Service:** the equipment for delivering energy from the supply or distribution system to the premises served.

**Service water heating:** heating water for domestic or commercial purposes other than space heating and process requirements.

**Set point:** point at which the desired temperature (°F) of the heated or cooled space is set.

**Shading Coefficient (SC):** the ratio of solar heat gain at normal incidence through glazing to that occurring through 1/8 in thick clear, double-strength glass. Shading coefficient, as used herein, does not include interior, exterior or integral shading devices.

**Simulation program:** a computer program that is capable of simulating the energy performance of building systems.

**Single-zone system:** an HVAC system serving a single HVAC zone.

**Site-recovered energy:** waste energy recovered at the building site that is used to offset consumption of purchased fuel or electrical energy supplies.

**Slab-on-grade floor:** that portion of a slab floor of the building envelope that is in contact with ground and that is either above grade or is less than or equal to 24 in

below the final elevation of the nearest exterior grade.

**Solar energy source:** source of thermal, chemical, or electrical energy derived from direct conversion of incident solar radiation at the building site.

**Solar Heat Gain Coefficient (SHGC):** the ratio of the solar heat gain entering the space through the fenestration area to the incident solar radiation. Solar heat gain includes directly transmitted solar heat and absorbed solar radiation, which is then reradiated, conducted, or convected into the space.

**Space:** an enclosed space within a building. The classifications of spaces are as follows for the purpose of determining building envelope requirements.

- a) **Conditioned space:** a cooled space, heated space, or directly conditioned space.
- b) **Semi-heated space:** an enclosed space within a building that is heated by a heating system whose output capacity is greater or equal to 3.4 Btu/h-ft<sup>2</sup> of floor area but is not a conditioned space.
- c) **Unconditioned space:** an enclosed space within a building that is not conditioned space or a semi-heated space. Crawlspace, attics, and parking garages with natural or mechanical ventilation are not considered enclosed spaces.

**Story:** portion of a building that is between one finished floor level and the next higher finished floor level or the roof, provided, however, that a basement or cellar shall not be considered a story.

**System:** a combination of equipment and auxiliary devices (e.g., controls, accessories, interconnecting means, and terminal elements) by which energy is transformed so it performs a specific function such as HVAC, service water heating or lighting.

**System, existing:** a system or systems previously installed in an existing building.

**Terminal:** a device by which energy form a system is finally delivered, e.g., registers, diffusers, lighting fixtures, faucets, etc.

**Thermal block:** a collection of one or more HVAC zones grouped together for simulation purposes. Spaces need not be contiguous to be combined within a single thermal block.

**U-factor (Thermal Transmittance):** heat transmission in unit time through unit area of a material or construction and the boundary air films, induced by unit temperature difference between the environments on each side. Units of U are Btu/h-ft<sup>2</sup>-°F or Watts /(m<sup>2</sup>.°C).

**Thermostat:** an automatic control device used to maintain temperature at a fixed or adjustable set point.

**Tinted (as applied to fenestration):** Bronze, green, or grey coloring that is integral with the glazing material. Tinting does not include surface applied films such as reflective coatings, applied either in the field or during the manufacturing process.

**Transformer:** a piece of electrical equipment used to convert electric power from

one voltage to another voltage.

- A. Dry-type transformer:** a transformer in which the core and coils are in a gaseous or dry compound.
- b. liquid-immersed transformer:** a transformer in which the core and coils are immersed in an insulating liquid.

**Variable Air Volume (VAV) system:** HVAC system that controls the dry-bulb temperature within a space by varying the volumetric flow of heated or cooled supply air to the space.

**Vent damper:** a device intended for installation in the venting system or an individual, automatically operated, fossil fuel-fired appliance in the outlet or downstream of the appliance draft control device, which is designed to automatically open the venting system when the appliance is in operation and to automatically close off the venting system when the appliance is in standby or shutdown condition.

**Ventilation:** the process of supplying or removing air by natural or mechanical means to or from any space. Such air is not required to have been conditioned.

**Wall:** that portion of the building envelope, including opaque area and fenestration, that is vertical or tilted at an angle of 60° from horizontal or greater. This includes above- and below-grade walls, between floor spandrels, peripheral edges of floors, and foundation walls. For the purpose of determining building envelope requirements, the classifications are defined as follows:

- a. above-grade wall: a wall that is not below grade wall.
- b. below-grade wall: that portion of a wall in the building envelope that is entirely below the finish grade and in contact with the ground.

**Wall area, gross:** the overall area off a wall including openings such as windows and doors, measured horizontally from outside surface to outside service and measured vertically from the top of the floor to the top of the roof. The gross wall area includes the area between the ceiling and the floor for multi-story buildings.

**Water heater:** vessel in which water is heated and is withdrawn for use external to the system.

**Zone, HVAC:** A space or group of spaces within a building with heating and cooling requirements that are sufficiently similar so that desired conditions (e.g., temperature) can be maintained throughout using a single sensor (e.g., thermostat or temperature sensor).

**Definitions to Sustainable Development:** The definition of sustainable development, as specified herein, is in accordance with ASTM E2114.

**Definitions to Water Reuse:** The definition of water reuse can be found in ASTM E2635 and is also specified in this document.

**Black Water:** Blackwater refers to untreated wastewater that comes from urinals and water closets. This type of wastewater typically contains human waste from toilets, bidets, and urinals, as well as small amounts of toilet paper, soap, and personal care products. Blackwater is highly contaminated and can harbor various

pathogens, including bacteria, viruses, and parasites that pose a significant risk to public health if left untreated. Unlike greywater, which originates from non-toilet plumbing fixtures like sinks and showers, blackwater cannot be reused without undergoing extensive treatment processes to eliminate contaminants.

**Gray Water:** Graywater refers to untreated wastewater from sources such as bathtubs, showers, bathroom wash basins, clothes washing machines, and laundry tubs, as well as condensation pan water from refrigeration equipment and air-conditioners, hot tub drains water, pond and fountain drain water, and cistern drain water. It contains traces of dirt, soap, food, and other household cleaning products, but not human waste. Greywater is less contaminated than blackwater and can be reused for non-potable purposes such as landscape irrigation, toilet flushing, and laundry. Proper treatment processes must be in place to remove any harmful contaminants before reuse. The reuse of greywater can conserve freshwater resources and reduce the environmental impact of untreated wastewater.

**Reclaimed Water:** Reclaimed water is defined as the water that is used more than one time before it passes back into the natural water cycle. Reclaimed water is considered non-potable but may be highly treated and used for approved purposes other than drinking water.

**Recycled Water:** Recycled water refers to treated wastewater that has undergone a purification process to eliminate contaminants and make it safe for reuse. This type of water can originate from different sources, including domestic and industrial wastewater, stormwater, and agricultural runoff. The purification process typically involves a combination of physical, chemical, and biological treatments to remove impurities from the wastewater. The resulting water is suitable for non-potable uses, such as industrial processes, toilet flushing, and landscape irrigation. Recycled water plays a crucial role in water-scarce areas as it helps to reduce the demand for freshwater, conserve water resources, and minimize the discharge of untreated wastewater into the environment.

**Water Reuse:** Water reuse is defined as cycling water one or more times for beneficial use as reclaimed water. Water reuse, also known as water recycling or reclaimed water, is the process of treating and reusing wastewater or other water sources for beneficial purposes. The treated water can be used for various non-potable purposes such as irrigation, toilet flushing, industrial processes, and cooling. The water reuse process involves treating the wastewater to remove contaminants and impurities, including physical, chemical, and biological treatments. The treated water must meet specific quality standards and undergo rigorous testing before reuse to ensure it is safe and suitable for its intended purpose. Water reuse is an important strategy to conserve freshwater resources, reduce water pollution, and address the growing water scarcity challenges faced by many regions worldwide.

**Toxicity/IEQ in Water Reuse:** The earth has been naturally recycling and reusing water for millions of years through the water cycle. However, water utilities have developed technologies to accelerate these processes. When discussing water quality, utilities tend to focus on the various stages of treatment rather than the specific technologies employed, as there are multiple techniques for achieving

similar results. The four primary stages of treatment are: Primary Treatment, Secondary Treatment, Tertiary or Advanced Treatment, and Disinfection. Reclaimed water is engineered to ensure safety and reliability, making its quality more predictable than many surface and groundwater sources.

While reclaimed water is of high quality, it is not directly used for drinking purposes in Pakistan. Instead, it is distributed through a separate piping network, which keeps reclaimed water pipes completely separate from potable water pipes. In Pakistan, lavender (light purple) pipes are exclusively used for distributing reclaimed water to differentiate it from potable water.

**Field Quality Control:** Field quality control is essential for ensuring the safe and reliable operation of water reuse systems in Pakistan. To achieve this, it is important to verify that the system design conforms to approved codes and regulations, and that the reclaimed water is properly disinfected and clearly labeled as non-potable. Additionally, regular monitoring of water quality is necessary to identify any potential issues and ensure that the system is functioning effectively. With proper field quality control measures in place, water reuse systems can help conserve valuable water resources while maintaining public health and safety.

**Water Quality:** Coordinate with the work specified in the section of local water supply agencies, organizations, or departments in accordance with the Environmental Management Guidelines to facilitate water monitoring for surface and groundwater.

**Field Inspection:**

- Ensure that the installed system is consistent with the approved design and applicable codes, regulations, and standards. Also, make sure that the reclaimed water is disinfected through an approved method that uses one or more disinfectants, such as chlorine, iodine, or ozone.
- Verify that the distribution piping and reservoirs are appropriately labeled to indicate that they contain non-potable water.
- Confirm that gray water is dyed blue or green using a food-grade vegetable dye.

**Reclaimed Wastewater Quality:** Wastewater reuse is a widespread practice in both industrialized and developing countries, for purposes such as agriculture, toilet flushing, and stormwater storage. In regions where water supply is limited, planned reuse of municipal or industrial wastewater is common. Unplanned wastewater reuse has been used for centuries, but may not be efficient or safe for the environment. Reusing wastewater and conserving water can help maximize existing water supplies and reduce the need to tap into new sources of high-quality water, which can be expensive and have negative environmental impacts.

## CHAPTER NO 19

**ANNEXURES****19.1 TECHNICAL COMMITTEE FOR ECBC-2023**

The Technical Committee of NEECA Board participated in the consultations organized in the respective areas as well as attended the Steering Committee meetings. The development of the Energy Conservation Building Code 2023 is the culmination of the efforts of many individuals who served on the task force (Technical Committee) responsible for its creation. The task force comprised experts from various sectors of the building industry, including professionals from the engineering and architecture fields, energy efficiency specialists, and representatives from relevant government bodies.

While it may not be possible to acknowledge each individual's contributions to the development of the Code, it is crucial to recognize the members of the Task Force who worked tirelessly to revise the Building Code of Pakistan (Energy Provisions-2011). Their collective efforts and expertise have resulted in the creation of a comprehensive and effective set of provisions that will promote energy efficiency, safety, and economic health in the building industry in Pakistan.

The Task Force's contributions are a testament to their dedication and commitment to the cause of promoting energy efficiency and sustainable building practices in Pakistan. Their hard work and expertise have helped create a document that will serve as a benchmark for the building industry in Pakistan and contribute to the country's efforts to reduce energy consumption and costs while enhancing safety and economic health;

Engr. Zeeshan Ullah	Convener, Director Buildings, NEECA
Engr. Sajjad Khan	Member, Director Transportation, NEECA
Engr. Muhammad Umar	Member, Manager Technical, ECF, NEECA
Engr. Muhamamd Zeeshan Ghias	Member, Director Electrical, NEECA
Engr. Feroz Baig	Member, Director Industry, NEECA
Engr. Yousaf Zia	Additional Registrar, PEC
Engr. Muhammad Riaz Baig	Member, Senior Engineer, Fahim, Nanji & deSouza
Engr. Dr. Muhammad Mohsin Aman	Member, Associate Professor, Department of Electrical Engineering, NED University of Engineering and Technology, Karachi

Engr. Mujtaba Hussain Somoro,	Member, Deputy Director Building Control North, Capital Development Authority (CDA)
Mr. Muhammad Azim Khosro,	Member, Director Urban Affairs, Ministry of Climate Change (MoCC)
Engr. Ayaz Mahmood	Member, Senior Engineer Electrical, NESPAK
Engr. Anwar-Ul-Haq Azeem	Member, Chief Engineer (North), Pakistan Public Works Department (Pak PWD), Ministry of Housing and Works
Engr. Dr. Fiaz Chaudhry	Member, Director, LUMS Energy Institute, LUMS
Engr. Dr. Abdul Rehman Kashif	Member, Associate Professor, Electrical Engineering Department, University of Engineering and Technology (UET), Lahore
Engr. Shahid Iqbal	Member, Chief Engineer Civil PDO, AJK Power Development Organization Muzaffarabad, Azad Jammu and Kashmir (AJK)
Engr. Dr. Zakauallah Khan Gandapur	Member, Member PEC Governing Body/Convener PEC Think Tank on Energy Development Committee
Engr. Saeed-Ud-Din Gilani,	Member, Chief Engineer, Electricity Department, Muzaffarabad, Azad Jammu and Kashmir (AJK)
Engr. Khurram Shahzad Durrani	Member, Director Renewable Energy, PEDO
Mr. Mian Sultan	Member, M/s Creative Electronics (Pvt) Ltd.
Engr. Dr. Muhammad Ali Memon	Member, Working Group for Standardization of Building Codes Standards and Specifications for Low-Cost
Engr. Syed Shahid Hussain Jafri	Member, PEC Task Force for Development of Pakistan Electric and telecommunication Safety Code (PETSAC-2014)
Dr. M. A. Irfan Mufti	Member, Director Centre for Industrial and Building Energy Audits (CIBEA), (UET Peshawar)
Engr. Aqrab Ali Rana	Member, CEO, Pakistan Green Building Council (PGBC), Lahore
Ar. Mishaal Rozina Merchant	Member, Senior/Principal Architect, Studio Ecomorph, PCATP, Karachi
Ar. Muhammad Arif Changezi	Member, President of Institute of Architects, Pakistan (IAP), Karachi
Prof. Architect Yasmeen Lari,	Member, Founding Chair, Pakistan Council for Architects and Town Planners (PCATP)
Engr. Fayaz Alam	Co-opted Member, Superintending Engineer, Water and Power Department, Gilgit Baltistan (GB)

Mr. Khurram Fareed	Member, PCATP
Engr. Tafseer Ahmed Khan	Member, Ex-Member PEC Governing Body
Mr. Syed Imtiaz Ali Shah	Member, Managing Director (MD), Sindh Energy Efficiency and Conservation Authority (SEECA), Karachi, Sindh
Engr. Ali Raza Hafeez	Member, Program Engineer, Punjab Energy Efficiency and Conservation Authority (PEECA), Lahore
Ar. Talha Saeed	Energy Consultant, LUMS Energy Institute, Lahore
Ar. Navaira Najeeb	Energy Consultant, LUMS Energy Institute, Lahore
Engr. Mushtaq Ibrahim Soomro	Director Technical, Local Government Authority, Housing and Town Planning, Government of Sindh



## ABBREVIATIONS AND ACRONYMS

ECBC	Energy Conservation Building Code
AFUE	Annual fuel utilization efficiency
ANSI	American National Standards Institute
ARI	Air-Conditioning and Refrigeration Institute
ASHRAE	American Society of Heating, Refrigerating and Air-Conditioning Engineers Inc.
ASTM	American Society for Testing and Materials
Btu	British thermal unit
Btu/h	British thermal units per hour
Btu/ft <sup>2</sup> -°F	British thermal units per square foot per degree Fahrenheit
Btu/h- ft <sup>2</sup>	British thermal units per hour per square foot
Btu/h- ft <sup>2</sup> -°F	British thermal units per hour per lineal foot per degree Fahrenheit
°C	Celsius
cfm	cubic feet per minute
cm	centimeter
COP	coefficient of performance
EER	energy efficiency ratio
EF	energy factor
°F	Fahrenheit
ft	foot
h	hour
HC	heat capacity
h-ft <sup>2</sup> -°F/Btu	hour per square foot per degree Fahrenheit per British thermal unit
h-m <sup>2</sup> -°C/W	hour per square meter per degree Celsius per Watt
hp	horsepower (746 W)
HSPF	heating seasonal performance factor
HVAC	heating, ventilating, and air conditioning

I-P	inch-pound
in.	inch
IPLV	integrated part-load value
J	joule;
kJ	kilojoule
kVA	kilovolt-ampere
kW	kilowatt;(power)
kWh	kilowatt-hour; (energy)
LE	lighting efficacy
lin ft	linear foot
lin m	linear meter
lm	lumen
LPD	lighting power density
m	meter
mm	millimeter
NAECA	National Appliance Energy Conservation Act
PF	power factor
PTAC	packaged terminal air conditioner
R	R-value (thermal resistance)
SC	shading coefficient
SHGC	solar heat gain coefficient
SL	standby loss
VAV	variable air volume
VLT	visible light transmission
W	watt
W/ft <sup>2</sup>	watts per square feet
W/m <sup>2</sup>	watts per square meter
W/m <sup>2</sup> K	watts per square meter per degree kelvin
W/m-K	watts per lineal meter per degree kelvin
Wh	watthour

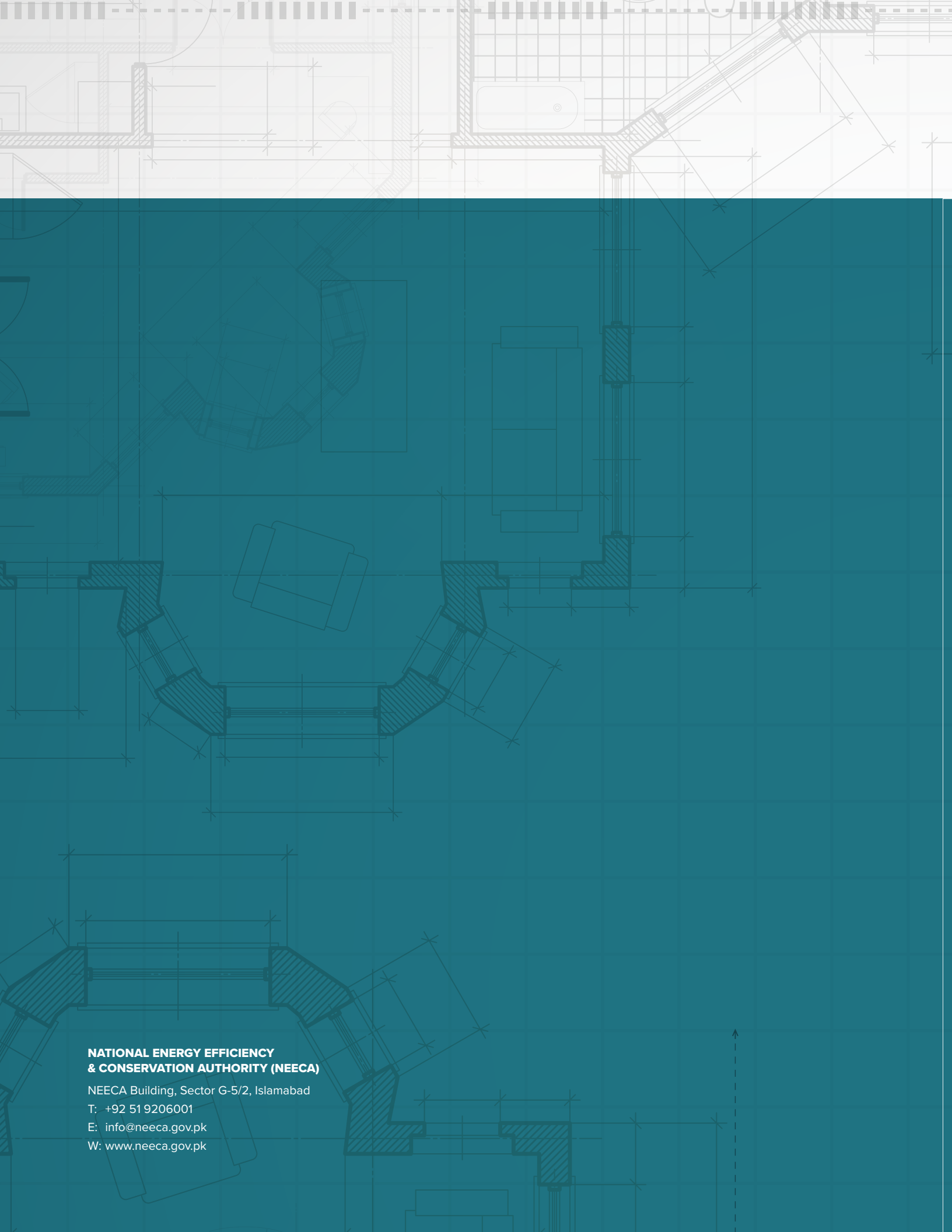

**NATIONAL ENERGY EFFICIENCY  
& CONSERVATION AUTHORITY (NEECA)**

NEECA Building, Sector G-5/2, Islamabad

T: +92 51 9206001

E: [info@neeca.gov.pk](mailto:info@neeca.gov.pk)

W: [www.neeca.gov.pk](http://www.neeca.gov.pk)

