

Terminations for steel wire ropes — Safety —

Part 3: Ferrules and ferrule-securing

The European Standard EN 13411-3:2004 has the status of a
British Standard

ICS 53.020.30; 77.140.99

National foreword

This British Standard is the official English language version of EN 13411-3:2004. It supersedes BS 5281:1975 which is withdrawn.

The UK participation in its preparation was entrusted to Technical Committee MHE/2, Wire ropes, which has the responsibility to:

- aid enquirers to understand the text;
- present to the responsible international/European committee any enquiries on the interpretation, or proposals for change, and keep the UK interests informed;
- monitor related international and European developments and promulgate them in the UK.

A list of organizations represented on this committee can be obtained on request to its secretary.

Cross-references

The British Standards which implement international or European publications referred to in this document may be found in the *BSI Catalogue* under the section entitled “International Standards Correspondence Index”, or by using the “Search” facility of the *BSI Electronic Catalogue* or of British Standards Online.

This publication does not purport to include all the necessary provisions of a contract. Users are responsible for its correct application.

Compliance with a British Standard does not of itself confer immunity from legal obligations.

This British Standard, was published under the authority of the Standards Policy and Strategy Committee on 7 July 2004

Summary of pages

This document comprises a front cover, an inside front cover, the EN title page, pages 2 to 29 and a back cover.

The BSI copyright notice displayed in this document indicates when the document was last issued.

Amendments issued since publication

Amd. No.	Date	Comments

© BSI 7 July 2004

ISBN 0 580 44021 4

EUROPEAN STANDARD

EN 13411-3

NORME EUROPÉENNE

EUROPÄISCHE NORM

June 2004

ICS 53.020.30; 77.140.99

English version

Terminations for steel wire ropes - Safety - Part 3: Ferrules and ferrule-securing

Terminaisons pour câbles en acier - Sécurité - Partie 3:
Manchons et boucles manchonnées

Endverbindungen für Drahtseile aus Stahldraht - Sicherheit
- Teil 3: Pressklemmen und Verpressen

This European Standard was approved by CEN on 16 April 2004.

CEN members are bound to comply with the CEN/CENELEC Internal Regulations which stipulate the conditions for giving this European Standard the status of a national standard without any alteration. Up-to-date lists and bibliographical references concerning such national standards may be obtained on application to the Central Secretariat or to any CEN member.

This European Standard exists in three official versions (English, French, German). A version in any other language made by translation under the responsibility of a CEN member into its own language and notified to the Central Secretariat has the same status as the official versions.

CEN members are the national standards bodies of Austria, Belgium, Cyprus, Czech Republic, Denmark, Estonia, Finland, France, Germany, Greece, Hungary, Iceland, Ireland, Italy, Latvia, Lithuania, Luxembourg, Malta, Netherlands, Norway, Poland, Portugal, Slovakia, Slovenia, Spain, Sweden, Switzerland and United Kingdom.



EUROPEAN COMMITTEE FOR STANDARDIZATION
COMITÉ EUROPÉEN DE NORMALISATION
EUROPÄISCHES KOMITEE FÜR NORMUNG

Management Centre: rue de Stassart, 36 B-1050 Brussels

© 2004 CEN All rights of exploitation in any form and by any means reserved
worldwide for CEN national Members.

Ref. No. EN 13411-3:2004: E

Contents

	page
Foreword.....	4
1 Scope	6
2 Normative references	6
3 Terms and definitions	7
4 List of hazards.....	8
5 Safety requirements and/or measures	8
5.1 Ferrule-secured system	8
5.1.1 General.....	8
5.1.2 Type testing.....	9
5.1.3 Instructions to be provided by the ferrule-secured system designer.....	10
5.2 Ferrules.....	10
5.2.1 Material	10
5.2.2 Dimensions.....	10
5.2.3 Manufacture and quality control of ferrule	10
5.2.4 Certificate	11
5.2.5 Marking	11
5.3 Ferrule-securing.....	11
5.3.1 General.....	11
5.3.2 Matching of ferrule to wire rope	11
5.3.3 Forming the eye	11
5.3.4 Pressing the ferrule	13
5.3.5 Quality control after pressing of the ferrule	13
6 Verification of the safety requirements and/or measures	14
6.1 Qualification of personnel	14
6.2 Tensile type test (FSET system designer)	14
6.3 Fatigue type test (FSET system designer)	14
6.4 Fatigue type test of Flemish eye ferrule-secured termination of crane hoist rope (FSET system designer).....	14
6.5 Ferrule dimensions before pressing (Ferrule manufacturer).....	14
6.6 Manufacture and quality control of ferrule (Ferrule manufacturer).....	14
6.7 Ferrules (FSET or ferrule-secured endless loop manufacturer).....	14
6.8 Matching of ferrule to wire rope (FSET or ferrule-secured endless loop manufacturer)	14
6.9 Forming the eye (FSET or ferrule-secured endless loop manufacturer)	15
6.10 Pressing the ferrule (FSET or ferrule-secured endless loop manufacturer)	15
6.11 Quality control after pressing the ferrule(s) (FSET or ferrule-secured endless loop manufacturer).....	15
7 Information for use	15
7.1 Marking	15
7.2 Certificate	15
Annex A (informative) Specification for one design of turn-back eye ferrule-secured termination	16
A.1 General.....	16
A.2 Types of terminations	16
A.3 Ropes for this design of ferrule	18
A.3.1 General.....	18
A.3.2 Rope types.....	18
A.3.3 Metallic cross sectional area factor	18
A.3.4 Rope grade	18
A.3.5 Types of rope lay	18

A.4	Tubing	18
A.4.1	General	18
A.4.2	Material	18
A.4.3	Straightness	18
A.4.4	Wall thickness	19
A.5	Identification and dimensions of ferrules (unpressed)	19
A.6	Matching wire rope to ferrule	22
A.7	Making the eye termination	25
A.7.1	Positioning of ferrule (Types A and B)	25
A.7.2	Pressing the ferrule	25
A.7.3	Ferrules after pressing	25
A.8	Information for use	27
A.8.1	Identification marks	27
A.8.2	Temperature limits	27
	Annex ZA (informative) Relationship of this European Standard with EU Directives	28
	Bibliography	29

Foreword

This document (EN 13411-3:2004) has been prepared by Technical Committee CEN/TC 168 "Chains, ropes, webbing, slings and accessories - Safety", the secretariat of which is held by BSI.

This European Standard shall be given the status of a national standard, either by publication of an identical text or by endorsement, at the latest by December 2004, and conflicting national standards shall be withdrawn at the latest by December 2004.

This document has been prepared under a mandate given to CEN by the European Commission and the European Free Trade Association, and supports essential requirements of EU Directive(s).

For relationship with EU Directive(s), see informative Annex ZA, which is an integral part of this document.

Annex A is informative.

EN 13411 consists of the following parts:

- Part 1: Thimbles for steel wire rope slings
- Part 2: Splicing of eyes for wire rope slings
- Part 3: Ferrules and ferrule-securing
- Part 4: Metal and resin socketing
- Part 5: U-bolt wire rope grips
- Part 6: Asymmetric wedge socket
- Part 7: Symmetric wedge socket

This is the first edition of this Part of this European Standard.

According to the CEN/CENELEC Internal Regulations, the national standards organizations of the following countries are bound to implement this European Standard: Austria, Belgium, Cyprus, Czech Republic, Denmark, Estonia, Finland, France, Germany, Greece, Hungary, Iceland, Ireland, Italy, Latvia, Lithuania, Luxembourg, Malta, Netherlands, Norway, Poland, Portugal, Slovakia, Slovenia, Spain, Sweden, Switzerland and United Kingdom.

Introduction

This European Standard is a Type C Standard as stated in EN 1070

This European Standard has been prepared to provide a means of conforming with the essential requirements of the Machinery Directive and associated EFTA regulations.

Purchasers ordering to this standard are advised to specify in their purchasing contract that the supplier operates an independently verified quality assurance system to ensure themselves that products claimed to comply consistently achieve the required level of quality.

It is understood that type testing of a ferrule-secured eye termination system is the responsibility of the ferrule-secured eye termination system designer.

It is also understood that the ferrule supplier is responsible for ensuring that the material, design and quality of the ferrule is in accordance with the ferrule-secured eye system designer's specification.

Ferrule-secured eyes manufactured by the ferrule-secured eye termination producer in accordance with this standard are permitted for use as rope terminations in the production of steel wire rope slings. They are also used as terminations for steel wire rope assemblies for raising, lowering and supporting loads.

The steel wire rope terminations concerned and the extent to which hazards, hazardous situations and events are covered are indicated in the scope of this document.

When provisions of this type C standard are different from those which are stated in type A or B standards, the provisions of this type C standard take precedence over the provisions of the other standards, for steel wire rope terminations that have been designed and produced according to the provisions of this type C standard.

1 Scope

This European Standard deals with the requirements for the ferrule-securing of eyes and endless loops.

It also deals with the requirements for ferrules for the ferrule-securing of eyes and endless loops.

This European Standard applies to the ferrule-securing of eye terminations formed either by a Flemish eye or turn-back eye and covers ferrules made of non alloy carbon steel and aluminium.

This European Standard applies to slings and assemblies using steel wire ropes for general lifting applications up to and including 60mm diameter conforming to EN 12385-4, lift ropes conforming to EN 12385-5 and spiral strand ropes conforming to EN 12385-10.

Type testing of ferrule-secured systems and manufacturing quality control requirements are also specified.

This European standard deals with all significant hazards, hazardous situations and events relevant to this particular steel wire rope termination when used as intended and under conditions of use which are foreseeable by the manufacturer.

This standard applies to terminations of steel wire ropes with ferrules and ferrule-securing which are manufactured after the date of this publication.

NOTE One design of ferrule-secured turn-back eye termination using an oval aluminium ferrule which satisfies the requirements of this European Standard is given for information in annex A.

2 Normative references

This European Standard incorporates by dated or undated reference, provisions from other publications. These normative references are cited at the appropriate places in the text and the publications are listed hereafter. For dated references, subsequent amendments to or revisions of any of these publications apply to this European Standard only when incorporated in it by amendment or revision. For undated references the latest edition of the publication referred to applies (including amendments).

EN 515, *Aluminium and aluminium alloys - Wrought products - Temper designations*

EN 1050:1996, *Safety of machinery – Principles of risk assessment*

EN 12385-1, *Steel wire ropes - Safety - Part 1: General requirements*

EN 12385-2:2002, *Steel wire ropes – Safety – Part 2: Definitions, designation and classification*

EN 12385-4, *Steel wire ropes – Safety – Part 4: Stranded ropes for general lifting applications*

EN 12385-5, *Steel wire ropes – Safety – Part 5: Stranded ropes for lifts*

EN 12385-10, *Steel wire ropes – Safety – Part 10: Spiral ropes for general structural applications*

EN ISO 12100-2, *Safety of machinery - Basic concepts, general principles for design - Part 2: Technical principles (ISO 12100-2:2003)*

3 Terms and definitions

For the purposes of this European Standard, the terms and definitions in EN 12385-2:2002 apply together with the following:

3.1

ferrule-secured eye termination (FSET)

eye formed at a rope end secured by means of a ferrule pressed on the rope

3.2

Flemish eye ferrule-secured termination

eye formed at a rope end secured by means of a ferrule pressed on the main body of the rope and the tail ends of the strands from the Flemish eye

3.3

turn-back eye ferrule-secured termination

eye formed at a rope end secured by means of a ferrule pressed onto the main body of the rope and the tail end

3.4

ferrule-secured endless loop

loop secured by ferrules pressed on the overlapping rope ends resulting in an endless rope assembly

3.5

competent person

designated person, suitably qualified by knowledge and experience, and with the necessary instruction to ensure that the required operations are correctly carried out

3.6

ferrule-secured system designer

person or organization that designs the ferrule-secured eye termination or ferrule-secured endless loop and assumes responsibility for type testing

3.7

ferrule manufacturer

person or organization that manufactures ferrules for a ferrule-secured eye termination or ferrule-secured endless loop system

3.8

ferrule-secured termination manufacturer

person or organization that manufactures the FSET and/or ferrule secured endless loop in accordance with the ferrule-secured termination system designer's instructions

4 List of hazards

This clause contains all the significant hazards, hazardous situations and events, as far as they are dealt with in this standard, identified by risk assessment as significant for this type of steel wire rope termination and which require action to eliminate or reduce the risk.

Accidental release of a load due to failure of a FSET puts at risk either directly or indirectly the safety or health of those persons within the danger zone.

Table 1 contains those hazards that require action to minimise risk identified by risk assessment as being specific and significant for ferrule-secured eyes and endless loops.

Table 1 — Hazards and associated requirements

Hazards identified in annex A of EN 1050: 1996	Relevant clause of annex A of EN ISO 12100-2:2003	Relevant clause/sub-clause of this standard	
1	Mechanical hazard	1.3	5
1e	Inadequacy of mechanical strength	1.3	5
27	Mechanical hazards and hazardous events		
27.4	Insufficient mechanical strength of parts	4.1.2.3	5
27.6	Inadequacy of selection of ropes and accessories and their inadequate integration into the machine	4.1.2.5, 4.3.1	5, 7
27.8	Abnormal conditions of assembly/testing/use/maintenance	4.2.4	6
1.7	Puncture hazard	1.3	5.3.4, 5.3.5

5 Safety requirements and/or measures

5.1 Ferrule-secured system

5.1.1 General

The ferrule-secured system shall comply with the safety requirements and/or protection measures of this clause.

In addition the ferrule-secured systems shall be designed according to the principles of EN ISO 12100 for relevant hazards but not significant, which are not dealt with in this document.

The ferrule-secured system designer shall carry out type testing in accordance with 5.1.2.

The ferrule-secured termination system designer shall provide instructions on how to produce the ferrule-secured termination and/or the ferrule-secured endless loop.

The instructions shall at least cover those items given in 5.1.3 and be supported with a written declaration that the system has passed the type testing requirements of 5.1.2.

In the particular case of oval ferrules with tapered ends used in the securing of the turn-back eye or endless loop where the rope end is contained within the ferrule, the ferrule-secured system designer shall provide means whereby the position of the rope end before and after pressing can be ascertained. This shall not include verification by marking the rope. Only the parallel portion of a ferrule shall be considered load bearing.

5.1.2 Type testing

5.1.2.1 Sampling

Where the ferrule design follows a mathematical progression throughout a given size range, rope diameter shall be selected for testing to represent the lower and upper quartiles of that range.

Where the ferrule design does not follow a mathematical progression throughout a given size range, each rope diameter within that range for which the system is designed shall be selected for testing.

For each rope diameter selected as above, the rope grade shall be the highest for which the system is designed and at least three FSETs or three ferrule secured endless loops, whichever is the case, shall be tested.

NOTE 1 In the case of the FSET the number of tests is regarded as two when the test lengths have a FSET at both ends.

Additionally, sampling shall take into account whether the type of ferrule-secured termination is a turn-back eye or Flemish eye or whether it is an endless loop, as follows:

a) Turn-back eye ferrule secured-termination

Testing shall be carried out on each of the basic rope types for which the system is designed. For each basic rope type, testing shall be carried out on ropes having the lowest and highest metallic cross-sectional area factors for which the system is designed.

NOTE 2 For the purposes of this standard there are four basic rope types, namely single layer rope, rotation-resistant rope, parallel-closed rope and spiral strand rope, refer EN 12385-2 for definitions.

b) Flemish-eye ferrule-secured termination

Testing shall be carried out on single layer rope having the lowest and highest metallic cross-sectional area factors for which the system is designed.

c) Ferrule-secured endless loop

Testing shall be carried out on single layer rope having the lowest and highest metallic cross-sectional factor for which the system is designed

5.1.2.2 Tensile test

When tested in accordance with 6.2 the FSET shall sustain a force of at least 90% of the minimum breaking force of the rope.

NOTE A terminal efficiency of 90% is equivalent to a termination efficiency factor, K_T , of 0,9 which is used in the calculation of WLL for slings

When tested in accordance with 6.2 the ferrule-secured endless loop shall sustain a force of at least 90% of twice the minimum breaking force of the rope.

5.1.2.3 Fatigue test

When tested in accordance with 6.3 for 75 000 cycles followed by a tensile test in accordance with 6.2 the FSET and endless loop shall sustain a force of at least 80% of the minimum breaking force of the rope.

Additionally for Flemish eye ferrule-secured terminations of crane hoist ropes a further fatigue test shall be performed on an assembly comprising a solid thimble having a peripheral length equivalent to at least four rope lay lengths. When tested in accordance with 6.4 the ferrule-secured termination shall withstand a minimum of 1×10^6 cycles and not exhibit a complete strand fracture.

5.1.3 Instructions to be provided by the ferrule-secured system designer

The ferrule-secured system designer shall provide instructions on at least the following:

- a) preparation of the rope end;
- b) details of the rope(s) for which the system is designed;
- c) matching of the ferrule material and size to the rope diameter and type;
- d) positioning of the rope end;
- e) procedure for ferrule-securing, i.e. pressing the ferrule;
- f) alignment, condition and maintenance of the tooling;
- g) procedure for removal of fins
- h) dimensional requirements of the pressed ferrule;
- i) marking limitations of the ferrule; and
- j) temperature limits of the ferrule secured system.

5.2 Ferrules

5.2.1 Material

The material selected by the ferrule manufacturer shall be non-alloy carbon steel or aluminium and shall conform to the same specification as that used by the ferrule-secured system designer when satisfying the type tests.

Non-alloy carbon steel shall be a fully-killed non-ageing normalized steel.

Aluminium shall be in condition F according to EN 515.

5.2.2 Dimensions

The dimensions of the ferrule shall be in accordance with those used by the ferrule-secured system designer when satisfying the type tests.

5.2.3 Manufacture and quality control of ferrule

The tube from which ferrules are made shall be free from any cracks, folds and surface defects.

With the exception of steel ferrules for Flemish eyes, ferrules shall be produced to provide a seam-free hollow product. Extrusion over mandrels with a bridge shall not be used. Electric resistance welding of steel tubes may only take place for flemish eyes and shall be carried out prior to the tube drawing and normalizing processes.

For each batch of steel ferrules produced from the same cast of steel and heat treatment a sample ferrule shall be selected and close flattened at ambient temperature, see figure 1. If the sample fails this test a further ten (10) or 3% of the batch of ferrules, whichever is the greater, shall be randomly selected, and all shall pass the flattening test otherwise the whole batch shall be rejected.

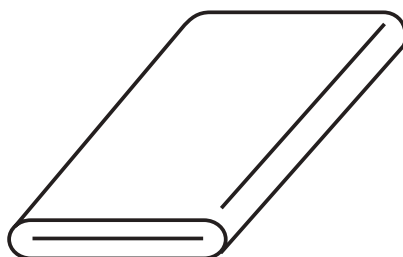

Figure 1 — Close-flattened ferrules

5.2.4 Certificate

The ferrule manufacturer shall supply a certificate stating that the whole batch of ferrules conforms to the ferrule secured system designer's specification.

5.2.5 Marking

Each ferrule shall be marked with its size and the ferrule manufacturer's name or mark except in the case of ferrules for use with ropes smaller than 8mm diameter where the marking can be on the package.

5.3 Ferrule-securing

5.3.1 General

The procedure adopted by the manufacturer of the ferrule-secured eye termination or endless loop shall be in accordance with 5.3.2 to 5.3.5 and the instructions provided by the ferrule-secured system designer.

Ferrule-securing shall be carried out by a competent person trained in ferrule-securing.

5.3.2 Matching of ferrule to wire rope

Determine the rope details from the documentation supplied with the rope, see EN 12385-1 and ensure that the rope is within the scope of the ferrule-secured system as detailed by the ferrule-secured system designer. In some cases it will also be necessary to determine the nominal metallic cross-sectional area factor of the rope, refer EN 12385 parts 4,5 & 10.

Follow the ferrule-secured system designer's instructions to select the appropriate ferrule size, taking into account the nominal or measured diameter of the rope, whichever is applicable.

5.3.3 Forming the eye

5.3.3.1 Flemish eye

The outer strands of the rope shall be divided into two equal groups. The core shall be assigned to one of these groups. The length of rope divided shall depend on the size of eye to be formed. Both groups of strands shall then be re-laid together in opposing directions, see figure 2.

No individual strands shall protrude from the rope in the eye.

The positioning of the strand ends and the removal or retention and placing of the core shall be in accordance with the ferrule-secured system designer's instructions (see 5.1.3).

When the ferrule is slid into position it shall not displace the strands. The strand ends shall be evenly distributed around the intact wire rope within the ferrule.

Positioning of the ferrule before pressing shall be such that the distance between the base of the thimble and the ferrule shall be "approximately" two times the nominal rope diameter after pressing. In the case of a thimble with a pointed end this distance shall be approximately 1,5 times the nominal rope diameter after pressing.

The peripheral length of a soft eye for a sling shall be at least four times the rope lay length.

The peripheral length of a soft eye for a crane hoist rope shall be at least six times the rope lay length.

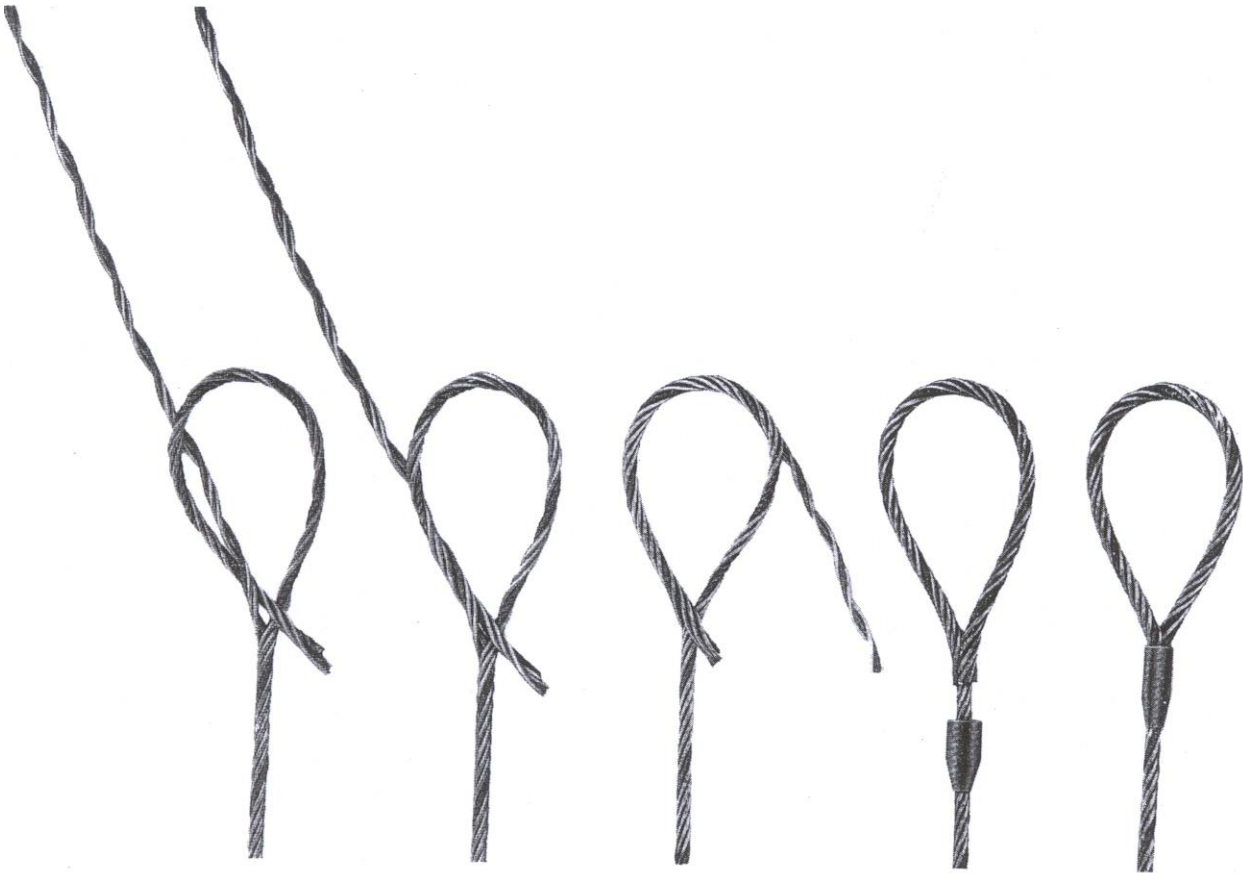

Figure 2 —Forming a Flemish eye

5.3.3.2 Turn-back eye

In the case of rope severed by a heat process the annealed length of rope shall not be greater than one rope diameter.

Rope secured by an oval ferrule with a tapered end shall not be severed by a heat process.

If a served rope end is to be pressed within the ferrule the serving shall consist only of a strand or wire. The serving material shall be of aluminium or annealed steel and shall have a tensile strength no greater than 400N/mm^2 . The diameter of the serving shall be no greater than 5% of the nominal rope diameter. Any serving within the ferrule before pressing shall be no longer than one half the nominal rope diameter and the overall length of serving shall extend no further than one rope diameter from the rope end.

The eye shall be formed by passing the rope end through the ferrule to form the required eye size and then by passing the end of the rope back through the ferrule.

In the case of rope severed by a heat process the annealed portion of the rope shall not be positioned within the ferrule.

The length (h) of a soft eye from the ferrule to the bearing point of the eye shall be at least fifteen (15) times the nominal rope diameter.

NOTE 1 The width ($h/2$) of the eye with the rope under no load should be approximately half of its length. see figure 3

In all other cases the rope end shall protrude by no more than one half of the rope diameter. In the case of ropes severed by a heat process the ferrule shall be positioned such that after pressing the rope end shall protrude from the ferrule by an amount no more than one rope diameter, i.e. only the annealed portion shall protrude.

Positioning of the ferrule before pressing shall ensure that the distance after pressing provides

- a) clearance between thimble and ferrule
- b) the thimble is secured within the eye (secured against the possibility of rotation within the eye or rolling out of the eye).

NOTE 2 Typically after pressing the clearance between the base of the thimble and the ferrule should be approximately of 1,5 times the nominal rope diameter for a thimble without a point, and 1 times the nominal diameter for a thimble with a point unless specified otherwise by a competent person. See informative annex A for a specification of one design of turnback eye ferrule-secured termination.

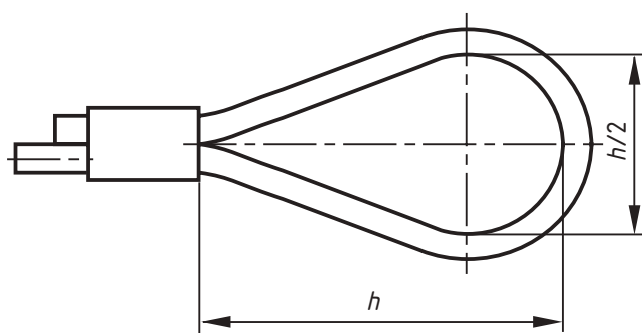

Figure 3 – Example of a turn-back eye

5.3.4 Pressing the ferrule

Pressing of the ferrule and removal of the fins shall be in accordance with the ferrule-secured system designer's instructions.

The contact and inner surfaces of the pressing tools shall be clean and lubricated.

The pressing tools shall not be mis-aligned.

In the case of a square ended oval ferrule the major axis of the ferrule shall coincide with the direction of pressing. At the end of the pressing operation the contact faces of the tools shall meet.

The position of the rope end shall be checked and shall be in accordance with the ferrule-secured system designer's instructions, taking into account the particular requirements for oval ferrules with tapered ends, see 5.1.

All fins resulting from the pressing operation shall be removed. Any fins shall not be pressed back into the ferrule.

NOTE Any difficulty in removing fins indicates excessive tool wear, in which case the condition of the tooling needs to be assessed.

5.3.5 Quality control after pressing of the ferrule

At each set-up of the pressing tools, the pressed ferrule shall be dimensionally checked to verify that it is within the pressed diameter and length limits specified by the ferrule-secured system designer.

Each pressed ferrule shall be checked for diameter to verify that it is within the diameter limits specified by the ferrule-secured system designer.

Each pressed ferrule shall be inspected to ensure that the ferrule is free from any flaws and surface defects.

For turn-back eyes the position of the tail end shall be checked to ensure compliance with the FSET system designer's instructions.

6 Verification of the safety requirements and/or measures

6.1 Qualification of personnel

Any person verifying the type testing, the ferrule, the FSET or ferrule-secured endless loop shall be a competent person.

6.2 Tensile type test (FSET system designer)

The applied force shall be transmitted by means of round pins, the diameter of which for the FSET shall be selected so that an included angle of taper between 25 and 35 degrees is subtended by the soft eye at the ferrule and for the ferrule secured endless loop shall be no less than four times the nominal diameter of the rope.

In the case of the ferrule-secured endless loop the ferrule-secured portion shall be positioned mid-way between the pins.

After 50 % of the minimum breaking force of the rope has been applied, additional force shall be applied at a rate of not more than 0,5 % of the minimum breaking force of the rope per second.

The minimum length of free rope between terminations shall be 30 times nominal rope diameter.

6.3 Fatigue type test (FSET system designer)

The test shall be carried out on an in-line tensile fatigue machine. The terminations shall not be allowed to rotate and the test shall consist of the application of a cyclic force from 15 % to 30 % of the minimum breaking force of the rope along the rope axis for 75 000 cycles.

The cyclical test frequency shall not exceed 5 Hz in an ambient temperature of 10 ° to 40 °C.

The tensile test which follows the tensile fatigue test shall be in accordance with 6.2.

6.4 Fatigue type test of Flemish eye ferrule-secured termination of crane hoist rope (FSET system designer)

The test shall be carried out on an in-line tensile fatigue machine. The terminations shall not be allowed to rotate and the test shall consist of the application of a cyclic force from 2,5 % to 20 % of the minimum breaking force of the rope along the rope axis.

The cyclical test frequency shall not exceed 5 Hz in an ambient temperature of 10 °C to 40 °C.

6.5 Ferrule dimensions before pressing (Ferrule manufacturer)

The requirements of 5.2.2 shall be confirmed by measurement.

6.6 Manufacture and quality control of ferrule (Ferrule manufacturer)

The material requirements of 5.2.1 shall be confirmed by visual inspection of the inspection document

The tube and ferrule extrusion requirements of 5.2.3 shall be confirmed by visual inspection.

6.7 Ferrules (FSET or ferrule-secured endless loop manufacturer)

Compliance with the ferrule requirements shall be through a visual verification of the inspection document supplied with the ferrule.

6.8 Matching of ferrule to wire rope (FSET or ferrule-secured endless loop manufacturer)

The requirements of 5.3.2 shall be confirmed by visual inspection of the documentation supplied with the rope and the instructions provided by the ferrule-secured system designer, and/or by measurement.

6.9 Forming the eye (FSET or ferrule-secured endless loop manufacturer)

The requirements of 5.3.3 shall be confirmed by visual inspection.

6.10 Pressing the ferrule (FSET or ferrule-secured endless loop manufacturer)

The requirements of 5.3.4 shall be confirmed by visual inspection.

6.11 Quality control after pressing the ferrule(s) (FSET or ferrule-secured endless loop manufacturer)

The set-up requirements shall be confirmed by measurement.

The manufacturing diameter requirements shall be confirmed by measurement or by the use of a “go/no go” gauge.

The requirements for flaws and defects and the position of the tail end in the turn-back eye shall be confirmed by visual inspection.

7 Information for use

7.1 Marking

If the FSET forms part of a wire rope assembly other than a sling:

- a) The ferrule shall be legibly and indelibly marked with the FSET manufacturer's name, symbol or mark; and
- b) The assembly shall be legibly and durably marked with the traceability code identifying the assembly with the certificate in 7.2.

NOTE The marking requirements for slings are given in 7.1 of EN 13414-1.

7.2 Certificate

If the FSET forms part of a wire rope assembly other than a sling the certificate shall include at least the following information:

- a) name and address of the FSET manufacturer or authorized representative, including the date of issue of the certificate and authentication;
- b) number and relevant part of this European standard;
- c) description of the assembly; and
- d) traceability code as per marking.

NOTE The certificate requirements for slings are given in 7.2 of EN 13414-1.

Annex A (informative)

Specification for one design of turn-back eye ferrule-secured termination

A.1 General

This annex states material, dimensional and manufacturing requirements for one design of turn-back eye ferrule-secured termination with an oval aluminium ferrule that meets the performance requirements of this part of EN 13411 when securing ropes having rope grades up to and including 1960.

NOTE Other turn-back eye ferrule-secured terminations may conform to this standard provided all of the stated requirements are satisfied.

A.2 Types of terminations

Terminations with thimbles are shown in Figure A.1a). The dimension d_1 applies only within the area indicated (120°) in Figure A1.b). There are to be no roundings or tapers on the loop end of the pressed ferrule.

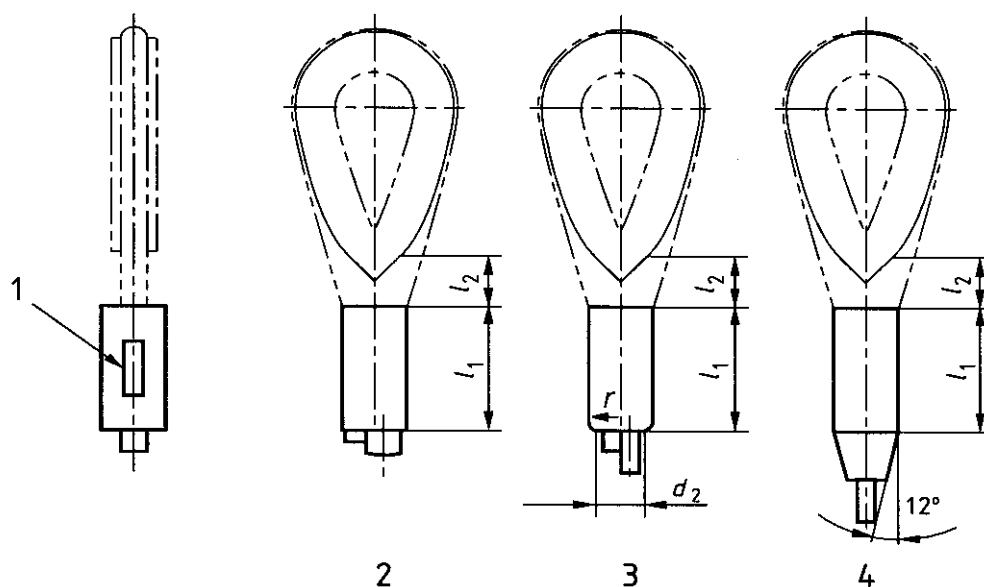
**Key**

1. Place for identification marking
2. Type A - cylindrical
3. Type B - cylindrical rounded
4. Type C - cylindrical conical
- a) Terminations with symbols.

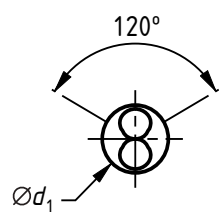
**Key**

- d_1 external pressed size
- The diameter d_1 applies only within the range of angle 120° .
- b) Cross-section through ferrule.

Figure A.1 — Types of pressed terminations (see table A.3 for dimensions)

A.3 Ropes for this design of ferrule

A.3.1 General

Ferrules conforming to this annex are suitable for making ferrule-secured terminations with ropes conforming to A.3.2, A.3.3 and A.3.4.

A.3.2 Rope types

Single layer, rotation-resistant and parallel-closed stranded ropes conforming to EN 12385-4, stranded ropes conforming to EN 12385-5, spiral strand ropes conforming to EN 12385-10 and cable-laid ropes as specified in EN 13414-3.

A.3.3 Metallic cross sectional area factor

The minimum metallic cross sectional area factor is to be 0,283.

A.3.4 Rope grade

The maximum rope grade is to be 1960.

A.3.5 Types of rope lay

Ordinary and Lang lay.

A.4 Tubing

A.4.1 General

Tubing blanks are to be of oval cross-section and constant wall thickness and are to comply with the tolerances in A.4.3, and A.4.4.

A.4.2 Material

Composition of the material is to conform to EN AW-ALMg2 (B) (EN AW-5051A) in accordance with EN 573-3 and have the following properties.

Hardness is to be 38 to 45 Brinell 2,5/31,25.

Tensile strength: $R_m \geq 145 \text{ N/mm}^2$

0,2 % proof stress: $R_p 0,2 \geq 50 \text{ N/mm}^2$

Elongation after fracture: $A_5 \geq 20 \%$

A.4.3 Straightness

Lengths of tubing (l_1) in excess of 300 mm are not to deviate (h_1) from the straight by more than 4 mm/m (h_1/l_1). In any length (l_1) lengths (l_2) less than 300 mm are not to deviate (h_2) from the straight by more than 2,5 mm. See Figure A.2.

Tubing for ferrules for ropes of 14 mm diameter and greater are not to exhibit a twist in excess of 2,5 mm/m.

Twists over the whole length of tubing are not to exceed 5 mm. See Figure A.3.

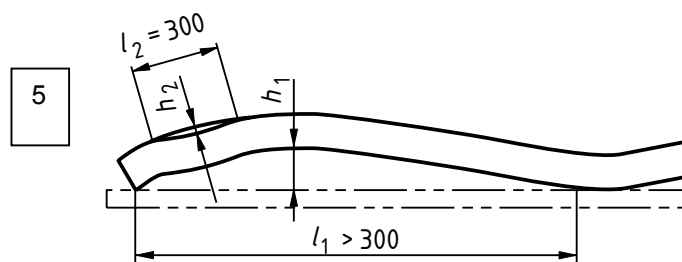
**Key**

l_1 length of the tubing

l_2 clearance between the base of the thimble and the ferrule

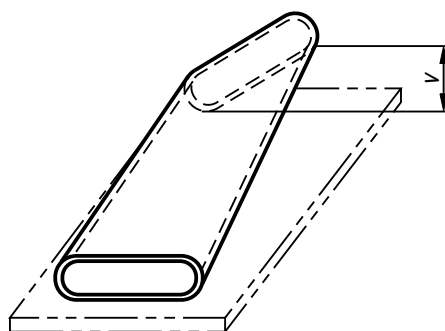
Figure A.2 — Straightness of tubing**Figure A.3 — Twist in tubing****A.4.4 Wall thickness**

The average actual wall thickness \bar{s} is to be determined as follows:-

$$\bar{s} = \frac{s_{\max} + s_{\min}}{2}$$

Deviation of wall thickness, which is defined by the following formula, is to be in accordance with table A.1.

$$u = s_{\max} - \bar{s} = \bar{s} - s_{\min}$$

A.5 Identification and dimensions of ferrules (unpressed)

Ferrules are to be identified by size number, see Table A.1.

Ferrules (type A) and round end ferrules (type B) are to be as shown in Figure A.4 a). Dimensions are to comply with Table A.1.

Ferrules with tapered end (type C) are to be as shown in figure A.4 b). Dimensions are to comply with Table A.1.

The exact shape of the tapered end of type C ferrules is to be at the discretion of the ferrule manufacturer.

NOTE The tapered end should be designed in such a way that it does not prevent the ferrule taking up a stable, horizontal position in the pressing tool before and during the pressing operation. The wall of the ferrule should be provided with an opening which will reveal the position of the dead end of rope in the completed ferrule-secured termination.

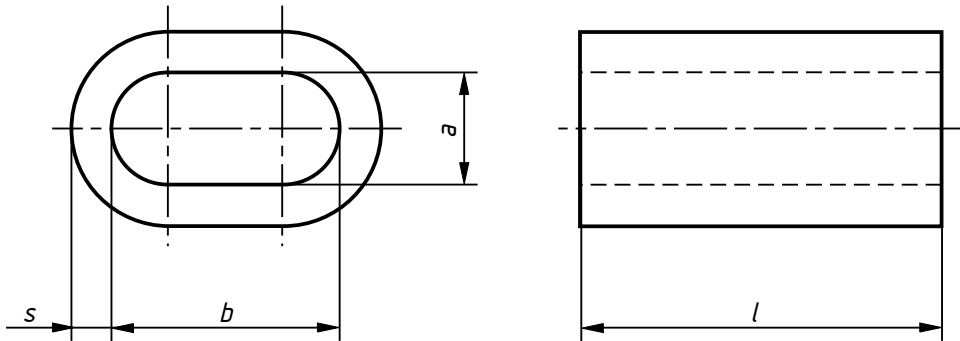

a) Types A and B cylindrical ferrule.

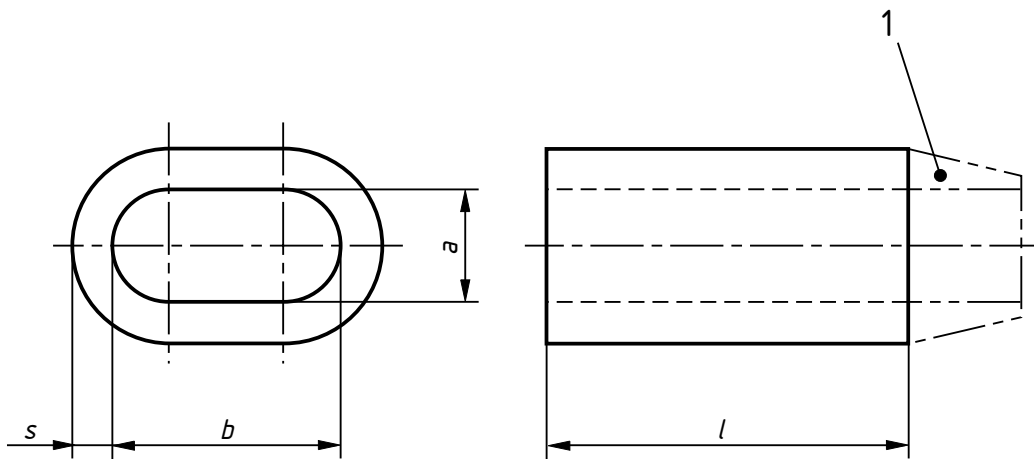

1 Tapered extension at the discretion of the manufacturer

b) Type C cylindrical ferrule with tapered end.

Figure A.4 — Ferrule dimensions (see table A.1)

Table A.1 — Dimensions of ferrule before pressing (see figure A.4)

Ferrule size number	Internal size				Wall thickness		Tolerable wall thickness difference u	Length		Nominal weight of 1000 pieces ¹⁾ kg
	a	tolerance	b	tolerance	s	$\bar{s} - s$		l	tolerance	
2,5	2,7	+ 0,2	5,4	+ 0,2	1,05	± 0,04	0,09	9	+ 0,2	0,499
3	3,3	0	6,6	0	1,25	± 0,04	0,12	11	- 0,5	0,843
3,5	3,8		7,6		1,5	± 0,05	0,13	13		1,32
4	4,4	+ 0,2	8,8	+ 0,2	1,7	± 0,05	0,15	14	+ 0,2	1,81
4,5	4,9	0	9,8	0	1,9	± 0,06	0,17	16	- 0,5	2,61
5	5,5		11,0		2,1	± 0,06	0,19	18		3,57
6	6,6		13,2		2,5	± 0,08	0,22	21	+ 0,2	5,86
6,5	7,2	± 0,15	14,4	± 0,15	2,7	± 0,08	0,24	23	- 0,5	7,55
7	7,8		15,6		2,9	± 0,09	0,26	25		9,53
8	8,8		17,6		3,3	± 0,10	0,29	28	+ 0,5	13,7
9	9,9	± 0,2	19,8	± 0,2	3,7	± 0,11	0,33	32	- 1	19,8
10	10,9		21,8		4,1	± 0,12	0,37	35		26,4
11	12,1		24,2		4,5	± 0,13	0,41	39	+ 0,5	35,8
12	13,2	± 0,3	26,4	± 0,3	4,9	± 0,15	0,44	42	- 1	45,8
13	14,2		28,4		5,4	± 0,16	0,48	46		59,7
14	15,3		30,6		5,8	± 0,17	0,52	49	+ 0,5	73,5
16	17,5	± 0,3	35	± 0,3	6,7	± 0,20	0,57	56	- 1	111
18	19,6		39,2		7,6	± 0,23	0,61	63		159
20	21,7	± 0,3	43,4	± 0,3	8,4	± 0,25	0,64	70	+ 0,7	217
22	24,3		48,6		9,2	± 0,28	0,67	77	- 1,5	292
24	26,4	± 0,4	52,8	± 0,4	10	± 0,30	0,70	84		376
26	28,5		57		10,9	± 0,32	0,74	91	+ 0,7	481
28	31	± 0,4	62	± 0,4	11,7	± 0,33	0,77	98	- 1,5	603
30	33,1		66,2		12,5	± 0,35	0,82	105		739
32	35,2		70,4		13,4	± 0,37	0,87	112	+ 0,7	897
34	37,8	± 0,4	75,6	± 0,4	14,2	± 0,38	0,92	119	- 1,5	1077
36	39,8		79,6		15	± 0,40	0,98	126		1275
38	41,9		83,8	± 0,4	15,8	± 0,41	1,03	133	+ 0,7	1503
40	44	± 0,4	88		16,6	± 0,43	1,08	140	- 1,5	1734
44	48,4		96,8	± 0,5	18,3	± 0,46	1,19	154		2314
48	52,8	± 0,4	105,6	± 0,5	20,0	± 0,5	1,3	168	+ 0,7	3010
52	57,2		114,4		21,6	± 0,54	1,4	182	- 1,5	3813
56	61,6	± 0,5	123,2	± 0,6	23,3	± 0,58	1,5	196		4772
60	66	± 0,5	132	± 0,6	25	± 0,63	1,6	210	+ 0,7	5880
									- 1,5	

¹⁾ Cylindrical ferrules, informative only

A.6 Matching wire rope to ferrule

Selection of the correct ferrule is to take account of:

- measured rope diameter;
- rope type (and core);
- nominal metallic cross-sectional area factor of the rope.

Case 1

For single layer round strand ropes with fibre core and cable-laid ropes having a metallic cross-sectional area factor C of at least 0,283, a ferrule having a size number equivalent to the nominal rope diameter is to be selected from Table A.2.

Case 2

For single layer round strand ropes with metallic core and for rotation-resistant round strand ropes having a metallic cross-sectional area factor up to 0,487, a ferrule having the next larger size number than the nominal rope diameter is to be selected from Table A.2.

Case 3

For single layer round strand ropes with metallic core and for rotation-resistant round strand ropes and parallel-closed round strand ropes having a metallic cross-sectional area factor greater than 0,487 and up to 0,613 the ferrule is to be selected from Table A.2.

Case 4

For spiral strand rope having a metallic cross-sectional area factor of at least 0,613, ferrules are to be selected having two size numbers larger than the nominal rope diameter, see table A.2. Two ferrules spaced two rope diameters apart are to be used per termination. After pressing a space is to be maintained between the ferrules.

Table A.2 – Ferrule size numbers

Rope diameter			Ferrule size number (see A.6)			
			Case 1	Case 2	Case 3	Case 4
Nominal <i>d</i> mm	Measured		single layer round strand ropes with FC and cable laid ropes $C \geq 0,283$	single layer round strand ropes with IWRC and rotation-resistant round strand ropes $C \leq 0,487$	single layer round strand ropes with IWRC, rotation-resistant ropes and parallel-closed ropes $0,487 < C \leq 0,613$	spiral strands 2 ferrules $C \geq 0,613$
	from mm	to mm				
2.5	2.5	2.7	2.5	3	-	-
3	2.8	3.2	3	3.5	-	-
3.5	3.3	3.7	3.5	4	-	-
4	3.8	4.3	4	4.5	-	5
4.5	4.4	4.8	4.5	5	-	6
5	4.9	5.4	5	6	-	6.5
6	5.5	5.9	6	6.5	-	7
	6	6.4			7	
6.5	6.5	6.9	6.5	7	8	8
7	7	7.4	7	8	9	9
8	7.5	7.9	8	9	9	10
	8	8.4			10	
9	8.5	8.9	9	10	10	11
	9	9.5			11	
10	9.6	9.9	10	11	11	12
	10	10.5			12	
11	10.6	10.9	11	12	12	13
	11	11.6			13	
12	11.7	11.9	12	13	13	14
	12	12.6			14	
13	12.7	12.9	13	14	14	16
	13	13.7			16	
14	13.8	13.9	14	16	16	18
	14	14.7			18	
16	14.8	15.9	16	18	18	20
	16	16.8			20	
18	16.9	17.9	18	20	20	22
	18	18.9			22	
20	19	19.9	20	22	22	24
	20	21			24	
22	21.1	21.9	22	24	24	26
	22	23.1			26	
24	23.2	23.9	24	26	26	28
	24	25.2			28	

Table A.2 – Ferrule size numbers (continued)

Rope diameter			Ferrule size number (see A.6)			
			Case 1	Case 2	Case 3	Case 4
Nominal <i>d</i> mm	Measured		single layer round strand ropes with FC and cable laid ropes $C \geq 0,283$	single layer round strand ropes with IWRC and rotation-resistant round strand ropes $C \leq 0,487$	single layer round strand ropes with IWRC, rotation-resistant ropes and parallel-closed ropes $0,487 < C \leq 0,613$	spiral strands 2 ferrules $C \geq 0,613$
	from mm	to mm				
26	25.3	25.9	26	28	28	30
	26	27.3			30	
28	27.4	27.9	28	30	30	32
	28	29.4			32	
30	29.5	29.9	30	32	32	34
	30	31.5			34	
32	31.6	31.9	32	34	34	36
	32	33.6			36	
34	33.7	33.9	34	36	36	38
	34	35.7			38	
36	35.8	35.9	36	38	38	40
	36	37.8			40	
38	37.9	37.9	38	40	40	44
	38	39.9			44	
40	40	42	40	44	48	48
44	42.1	43.9	44	48	48	48
	44	46.2			52	
48	46.3	47.9	48	52	52	52
	48	50.4			56	
52	50.5	51.9	52	56	56	60
	52	54.6			60	
56	54.7	55.9	56	60	-	-
	56	58.8			-	
60	58.9	59.9	60	-	-	-
	60	63		-		

A.7 Making the eye termination

A.7.1 Positioning of ferrule (Types A and B)

The ferrule is to be so positioned that after pressing the rope end protrudes from the ferrule. For ropes severed by a heat process the protrusion is to be up to one rope diameter. For all other cases the protrusion shall be up to one half a rope diameter.

The ferrule is to be so positioned that after pressing it is 1,5 times the nominal rope diameter from the base of a thimble (see Figure A.1). In the case of a thimble with a point the distance is to be 1 times the nominal rope diameter.

NOTE Before pressing, the ferrule may be fixed to the rope by slight deformation of the ferrule. Care needs to be taken to ensure that when deforming the ferrule, e.g. by hammering or in a vice, neither of the sides is dented; otherwise, during the subsequent pressing the ferrule could collapse (see Figure A.5).

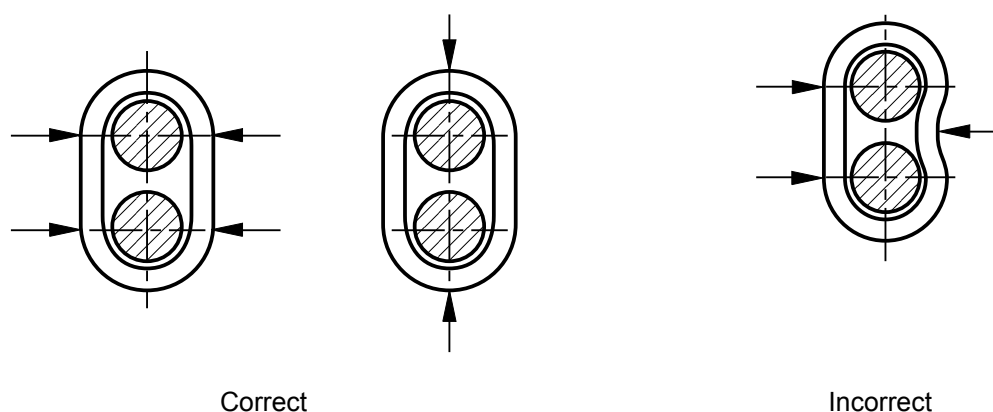

Figure A.4 — Fixing the ferrule on the rope

A.7.2 Pressing the ferrule

The ferrule is to be pressed only in a hydraulic or pneumatic press by means of cold working.

NOTE Ferrule sizes 2,5 to 5 may also be pressed using hand tools.

The ferrule is to be positioned in the pressing tool in a stable horizontal position.

The major axis of the oval ferrule cross-section shall align with the direction of pressing. On completion of the pressing operation the contact faces of the two parts of the pressing tools shall meet. The ferrule shall be pressed in one direction without turning. Any fins produced on the ferrule shall be removed without damage to the ferrule or the rope.

(See also 5.3.4.)

A.7.3 Ferrules after pressing

The dimensions of ferrules on pressed assemblies are to comply with Table A.3.

Table A.3 — Dimensions of pressed ferrules (see figure A.1)

Ferrule size number	External pressed size d_1		d_2 min mm	Parallel length $l_1^{(1)}$ mm	$l_2^{(1)}$ mm	$r^{(1)}$ mm
	nominal mm	tolerance mm				
2,5	5		-	12	3,75	-
3	6		-	14	4,5	-
3,5	7	+ 0,2	-	16	5,25	-
4	8	0	-	18	6	-
4,5	9		8	20	6,75	4,5
5	10		9	23	7,5	5
6	12		11	27	9	6
6,5	13		12	29	9,75	6,5
7	14	+ 0,4	13	32	10,5	7
8	16	0	14,5	36	12	8
9	18		16,5	40	13,5	9
10	20		18	45	15	10
11	22	+ 0,5	20	50	16,5	11
12	24	0	22	54	18	12
13	26		24	59	19,5	13
14	28	+ 0,7	25	63	21	14
16	32	0	29	72	24	16
18	36		32	81	27	18
20	40	+ 0,9	36	90	30	20
22	44	0	39	99	33	22
24	48		43	108	36	24
26	52	+ 1,1	46	117	39	26
28	56	0	50	126	42	28
30	60	+ 1,4	53	135	45	30
32	64	0	56	144	48	32
34	68		59	153	51	34
36	72		63	162	54	36
38	76	+ 1,6	66	171	57	38
40	80	0	69	180	60	40
44	88	+ 1,9	75	198	66	44
48	96	0	81	216	72	48
52	104	+ 2,1 0	87	234	78	52
56	112	+ 2,3 0	93	252	84	56
60	120	+ 2,4 0	99	270	90	60
¹⁾ Approximate dimensions						

A.8 Information for use

A.8.1 Identification marks

The ferrule is to be marked as indicated in Figure A.1-a.1 using stamp sizes given in Table A.4.

Table A.4 — Marking stamp sizes

Ferrule size number	Letter size	Depth of impression
	mm	mm
8 up to 24	3	0,5
above 24 up to 60	5	1

A.8.2 Temperature limits

The temperature limits when used with rope with a fibre core is – 40 °C to + 100 °C

The temperature limits when used with rope with a steel+ core is – 40 °C to + 150 °C

Annex ZA (informative)

Relationship of this European Standard with EU Directives

This European Standard has been prepared under a mandate given to CEN by the European Commission and the European Free Trade Association, and supports the essential requirements of EU Directives :

Machinery Directive 98/37/EC amended by Directive 98/97/EC

Compliance with this part and one of the other parts provides one means of conforming to the specific essential requirements of the Directive concerned.

WARNING: Other requirements and other EU Directives may be applicable to the product(s) falling within the scope of this standard.

Bibliography

EN 573-3, *Aluminium and aluminium alloys - Chemical composition and form of wrought products - Part 3: Chemical composition*

EN 1070, *Safety of machinery – Terminology*

EN 13414-1, *Steel wire rope slings - Safety - Part 1: Slings for general lifting service*

.....

BSI — British Standards Institution

BSI is the independent national body responsible for preparing British Standards. It presents the UK view on standards in Europe and at the international level. It is incorporated by Royal Charter.

Revisions

British Standards are updated by amendment or revision. Users of British Standards should make sure that they possess the latest amendments or editions.

It is the constant aim of BSI to improve the quality of our products and services. We would be grateful if anyone finding an inaccuracy or ambiguity while using this British Standard would inform the Secretary of the technical committee responsible, the identity of which can be found on the inside front cover.
Tel: +44 (0)20 8996 9000. Fax: +44 (0)20 8996 7400.

BSI offers members an individual updating service called PLUS which ensures that subscribers automatically receive the latest editions of standards.

Buying standards

Orders for all BSI, international and foreign standards publications should be addressed to Customer Services. Tel: +44 (0)20 8996 9001.
Fax: +44 (0)20 8996 7001. Email: orders@bsi-global.com. Standards are also available from the BSI website at <http://www.bsi-global.com>.

In response to orders for international standards, it is BSI policy to supply the BSI implementation of those that have been published as British Standards, unless otherwise requested.

Information on standards

BSI provides a wide range of information on national, European and international standards through its Library and its Technical Help to Exporters Service. Various BSI electronic information services are also available which give details on all its products and services. Contact the Information Centre.
Tel: +44 (0)20 8996 7111. Fax: +44 (0)20 8996 7048. Email: info@bsi-global.com.

Subscribing members of BSI are kept up to date with standards developments and receive substantial discounts on the purchase price of standards. For details of these and other benefits contact Membership Administration.
Tel: +44 (0)20 8996 7002. Fax: +44 (0)20 8996 7001.
Email: membership@bsi-global.com.

Information regarding online access to British Standards via British Standards Online can be found at <http://www.bsi-global.com/bsonline>.

Further information about BSI is available on the BSI website at <http://www.bsi-global.com>.

Copyright

Copyright subsists in all BSI publications. BSI also holds the copyright, in the UK, of the publications of the international standardization bodies. Except as permitted under the Copyright, Designs and Patents Act 1988 no extract may be reproduced, stored in a retrieval system or transmitted in any form or by any means – electronic, photocopying, recording or otherwise – without prior written permission from BSI.

This does not preclude the free use, in the course of implementing the standard, of necessary details such as symbols, and size, type or grade designations. If these details are to be used for any other purpose than implementation then the prior written permission of BSI must be obtained.

Details and advice can be obtained from the Copyright & Licensing Manager.
Tel: +44 (0)20 8996 7070. Fax: +44 (0)20 8996 7553.
Email: copyright@bsi-global.com.

BSI
389 Chiswick High Road
London
W4 4AL