

Terminations for steel wire ropes — Safety —

Part 1: Thimbles for steel wire rope slings

The European Standard EN 13411-1:2002 has the status of a
British Standard

ICS 53.020.30; 77.140.65

National foreword

This British Standard is the official English language version of EN 13411-1:2002. It supersedes BS 464:1958 which is withdrawn.

The UK participation in its preparation was entrusted to Technical Committee MHE/2, Wire ropes, which has the responsibility to:

- aid enquirers to understand the text;
- present to the responsible European committee any enquiries on the interpretation, or proposals for change, and keep the UK interests informed;
- monitor related international and European developments and promulgate them in the UK.

A list of organizations represented on this committee can be obtained on request to its secretary.

Cross-references

The British Standards which implement international or European publications referred to in this document may be found in the BSI Standards Catalogue under the section entitled “International Standards Correspondence Index”, or by using the “Find” facility of the BSI Standards Electronic Catalogue.

A British Standard does not purport to include all the necessary provisions of a contract. Users of British Standards are responsible for their correct application.

Compliance with a British Standard does not of itself confer immunity from legal obligations.

This British Standard, having been prepared under the direction of the Engineering Sector Policy and Strategy Committee, was published under the authority of the Standards Policy and Strategy Committee on 26 March 2002

Summary of pages

This document comprises a front cover, an inside front cover, the EN title page, pages 2 to 10, an inside back cover and a back cover.

The BSI copyright date displayed in this document indicates when the document was last issued.

Amendments issued since publication

Amd. No.	Date	Comments

EUROPEAN STANDARD

EN 13411-1

NORME EUROPÉENNE

EUROPÄISCHE NORM

February 2002

ICS 21.060.70; 53.020.30

English version

Terminations for steel wire ropes - Safety - Part 1: Thimbles for steel wire rope slings

Terminaisons pour câbles en acier - Sécurité - Partie 1:
Cosses pour élingues en câbles d'acier

Endverbindungen für Drahtseile aus Stahldraht - Sicherheit
- Teil 1: Kauschen für Anschlagseile aus Drahtseilen

This European Standard was approved by CEN on 11 November 2001.

CEN members are bound to comply with the CEN/CENELEC Internal Regulations which stipulate the conditions for giving this European Standard the status of a national standard without any alteration. Up-to-date lists and bibliographical references concerning such national standards may be obtained on application to the Management Centre or to any CEN member.

This European Standard exists in three official versions (English, French, German). A version in any other language made by translation under the responsibility of a CEN member into its own language and notified to the Management Centre has the same status as the official versions.

CEN members are the national standards bodies of Austria, Belgium, Czech Republic, Denmark, Finland, France, Germany, Greece, Iceland, Ireland, Italy, Luxembourg, Malta, Netherlands, Norway, Portugal, Spain, Sweden, Switzerland and United Kingdom.



EUROPEAN COMMITTEE FOR STANDARDIZATION
COMITÉ EUROPÉEN DE NORMALISATION
EUROPÄISCHES KOMITEE FÜR NORMUNG

Management Centre: rue de Stassart, 36 B-1050 Brussels

Contents

	page
Foreword	3
Introduction	4
1 Scope	4
2 Normative references	4
3 Terms and definitions	5
4 Hazards	5
5 Safety requirements and/or measures	5
6 Verification	7
7 Certificate	8
Annex ZA (informative) Relationship of this document with EC Directives	9
Bibliography	10

Foreword

This document EN 13411-1:2002 has been prepared by Technical Committee CEN/TC 168 "Chains, ropes, webbing slings and accessories" the secretariat of which is held by BSI.

This European Standard shall be given the status of a national standard, either by publication of an identical text or by endorsement, at the latest by August 2002, and conflicting national standards shall be withdrawn at the latest by August 2002.

This document has been prepared under a mandate given to CEN by the European Commission and the European Free Trade Association, and supports essential requirements of EC Directive(s).

For the relationship with EC Directives, see informative annex ZA which is an integral part of this document.

The other Parts of this European Standard are:

- Part 2: Splicing of eyes for steel wire rope slings
- Part 3: Ferrule secured eyes
- Part 4: Metal and resin socketing
- Part 5: Wire rope grips for eyes
- Part 6: Asymmetric wedge socket clevis
- Part 7: Symmetric wedge socket clevis

This is the first edition of this part of this European Standard.

According to the CEN/CENELEC Internal Regulations, the national standards organizations of the following countries are bound to implement this European Standard: Austria, Belgium, Czech Republic, Denmark, Finland, France, Germany, Greece, Iceland, Ireland, Italy, Luxembourg, Malta, Netherlands, Norway, Portugal, Spain, Sweden, Switzerland and the United Kingdom.

Introduction

This European Standard has been prepared to provide a means of conforming with the essential safety requirements of the Machinery Directive and associated EFTA regulations.

Purchasers ordering to this standard are advised to specify in their purchasing contract that the supplier operates a certified quality assurance system applicable to the relevant part of this standard (e.g. EN ISO 9001) to ensure themselves that products claiming to comply consistently achieve the required level of quality.

While producing this standard it was assumed that negotiation occurs between the manufacturer and the user to decide whether the thimble shall have a pointed or truncated end and whether zinc coating is required.

1 Scope

This European Standard specifies the minimum requirements for non welded general purpose steel thimbles produced from plate having dimensions in accordance with Figure 1. The thimbles are intended to be used in slings made with six or eight strand steel wire ropes from 8 mm to 60 mm diameter complying with EN 12385-4.

Reeving thimbles and solid thimbles are not covered by this standard.

The hazards covered by this standard are identified in clause 4.

2 Normative references

This European Standard incorporates by dated or undated reference, provisions from other publications. These normative references are cited at the appropriate places in the text, and the publications are listed hereafter. For dated references, subsequent amendments to or revisions of any of these publications apply to this European Standard only when incorporated in it by amendment or revision. For undated references the latest edition of the publication referred to applies (including amendments).

EN 292-2:1991/A1:1995, *Safety of machinery - Basic concepts, general principles for design - Part 2: Technical principles and specifications (Amendment 1:1995)*.

EN 1050:1996, *Safety of machinery - Principles for risk assessment*.

EN 10025, *Specification for hot rolled products of non-alloy structural steels - Technical delivery conditions (includes amendment A1:1993)*.

EN 12385-1:2002, *Steel wire ropes – Safety - Part 1: General requirements*.

prEN 12385-2, *Steel wire ropes – Safety - Part 2: Definitions, designation and classification*.

EN 12385-4:2002, *Steel wire ropes – Safety - Part 4: Stranded ropes for general lifting applications*.

3 Terms and definitions

For the purpose of this European Standard, the terms and definitions given in prEN 12385-2 together with the following apply.

3.1

nominal size (of a thimble)

size of the nominal diameter of the rope (d) for which the thimble has been primarily designed

4 Hazards

This clause contains the hazards and hazardous situations, as far as they are dealt with in this European Standard, identified by risk assessment significant for this type of machinery and which requires action to eliminate or reduce risk.

Accidental release of a load, or release of a load due to failure of a steel thimble puts at risk, either directly or indirectly, the safety or health of those persons within the danger zone.

In order to provide the necessary strength of steel thimble this standard gives requirements for the design, manufacture and testing to ensure the specified levels of performance are met.

Errors in the fitting of accessories can also lead to premature failure and this standard contains dimensional requirements to allow correct fit.

Table 1 contains all the hazards, which require action to reduce risk identified by risk assessment as being specific and significant for general purpose steel thimbles.

Table 1 - Hazards and associated requirements

Hazards identified in annex A of EN 1050:1996	Relevant clause of annex A of EN 292-2:1991/A1:1995	Relevant clause/subclause of this standard
1	Mechanical hazard	5
	due to inadequacy	5
	of strength	5
		5.4
10.4	Errors of fitting hazard	5.1 5.2

5 Safety requirements and/or measures

5.1 Dimensions

The dimensions of any size of thimble shall comply with Figure 1.

5.2 Material

The material from which the thimbles are to be formed shall be steel conforming to EN 10025.

NOTE If the thimble is surface coated with zinc, the amount should be at least 120 g/m^2 and should be applied in accordance with ISO 1461.

5.3 Construction

Thimbles shall be free from any flaws or defects.

NOTE 1 A small gap at the joint may be tolerated.

NOTE 2 There is no requirement regarding whether thimbles should be pointed or not (see Figure 1), and this should be subjected to agreement between the purchaser and the manufacturer, see introduction.

Thimbles shall be capable of being opened and closed once without the application of heat, wide enough to allow insertion of a component of 1,5 times the nominal rope diameter.

5.4 Type test

A type test shall demonstrate that the design, material and method of manufacture of the thimble having dimensions meeting the requirements of this standard can withstand the maximum loading conditions likely to be imposed upon it under normal conditions of use.

Any change, for example in the material specification, method of manufacture or critical dimensions, likely to effect the safety of the thimble, shall require that the type test in 6.1.2 be undertaken on the modified thimble.

After testing in accordance with 6.1.2 and with the load removed, any permanent reduction measured in dimension 1 of Figure 1 shall not exceed 15 % of its original value.

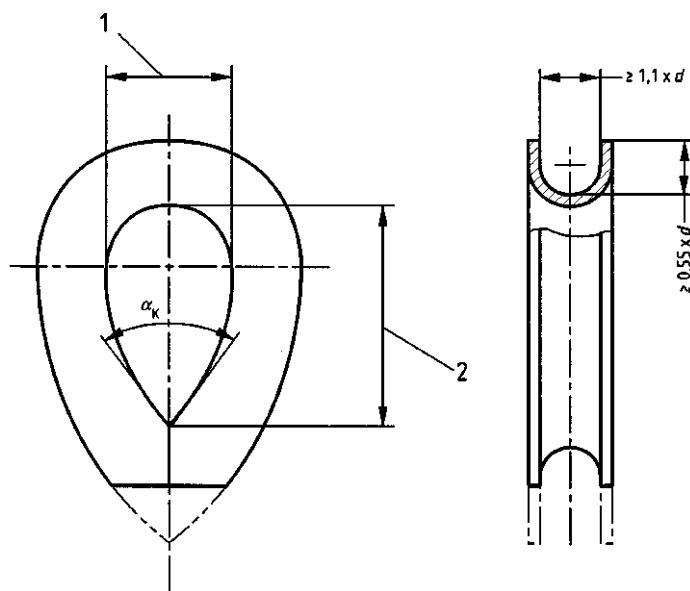

Key

1 $2,5$ to $3,5 \times d$

2 $1,5$ to $2 \times$ dimension 1

d = nominal rope diameter

$\alpha_k \leq 50^\circ$

Figure 1 - Thimble dimensions

6 Verification

6.1 Type test

6.1.1 Apparatus

6.1.1.1 Rope

The rope diameter shall be the same as the nominal size of the thimble. The rope construction shall be one from Table 6, 7, or 8 of EN 12385-4:2002 with a steel core. The rope grade shall be 1770.

6.1.1.2 Pin

The load shall be applied to the thimble through a pin having a diameter of $1,5 d$.

6.1.2 Method

The method of test shall be in accordance with 6.4.1 of EN 12385-1:2002.

Carry out two tests on each size of thimble of each design, material and method of manufacture.

Fit the thimble to a rope of the size specified in 6.1.1.1 and load it axially to 27 % of the minimum breaking force of the rope as given in EN 12385-4:2002.

After release of the test load measure dimension '1' of Figure 1 for any permanent reduction. The reduction shall not be greater than that specified in 5.4.

If any one thimble fails to pass, test a further two thimbles of the same size, design, material and method of manufacture. If these pass then the thimbles shall be deemed to have passed the type test.

If one or both fail the re-test or if both thimbles fail the original test, the thimbles shall be deemed to have failed the type test.

6.2 Dimensions

The linear dimensions of the thimble shall be measured with an instrument accurate to 0,1 mm and having a resolution of 0,01 mm. The measured dimension shall lie within the range specified in Figure 1. The angle shall be measured with an instrument accurate to 5° with a resolution of 1° .

6.3 Material

The suppliers records shall be used to verify the material used.

6.4 Construction

Thimbles shall be visually inspected for surface defects liable to injure the user or damage the rope.

7 Certificate

The manufacturer or supplier shall, on request, provide a certificate giving the following information:

- a) a statement of conformance to this European Standard;
- b) name and address of manufacturer;
- c) nominal size of thimble (rope diameter);
- d) a means of referencing the certificate to the thimble.

Annex ZA
(informative)

Relationship of this document with EC Directives

This document has been prepared under a mandate given to CEN by the European Commission and the European Free Trade Association and supports the essential requirements of EC Directive(s):

Machinery Directive 98/37/EC, amended by Directive 98/79/EC.

Compliance with this document provides one means of conforming with the specific essential requirements of the Directive concerned and associated EFTA regulations.

WARNING: Other requirements and other EC Directives may be applicable to the product(s) falling within the scope of this document.

Bibliography

ISO 1461, *Metallic coatings - Hot dip galvanized coatings on fabricated iron and steel articles – Specifications and test methods.*

ISO 6892, *Metallic materials - Tensile testing at ambient temperature.*

EN ISO 9001, *Quality management systems - Requirements (ISO 9001:2000).*

BSI — British Standards Institution

BSI is the independent national body responsible for preparing British Standards. It presents the UK view on standards in Europe and at the international level. It is incorporated by Royal Charter.

Revisions

British Standards are updated by amendment or revision. Users of British Standards should make sure that they possess the latest amendments or editions.

It is the constant aim of BSI to improve the quality of our products and services. We would be grateful if anyone finding an inaccuracy or ambiguity while using this British Standard would inform the Secretary of the technical committee responsible, the identity of which can be found on the inside front cover. Tel: +44 (0)20 8996 9000. Fax: +44 (0)20 8996 7400.

BSI offers members an individual updating service called PLUS which ensures that subscribers automatically receive the latest editions of standards.

Buying standards

Orders for all BSI, international and foreign standards publications should be addressed to Customer Services. Tel: +44 (0)20 8996 9001. Fax: +44 (0)20 8996 7001. Email: orders@bsi-global.com. Standards are also available from the BSI website at <http://www.bsi-global.com>.

In response to orders for international standards, it is BSI policy to supply the BSI implementation of those that have been published as British Standards, unless otherwise requested.

Information on standards

BSI provides a wide range of information on national, European and international standards through its Library and its Technical Help to Exporters Service. Various BSI electronic information services are also available which give details on all its products and services. Contact the Information Centre. Tel: +44 (0)20 8996 7111. Fax: +44 (0)20 8996 7048. Email: info@bsi-global.com.

Subscribing members of BSI are kept up to date with standards developments and receive substantial discounts on the purchase price of standards. For details of these and other benefits contact Membership Administration. Tel: +44 (0)20 8996 7002. Fax: +44 (0)20 8996 7001. Email: membership@bsi-global.com.

Information regarding online access to British Standards via British Standards Online can be found at <http://www.bsi-global.com/bsonline>.

Further information about BSI is available on the BSI website at <http://www.bsi-global.com>.

Copyright

Copyright subsists in all BSI publications. BSI also holds the copyright, in the UK, of the publications of the international standardization bodies. Except as permitted under the Copyright, Designs and Patents Act 1988 no extract may be reproduced, stored in a retrieval system or transmitted in any form or by any means – electronic, photocopying, recording or otherwise – without prior written permission from BSI.

This does not preclude the free use, in the course of implementing the standard, of necessary details such as symbols, and size, type or grade designations. If these details are to be used for any other purpose than implementation then the prior written permission of BSI must be obtained.

Details and advice can be obtained from the Copyright & Licensing Manager. Tel: +44 (0)20 8996 7070. Fax: +44 (0)20 8996 7553. Email: copyright@bsi-global.com.