

# Steel wire ropes — Safety —

## Part 3: Information for use and maintenance

The European Standard EN 12385-3:2004 has the status of a  
British Standard

ICS 77.140.65

## National foreword

This British Standard is the official English language version of EN 12385-3:2004. It, together with BS ISO 4309:2004, supersedes BS 6570:1986 which is withdrawn.

The UK participation in its preparation was entrusted to Technical Committee MHE/2, Wire ropes, which has the responsibility to:

- aid enquirers to understand the text;
- present to the responsible international/European committee any enquiries on the interpretation, or proposals for change, and keep the UK interests informed;
- monitor related international and European developments and promulgate them in the UK.

A list of organizations represented on this committee can be obtained on request to its secretary.

### Cross-references

The British Standards which implement international or European publications referred to in this document may be found in the *BSI Catalogue* under the section entitled "International Standards Correspondence Index", or by using the "Search" facility of the *BSI Electronic Catalogue* or of British Standards Online.

This publication does not purport to include all the necessary provisions of a contract. Users are responsible for its correct application.

**Compliance with a British Standard does not of itself confer immunity from legal obligations.**

This British Standard, was published under the authority of the Standards Policy and Strategy Committee on 29 September 2004

### Summary of pages

This document comprises a front cover, an inside front cover, the EN title page, pages 2 to 22, an inside back cover and a back cover.

The BSI copyright notice displayed in this document indicates when the document was last issued.

### Amendments issued since publication

Amd. No.	Date	Comments

© BSI 29 September 2004

ISBN 0 580 44524 0

EUROPEAN STANDARD

**EN 12385-3**

NORME EUROPÉENNE

EUROPÄISCHE NORM

September 2004

ICS 77.140.65

English version

## Steel wire ropes - Safety - Part 3: Information for use and maintenance

Câbles en acier - Sécurité - Partie 3 : Informations pour l'utilisation et la maintenance

Drahtseile aus Stahldraht - Sicherheit - Teil 3: Informationen für Gebrauch und Instandhaltung

This European Standard was approved by CEN on 22 July 2004.

CEN members are bound to comply with the CEN/CENELEC Internal Regulations which stipulate the conditions for giving this European Standard the status of a national standard without any alteration. Up-to-date lists and bibliographical references concerning such national standards may be obtained on application to the Central Secretariat or to any CEN member.

This European Standard exists in three official versions (English, French, German). A version in any other language made by translation under the responsibility of a CEN member into its own language and notified to the Central Secretariat has the same status as the official versions.

CEN members are the national standards bodies of Austria, Belgium, Cyprus, Czech Republic, Denmark, Estonia, Finland, France, Germany, Greece, Hungary, Iceland, Ireland, Italy, Latvia, Lithuania, Luxembourg, Malta, Netherlands, Norway, Poland, Portugal, Slovakia, Slovenia, Spain, Sweden, Switzerland and United Kingdom.



EUROPEAN COMMITTEE FOR STANDARDIZATION  
COMITÉ EUROPÉEN DE NORMALISATION  
EUROPÄISCHES KOMITEE FÜR NORMUNG

Management Centre: rue de Stassart, 36 B-1050 Brussels

## Contents

	page
Foreword.....	3
Introduction .....	4
1 Scope .....	5
2 Normative references .....	5
3 Terms and definitions .....	5
4 List of significant hazards .....	5
5 Safety instructions and information for use and maintenance .....	6
Annex A (informative) Example of general information for use and maintenance.....	7
Annex B (informative) Guidance on rope selection.....	13
Annex C (informative) Material health and safety information on steel wire rope and its component parts .....	18
Annex ZA (informative) Relationship between this European Standard and the Essential Requirements of EU Directive 98/37/EC and 95/16/EC .....	21
Bibliography .....	22

## Foreword

This document (EN 12385-3:2004) has been prepared by Technical Committee CEN/TC 168 "Chains, ropes, webbing, slings and accessories - Safety", the secretariat of which is held by BSI.

This European Standard shall be given the status of a national standard, either by publication of an identical text or by endorsement, at the latest by March 2005, and conflicting national standards shall be withdrawn at the latest by March 2005.

This document has been prepared under a mandate given to CEN by the European Commission and the European Free Trade Association, and supports essential requirements of EU Directive(s).

For relationship with EU Directive(s), see informative Annex ZA, which is an integral part of this document.

The other Parts of this European Standard are:

Part 1: General requirements

Part 2: Definitions, designation and classification

Part 4: Stranded ropes for general lifting applications

Part 5: Stranded ropes for lifts

Part 6: Stranded ropes for mine shafts

Part 7: Locked coil ropes for mine shafts

Part 8: Stranded hauling and carrying-hauling ropes for cableway installations designed to carry persons

Part 9: Locked coil carrying ropes for cableway installations designed to carry persons

Part 10: Spiral ropes for general structural applications

This is the first edition of this Part of this European Standard.

According to the CEN/CENELEC Internal Regulations, the national standards organizations of the following countries are bound to implement this European Standard: Austria, Belgium, Cyprus, Czech Republic, Denmark, Estonia, Finland, France, Germany, Greece, Hungary, Iceland, Ireland, Italy, Latvia, Lithuania, Luxembourg, Malta, Netherlands, Norway, Poland, Portugal, Slovakia, Slovenia, Spain, Sweden, Switzerland and United Kingdom.

## Introduction

This document is a type C standard as stated in EN 1070.

This document has been prepared to support the other Parts of this standard that concern themselves with the particular requirements for steel wire ropes to be used in specific applications.

The types of ropes concerned and the extent to which hazards are covered are indicated in the scope of this document.

When provisions of this type C standard are different from those which are stated in type A and B standards, the provisions of this type C standard take precedence over the provisions of the other standards, for information for use and maintenance according to the provisions of this type C standard.

## 1 Scope

This document specifies the type of information for use and maintenance of steel wire ropes to be provided by the rope manufacturer or to be included in the manufacturer's handbook that accompanies a machine, piece of equipment or installation of which the steel wire rope forms a part.

The particular hazards covered by this document are identified in clause 4.

For steel wire ropes conforming to Parts 8 and 9 used on cableway installations designed to carry persons, additional information for use and maintenance is given in prEN 12927-7.

For steel wire rope slings, specific information on use and maintenance is given in EN 13414-2.

This document is not applicable to steel wire ropes manufactured before the date of publication of this document by CEN.

## 2 Normative references

The following referenced documents are indispensable for the application of this document. For dated references, only the edition cited applies. For undated references, the latest edition of the referenced document (including any amendments) applies.

EN 1050:1996, *Safety of machinery — Principles for risk assessment.*

EN 1070:1998, *Safety of machinery – Terminology.*

EN 12385-2:2002, *Steel wire ropes — Safety — Part 2: Definitions, designation and classification.*

EN ISO 12100-2:2003, *Safety of machinery - Basic concepts, general principles for design - Part 2: Technical principles (ISO 12100-2:2003)*

## 3 Terms and definitions

For the purposes of this document, the terms and definitions given in EN 1070:1998, EN 12385-2:2002 and the following apply.

### 3.1

#### **inspection**

visual check on the condition of the rope to identify obvious damage or deterioration which might affect its fitness for use

### 3.2

#### **thorough examination**

visual examination carried out by a competent (trained and experienced) person, and where necessary, supplemented by other means, such as measurement or electro-magnetic non-destructive testing, in order to detect damage or deterioration which might affect the fitness for use of the rope

## 4 List of significant hazards

Table 1 contains all the significant hazards, hazardous situations and events, as far as they are dealt with in this standard, identified by risk assessment and which require action to eliminate or reduce the risk.

**Table 1 — Hazards and associated requirements**

Hazards identified in Annex A of EN 1050:1996	Relevant clause of Annex A of EN ISO 12100-2:2003	Relevant clause of this standard
Insufficient instructions for the user of the steel wire ropes and the machinery manufacturer	1.7.4 4.4.1	5

## **5 Safety instructions and information for use and maintenance**

### **5.1 General**

Information shall be provided on the subjects listed in 5.2 to 5.4.

### **5.2 Use and maintenance**

This information shall include temperature limits, use in exceptionally hazardous conditions, first use, handling and installation and maintenance.

An example of such information is given in Annex A.

### **5.3 Rope selection**

For stranded ropes this information shall include guidance on rope construction in relation to abrasion and wear, type of core in relation to crushing of the rope at the drum, wire finish in relation to corrosion, direction of lay and type in relation to direction of coiling, rotational characteristics in relation to use of a swivel and fleet angle effects.

An example of such information is given in Annex B.

### **5.4 Material health and safety information on steel wire rope and its component parts**

This information shall include details of all the individual materials that form part of the finished rope and general information relating to occupational protective measures, emergency medical procedures, safety (including any fire or explosion hazards) and disposal.

An example of such information is given in Annex C.



## Annex A (informative)

### Example of general information for use and maintenance

#### A.1 Limitations on use due to adverse environmental conditions

##### A.1.1 Temperature

###### A.1.1.1 Steel wire ropes made from carbon steel wires

Account should be taken of the maximum temperature that may be reached by the wire rope in service. An underestimation of the temperature involved can lead to a dangerous situation.

Stranded ropes with fibre cores or fibre centres can be used up to a maximum of 100 °C.

Stranded ropes with steel cores and spiral ropes (i.e. spiral strand and locked coil) can be used up to 200 °C although some de-rating of the working load limit is necessary, the amount being dependent upon the exposure time at high temperature and the diameter of the wires. For operating temperatures between 100 °C and 200 °C the loss in strength may be assumed to be 10 %.

For temperatures above 200 °C special lubricants may be necessary and greater losses in strength than stated above will need to be taken into account. The rope or machinery manufacturer should be contacted.

The strength of steel wire ropes will not be adversely affected by operating temperatures as low as – 40 °C and no reduction from the working load limit is necessary; however, rope performance may be reduced, depending upon the effectiveness of the rope lubricant at low temperatures.

When the rope is fitted with a termination, also refer to A.1.1.2.

###### A.1.1.2 Terminations

In addition to the limits stated above for rope, and unless otherwise specified by the rope manufacturer or the manufacturer of the machine, equipment or installation, the following operating temperatures must not be exceeded:

Turn-back eye with aluminium ferrule: 150 °C

Ferrule-secured eye with steel ferrule: 200 °C

Socket filled with a lead-based alloy: 80 °C

Socket filled with zinc or a zinc-based alloy: 120 °C

Socket filled with resin – refer to resin socketing system designer's instructions

##### A.1.2 Use in exceptionally hazardous conditions

In cases where exceptionally hazardous conditions are known to exist, e.g. offshore activities, the lifting of persons and potentially dangerous loads such as molten metals, corrosive materials or radio active materials a risk assessment should be carried out and the working load limit selected or adjusted accordingly.

## A.2 Before putting the rope into first use

### A.2.1 Inspecting the rope and documents

The rope should be unwrapped and examined immediately after delivery in order to check its identity and condition and to ensure that the rope and its termination(s), if any, are compatible with the machinery or equipment to which they are to be attached in service.

NOTE 1 If damage to the rope or its package is observed, this should be recorded on the delivery note.

The Certificate of conformity by the rope manufacturer should be kept in a safe place, e.g. with the crane handbook, for identification of the rope when carrying out periodic thorough examinations in service.

NOTE 2 The rope should not be used for lifting purposes without the user having a Certificate in his possession.

### A.2.2 Storing the rope

A clean, well-ventilated, dry, dust free, undercover location should be selected. The rope should be covered with waterproof material if it cannot be stored inside.

The rope should be stored and protected in such a manner that it will not be exposed to any accidental damage during the storage period or when placing the rope in, or taking it out of, storage.

The rope should be stored where it is not likely to be affected by chemical fumes, steam or any other corrosive agents.

If supplied on a reel, the reel should be rotated periodically during long periods of storage, particularly in warm environments, to prevent migration of the lubricant from the rope.

The rope should not be stored in areas subject to elevated temperatures as this may affect its future performance. In extreme cases its original as-manufactured breaking force could be severely reduced rendering it unfit for safe use.

The rope should not be allowed to make any direct contact with the floor and the reel should be so positioned that there is a flow of air under the reel.

NOTE Failure to ensure the above may result in the rope becoming contaminated with foreign matter and start the onset of corrosion even before the rope is put into service.

Preferably, the reel should be supported in an A-frame or cradle standing on ground which is capable of safely supporting the total mass of rope and reel.

The rope should be inspected periodically and, when necessary, a suitable rope dressing, which is compatible with the manufacturing lubricant, should be applied.

Any wet packaging, e.g. sackcloth, should be removed.

The rope marking should be checked to verify that it is legible and relates to the certificate.

When removing from store, the principle 'first in, first out' should be applied.

### **A.2.3 Checking the condition of rope related parts of the machine, equipment or installation**

Before installing the new rope, the condition and dimensions of rope related parts, e.g. drums, sheaves and rope guards, should be checked to verify that they are within the operating limits as specified by the original equipment manufacturer.

For ropes working on cranes the effective groove diameter should be at least 5 % above the nominal rope diameter. The groove diameter should be checked using a sheave gauge.

Sheaves should also be checked to ensure that they are free to rotate.

Under no circumstances should the actual rope diameter be greater than the pitch of the drum. In the case of multi-layer coiling, the relationship between the actual rope diameter and the pitch should be assessed.

When grooves become excessively worn, it may be possible to have them re-machined. Before doing so, the sheave or drum should be examined to determine if sufficient strength will remain in the underlying material supporting the rope after the machining has been carried out.

**NOTE** When grooves become worn and the rope is pinched at its sides, strand and wire movement is restricted and the ability of the rope to bend is reduced, thus affecting rope performance.

## **A.3 Handling and installing the rope**

### **A.3.1 General**

The procedure for installing the rope should be carried out in accordance with a detailed plan issued by the user of the steel wire rope.

The rope should be checked to verify that it is not damaged when unloaded and when transported to storage compound or site. During these operations, the rope itself should not come into contact with any part of the lifting device, such as the hook of a crane or a fork of a fork lift truck. Webbing slings may be helpful.

### **A.3.2 Rope supplied in a coil**

The coil of rope should be placed on the ground and rolled out straight, ensuring that it does not become contaminated with dust, grit, moisture or other harmful material.

The rope should never be pulled away from a stationary coil as this will induce turn into the rope and form kinks.

If the coil is too large to physically handle it may need to be placed on a turntable which will allow the rope to be paid out as the end of the rope is pulled away from the coil. Correct methods of paying out rope from a coil are shown in Figure A.1.

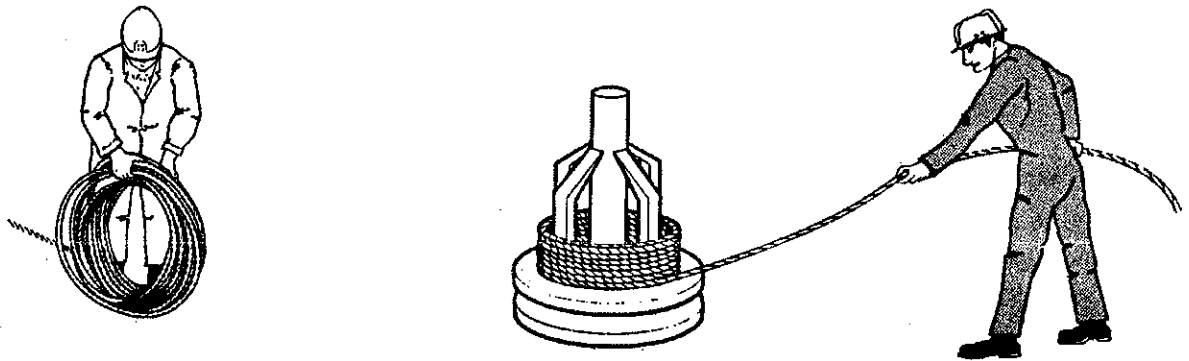

Figure A.1 — Correct methods of paying out rope from a coil

### A.3.3 Rope supplied on a reel

A shaft of adequate strength should be passed through the reel bore and the reel placed in a suitable stand which allows it to rotate and be braked to avoid overrun during installation.

Where multi-layer coiling is involved the rope should be placed in equipment that has the capability of providing a back tension in the rope as it is being transferred from the supply reel to the drum. This is to ensure that the underlying laps of rope, particularly in the bottom layer, are wound tightly on the drum.

The supply reel should be positioned such that the fleet angle during installation is kept to a minimum.

If a loop forms in the rope it should not be allowed to tighten to form a kink.

The reel stand should be mounted so as not to create a reverse bend during reeving, i.e. for a drum with an underwind rope, take the rope off the bottom of the supply reel (see Figure A.2).

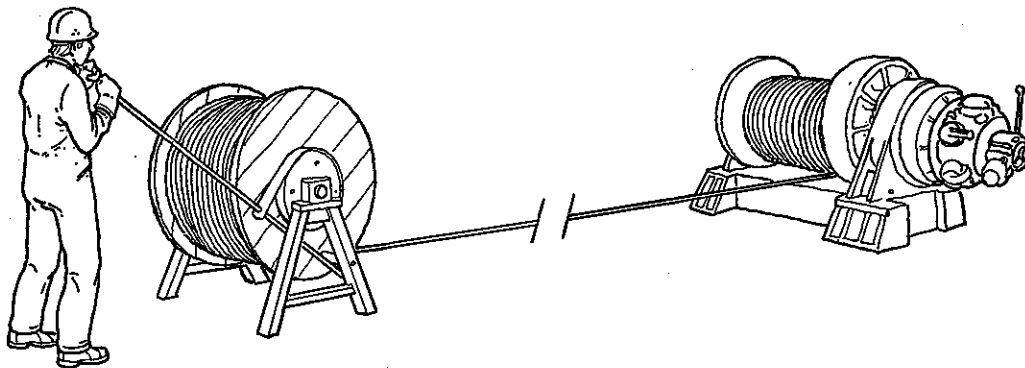

Figure A.2 – Transfer of wire rope from reel to drum with control of rope tension – bottom of reel to bottom of drum

When releasing the outboard end of the rope from the supply reel or coil, this should be done in a controlled manner. On release of the bindings or the rope end fixing, the rope will want to straighten itself and unless controlled this could be a violent action, which could result in injury.

The as-manufactured condition of the rope should be maintained during installation.

If installing the new rope with the aid of the old rope, one method is to fit a wire rope sock to each of the rope ends to be attached. The open end of the sock should be securely attached to the rope by a serving or alternatively by a suitable clip. The two ends should be connected via a length of fibre rope of adequate strength in order to avoid turn being transmitted from the old rope into the new rope. If a wire rope is used, it should be a rotation-resistant

type or should have the same lay type and direction as the new rope. Alternatively, a length of fibre or steel rope of adequate strength may be reeved into the system for use as a pilot/messenger line. A swivel should not be used during the installation of the rope.

Monitor the rope carefully as it is being pulled into the system and ensure that it is not obstructed by any part of the structure or mechanism that may damage the rope and result in a loss of control.

### A.3.4 Cutting the rope

If it is necessary to cut the rope, secure servings should be applied on both sides of the cut mark. The length of each serving for a stranded rope should be at least equal to two rope diameters.

One serving either side of the cut mark is usually sufficient for preformed ropes (see EN 12385-2). For non-preformed ropes, rotation-resistant ropes and parallel-closed ropes a minimum of two servings each side of the cut mark is recommended.

Preferably, cutting of the rope should be done using a high speed abrasive disc cutter. Other suitable mechanical or hydraulic shearing equipment may be used although not recommended when the rope end is to be welded or brazed. When cutting, ensure adequate ventilation to avoid any build-up of fumes from the rope and its constituent parts. See Annex C.

**NOTE 1** Some special ropes contain synthetic material which, when heated to a temperature higher than normal production processing temperatures, will decompose and may give off toxic fumes.

**NOTE 2** Rope produced from carbon steel wires in the form as-shipped is not considered a health hazard. During subsequent processing (e.g. cutting, welding, grinding, cleaning) dust and fumes may be produced which contain elements that may affect exposed persons.

After cutting, failure to correctly secure the rope end is likely to lead to slackness or distortions in the rope.

An alternative method of cutting is by fusing and tapering, a process which is designed to prevent the wires and strands from unlaying.

### A.3.5 'Running in' the new rope

Where possible, 'run in' the new rope by operating the equipment slowly, preferably with a low load for a number of cycles. This enables the new rope to adjust itself gradually to the working conditions. The rope should never 'run in' with full load or even with overload.

Check that the rope is spooling correctly on the drum and that no slack occurs in the rope or cross-laps of rope develop at the drum.

**NOTE** Irregular coiling will inevitably result in severe surface wear and rope distortion.

## A.4 Maintenance

### A.4.1 Inspecting and examining the rope

Inspection and through examination intervals and discard criteria should be in accordance with the following:

Crane ropes – ISO 4309;

Lift ropes – ISO/FDIS 4344;

Cableway ropes – prEN 12927-7.

#### A.4.2 Lubricating the rope in service

The protection provided by the original manufacturing lubricant is normally adequate to prevent deterioration due to corrosion during shipment, storage and the early life of the rope; however, in order to obtain optimum performance, most ropes will benefit from the application of a service lubricant, the type of which will be dependent upon the rope application and the environmental conditions to which the rope is exposed.

The service lubricant must be compatible with the original manufacturing lubricant and in the case of a traction drive rope, not impair its frictional characteristics. Refer to the recommendations of the rope manufacturer or the original equipment manufacturer.

Typical methods of applying the service lubricant are by brush, drip feed, portable pressurised spray or high pressure. This latter system is generally designed to force the service lubricant into the rope under high pressure while simultaneously cleaning the rope and removing moisture, residual lubricant and other contaminants.

Failure to apply a service lubricant could result in a reduction in the performance of the rope and at worst, lead to undetectable internal corrosion.

Application of too much and the wrong type of lubricant may lead to an accumulation of foreign debris on the surface of the rope. This could result in abrasive damage to the rope, the sheave and the drum. It may also make it difficult to determine the true condition of the rope for evaluation against discard criteria.

## Annex B (informative)

### Guidance on rope selection

#### B.1 Rope selection

##### B.1.1 Construction in relation to abrasion and wear

Wire rope will become progressively weaker when subject to abrasion and wear. This occurs when a rope makes contact with another body, such as when it passes through a sheave or over a roller, coils onto a drum or is dragged through or along abrasive material.

Where abrasion is known to be the primary mode of deterioration, consideration should be given to selecting a rope with as larger outer wires as possible, but also taking into account whether there is any additional need to fulfil any bending fatigue requirements.

Lang lay rope (subject to both ends of the rope being fixed and prevented from rotating) and compacted strand rope can be advantageous under abrasive conditions.

**NOTE** Although expected to occur mainly on the crowns of the wires, wear may also take place at the strand-core and strand interfaces within the rope.

##### B.1.2 Type of core in relation to crushing of the rope at the drum

Crushing can occur due to a number of reasons but more likely when the rope is subject to multi-layer coiling at the drum. Also, greater radial pressure will be experienced between the rope and a smooth or plain-faced drum than with a grooved drum.

Stranded ropes containing fibre should not be used where coiling extends into multi-layers.

Ropes with steel cores and compacted strand ropes are more resistant to crushing and distortion.

##### B.1.3 Wire finish in relation to corrosion

If corrosion is expected or known to be a primary mode of deterioration, it is preferable to use a rope containing zinc (or zinc alloy Zn95/Al5) coated wires.

Consideration should be given to selecting a rope with as larger wires as possible, taking into account whether there is any additional need to fulfil any bending fatigue requirements.

A rope with a large number of small wires is more susceptible to corrosion than a rope with a small number of large wires.

**B.1.4 Direction of lay and type**

**B.1.4.1 Connecting ropes to each other (in series) or working alongside each other (in parallel)**

In the event that it is necessary to connect one rope to another (i.e. in series), whether during installation or in operation, it is essential that they are of the same lay direction and type, e.g. right lay ordinary (sZ) to right lay ordinary (sZ).

NOTE Connecting a 'left' lay rope to a 'right' lay rope will result in rope rotation and unlaying of the strands when loaded. If the ropes are also hand spliced at the connection the splices will open up and pull apart.

Some applications, e.g. grabs and container cranes, demand the use of a left lay rope operating alongside a right lay rope (i.e. in parallel) in order to balance out the rotational effects of the two ropes.

**B.1.4.2 Direction of coiling**

Unless specified otherwise in the original equipment manufacturer's instructions, the direction of coiling should be in accordance with Figure B.1.

The direction of coiling in Figure B.1 generally applies to both smooth and grooved drums.

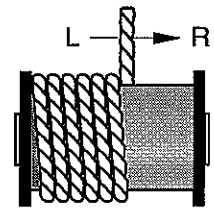
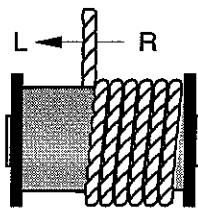

Start rope at right hand flange for right hand lay rope.

Start rope at left hand flange for left hand lay rope.

**Figure B.1 a —Right hand lay rope – underwind**

**Figure B.1 b —Left hand lay rope – underwind**

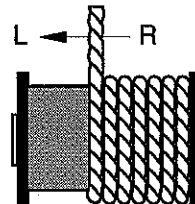
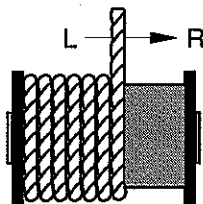

Start rope at left hand flange for right hand lay rope.

Start rope at right hand flange for left hand lay rope.

**Figure B.1 c —Right hand lay rope – overwind**

**Figure B.1 d —Left hand lay rope – overwind**

**Figure B.1 — Direction of coiling**



### B.1.5 Rotational characteristics and use of a swivel

'Cabling' of hoist ropes in a multi-part (fall) reeving arrangement due to block rotation can occur if the rope selected has inferior torsional properties for the intended height of lift, rope spacing and loading. In such cases lifting can be severely limited or even halted. Applications involving high lifts are particularly vulnerable to this condition.

**NOTE** Cabling is a term used to describe the condition in a multi-fall reeving arrangement where the falls of rope become untangled as they wrap around themselves.

When taking the torsional property of a rope into account the probability of cabling for a given reeving system can be assessed. Refer to the rope manufacturer or the original equipment manufacturer.

With rotation-resistant ropes where the outer strands are generally laid in the opposite direction to those of the underlying layer, (i) the amount of torque generated under load when both ends of the rope are fixed and prevented from rotating or (ii) the amount of rotation under load when one end of the rope is free to rotate, will be expected to be far less than that which would be experienced with single layer ropes.

To limit the hazard of a rotating load during a lifting operation and to ensure the safety of personnel within the lifting zone, it is preferable to select a rotation-resistant rope that will only rotate a small amount when loaded, see a) below. With such ropes, the usefulness of a swivel is to relieve the rope of any induced rotation resulting from angular deflections at a sheave or drum.

Other rotation-resistant ropes, having less resistance to rotation when loaded, see b) below, are likely to require the assistance of a swivel to minimise the hazard. In such cases, however, it should be recognised that excessive rope rotation can have an adverse affect on rope performance and can also result in a reduction in breaking force of the rope, the amounts of which will depend on the rotational property of the selected rope and the magnitude of the load being lifted.

The following is a summary of general guidance on the use of a swivel based on the rotational property of the rope:

- a) rotational property less than or equal to 1 turn/1 000*d* lifting a load equivalent to 20 %  $F_{min}$  - a swivel can be used;
- b) rotational property greater than 1 turn but no greater than 4 turns/1 000*d* lifting a load equivalent to 20 %  $F_{min}$  - a swivel may be used subject to the recommendations of the rope manufacturer and/or approval of a competent person;
- c) rotational property greater than 4 turns/1 000*d* at a load equivalent to 20 %  $F_{min}$  - a swivel should not be used,

where

1 turn = 360°;

$d$  = nominal rope diameter;

$F_{min}$  = minimum breaking force of rope.

### B.1.6 Fleet angle

Figure B.2 shows a helically grooved wide drum with a pitch angle  $\alpha$  and a deflection sheave. When the rope is coiling towards the flanges of the drum it will be deflected at the sheave by a fleet angle  $\beta_{\text{left}}$  or  $\beta_{\text{right}}$ . On the drum, it will be deflected by an angle  $(\beta_{\text{left}} + \alpha)$  or  $(\beta_{\text{right}} - \alpha)$ .

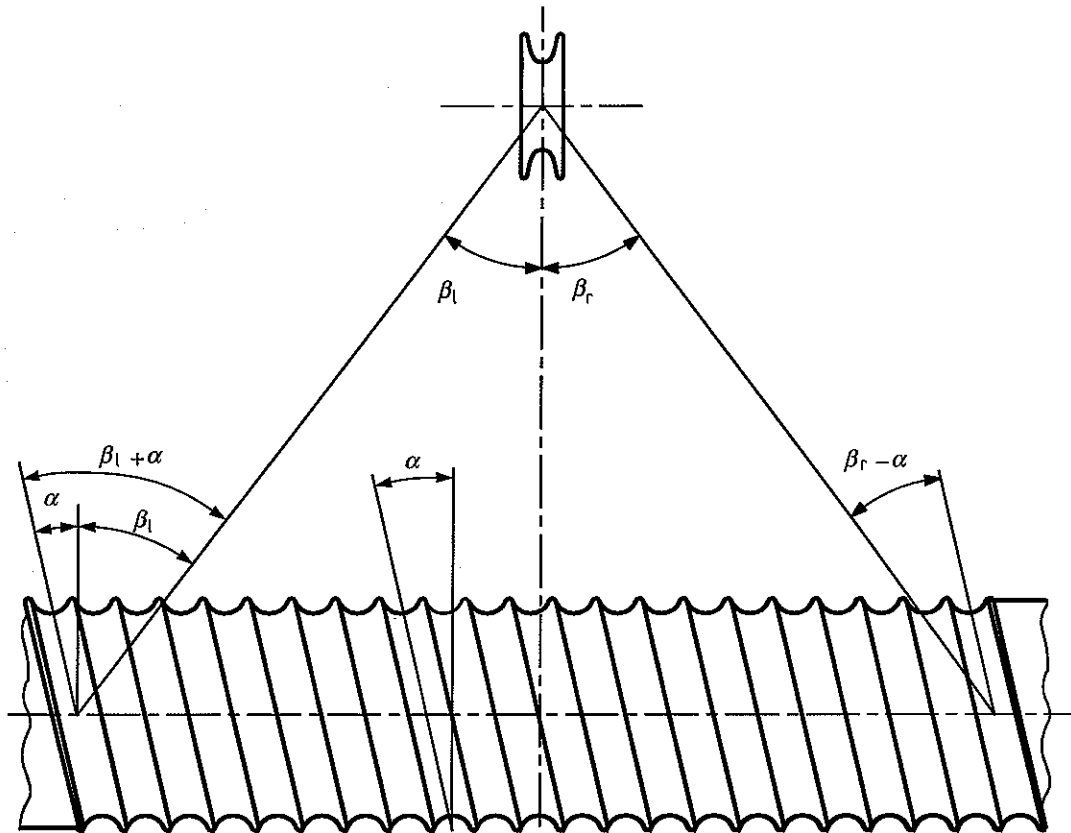

#### Key

- l left
- r right

Figure B.2 — Fleet and groove angles

Where a fleet angle exists as the rope enters a sheave, it initially makes contact with the flange of the groove. As the rope continues to pass over the sheave it moves down the flange until it sits in the bottom of the sheave groove. In doing so the rope will roll as well as slide, see Figure B.3. As a result of the rolling action the rope will rotate about its own axis causing turn to be induced into or taken out of the rope, either shortening or lengthening the rope lay, resulting in a reduction in fatigue performance and, in the worst case, structural damage to the rope in the form of a 'birdcage' or core protrusion. As the fleet angle increases so does the amount of rotation.

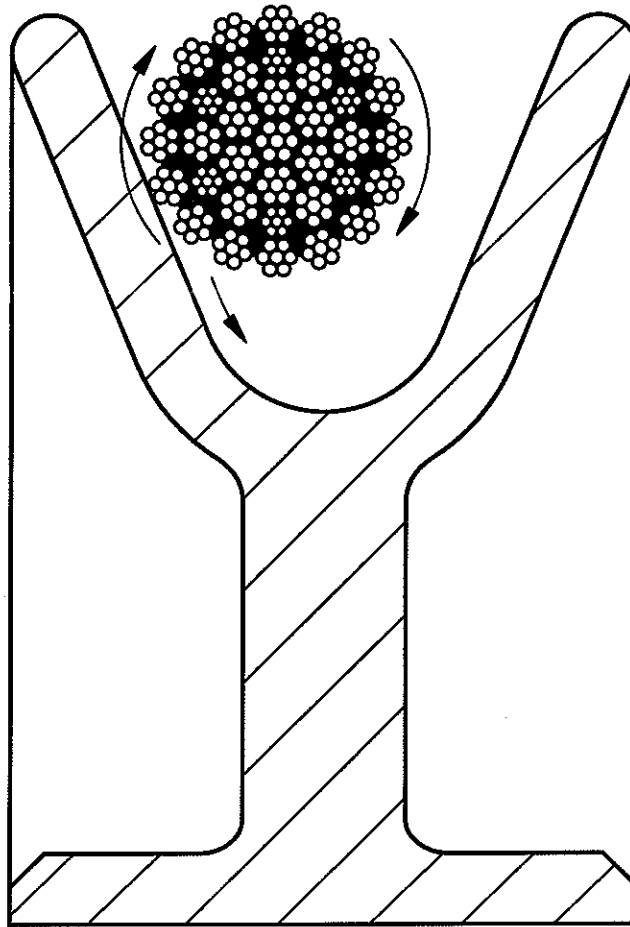

**Figure B.3 — Twisting of a rope resulting from the fleet angle**

The fleet angle should be no greater than  $2^\circ$  for rotation-resistant ropes and no greater than  $4^\circ$  for single layer ropes.

**NOTE** For practical reasons, the design of some cranes and hoists may be unable to meet these recommended values, in which case the rope life may be affected and the rope may need to be examined more frequently.

Fleet angles can be reduced by, for example:

- a) decreasing the drum width and/or increasing the drum diameter; or
- b) increasing the distance between the sheave and the drum.

When spooling onto a drum it is generally recommended that the fleet angle is limited to between  $0,5^\circ$  and  $2,5^\circ$ . If the angle is too small, i.e. less than  $0,5^\circ$ , the rope will tend to pile up at the flange of the drum and fail to return across the drum in the opposite direction. In this situation the problem may be alleviated by fitting a 'kicker' device or by increasing the fleet angle through the introduction of a sheave or spooling mechanism.

If the rope is allowed to pile up it will suddenly roll away from the flange creating a shock load in the rope.

Excessively high fleet angles will return the rope across the drum prematurely, creating gaps between wraps of rope close to the flanges of the drum as well as increasing the pressure on the rope at the cross-over positions.

Even where helical grooving is provided, large fleet angles will inevitably result in localised areas of mechanical damage as the wires 'pluck' against each other. This is often referred to as rope 'interference' but the amount can be reduced by selecting a lang lay rope if the reeving allows or a compacted strand rope.

## Annex C (informative)

### Material health and safety information on steel wire rope and its component parts

#### C.1 Material

##### C.1.1 General

Steel wire rope is a composite material and dependent upon its type may contain a number of discrete materials. The following provides details of all the individual materials that may form part of the finished rope.

The description and/or designation of the wire rope stated on the delivery note, invoice or certificate will enable identification of the component parts.

The main component of steel wire ropes covered by the various parts of EN 12385 is carbon steel, which may, in some cases, be coated with zinc or zinc alloy Zn95/Al5.

Rope produced from carbon, coated or stainless steel wires in the as-supplied condition is not considered a health hazard. However, during any subsequent processing such as cutting, welding, grinding and cleaning, dust and fumes may be produced which contain elements that may affect the health of exposed workers.

The other three components are the core, which may be of steel of the same type as used in the outer strands or, alternatively, fibre, either natural or synthetic; the rope lubricant(s); and, where applicable, any internal filling or external covering.

##### C.1.2 Fibre cores:

Being in the centre of a stranded steel wire rope, the materials from which fibre cores are produced, usually natural or synthetic fibres, do not present a health hazard when handled. Even when the outer strands are removed (for example when the rope is being socketed) the core materials present virtually no hazard to the user, except, maybe, in the case of a used rope where, in the absence of the application of any service lubricant or as a result of heavy working causing internal abrasive wear of the core, the core may have decomposed into a fibre dust which may be inhaled, although this is considered extremely unlikely.

The principal hazard is through inhalation of fumes generated by heat, for example when the rope is being cut by a disc cutter. Under these conditions, natural fibres are likely to yield carbon dioxide, water and ash, whereas synthetic materials are likely to yield toxic fumes.

The treatment of natural fibres, such as rot-proofing, may also produce toxic fumes on burning.

The concentration of toxic fumes from the cores will be almost negligible compared with the products generated by heating from other primary materials, e.g. wire and manufacturing lubricant in the rope.

The most common synthetic core material is polypropylene, although other polymers such as polyethylene and polyamide may occasionally be used.

##### C.1.3 Filling and covering materials:

Filling and covering materials do not present a health hazard during handling of the rope in its as-supplied condition. The principal hazard is by the inhalation of toxic fumes when the rope is being cut by a disc cutter.

#### C.1.4 Manufacturing rope lubricants:

The lubricants used in the manufacture of steel wire ropes normally present minimal hazard to the user in the as-supplied condition. The user should, however, take reasonable care to minimise skin and eye contact and also avoid breathing their vapours and mists.

A wide range of compounds is used as lubricants in the manufacture of steel wire rope. These products, in the main, consist of mixtures of oils, waxes, bitumens, resins, gelling agents and fillers with minor concentrations of corrosion inhibitors, oxidation stabilizers and tackiness additives.

Most of them are solid at ambient temperature and provided skin contact with the fluid types is avoided, none present a hazard in normal rope usage.

To avoid the possibility of skin disorders, repeated or prolonged contact with mineral or synthetic hydrocarbons should be avoided and it is essential that all persons who come into contact with such products maintain high standards of personal hygiene.

The worker should:

- a) use oil impermeable gloves;
- b) avoid unnecessary contact by oil by wearing protective clothing;
- c) obtain first aid treatment for any injury, however slight;
- d) wash hands thoroughly before meals, before using the toilet and after work; and
- e) use conditioning cream after washing, where provided.

The worker should not:

- f) put oily rags or tools into pockets, especially trousers;
- g) use dirty or spoiled rags for wiping oil from the skin;
- h) wear oil soaked clothing;
- i) use solvents such as paraffin, petrol, etc. to remove oil from the skin.

## C.2 General information

### C.2.1 Occupational protective measures:

a) Respiratory protection

General and local exhaust ventilation should be used to keep airborne dust or fumes below established occupational exposure standards (OES's).

Operators should wear approved dust and fume respirators if OES's are exceeded. (The OES for total dust is  $10 \text{ mg/m}^3$  and for respirable dust is  $5 \text{ mg/m}^3$ ).

b) Protective equipment

Protective equipment should be worn during operations creating eye hazards. A welding hood should be worn when welding or burning. Use gloves and other protective equipment when required.

c) Other

Principles of good personal hygiene should be followed prior to changing into street clothing or eating. Food should not be consumed in the working environment.

### C.2.2 Emergency medical procedures:

a) Inhalation

Remove to fresh air; get medical attention.

b) Skin

Wash areas well with soap and water.

c) Eyes

Flush well with running water to remove particulate; get medical attention.

d) Ingestion

In the unlikely event that quantities of rope or any of its components are ingested, get medical attention.

### C.2.3 Safety information – fire or explosion hazard

In the solid state, steel components of the rope present no fire or explosion hazard. The organic elements present, i.e. lubricants, natural and synthetic fibres and other natural or synthetic filling and covering materials are capable of supporting fire.

### C.2.4 Disposal:

Dispose of in accordance with local Regulations.

**Annex ZA**  
(informative)

**Relationship between this European Standard and the Essential Requirements of EU Directive 98/37/EC and 95/16/EC**

This European Standard has been prepared under a mandate given to CEN by the European Commission and the European Free Trade Association to provide one means of conforming to Essential Requirements of the New Approach Directives Machinery 98/37/EC, amended by 98/79/EC and Lift 95/16/EC.

Once this standard is cited in the Official Journal of the European Communities under that Directive and has been implemented as a national standard in at least one Member State, compliance with the normative clauses of this standard confers, within the limits of the scope of this standard, a presumption of conformity with the relevant Essential Requirements of that Directive and associated EFTA regulations.

**WARNING:** Other requirements and other EU Directives may be applicable to the product(s) falling within the scope of this standard.

## Bibliography

- [1] ISO 4309, *Cranes – Wire ropes – Care, maintenance, installation, examination and discard.*
- [2] ISO 4344, *Steel wire ropes for lifts – Minimum requirements.*
- [3] prEN 12927-7, *Safety requirements for passenger transportation by rope - Ropes - Part 7: Calculation, repair and maintenance.*
- [4] EN 13414-2, *Steel wire rope slings – Safety – Part 2: Specification for information for use and maintenance to be provided by the manufacturer.*





---

## BSI — British Standards Institution

BSI is the independent national body responsible for preparing British Standards. It presents the UK view on standards in Europe and at the international level. It is incorporated by Royal Charter.

### Revisions

British Standards are updated by amendment or revision. Users of British Standards should make sure that they possess the latest amendments or editions.

It is the constant aim of BSI to improve the quality of our products and services. We would be grateful if anyone finding an inaccuracy or ambiguity while using this British Standard would inform the Secretary of the technical committee responsible, the identity of which can be found on the inside front cover. Tel: +44 (0)20 8996 9000. Fax: +44 (0)20 8996 7400.

BSI offers members an individual updating service called PLUS which ensures that subscribers automatically receive the latest editions of standards.

### Buying standards

Orders for all BSI, international and foreign standards publications should be addressed to Customer Services. Tel: +44 (0)20 8996 9001. Fax: +44 (0)20 8996 7001. Email: [orders@bsi-global.com](mailto:orders@bsi-global.com). Standards are also available from the BSI website at <http://www.bsi-global.com>.

In response to orders for international standards, it is BSI policy to supply the BSI implementation of those that have been published as British Standards, unless otherwise requested.

### Information on standards

BSI provides a wide range of information on national, European and international standards through its Library and its Technical Help to Exporters Service. Various BSI electronic information services are also available which give details on all its products and services. Contact the Information Centre. Tel: +44 (0)20 8996 7111. Fax: +44 (0)20 8996 7048. Email: [info@bsi-global.com](mailto:info@bsi-global.com).

Subscribing members of BSI are kept up to date with standards developments and receive substantial discounts on the purchase price of standards. For details of these and other benefits contact Membership Administration. Tel: +44 (0)20 8996 7002. Fax: +44 (0)20 8996 7001. Email: [membership@bsi-global.com](mailto:membership@bsi-global.com).

Information regarding online access to British Standards via British Standards Online can be found at <http://www.bsi-global.com/bsonline>.

Further information about BSI is available on the BSI website at <http://www.bsi-global.com>.

### Copyright

Copyright subsists in all BSI publications. BSI also holds the copyright, in the UK, of the publications of the international standardization bodies. Except as permitted under the Copyright, Designs and Patents Act 1988 no extract may be reproduced, stored in a retrieval system or transmitted in any form or by any means – electronic, photocopying, recording or otherwise – without prior written permission from BSI.

This does not preclude the free use, in the course of implementing the standard, of necessary details such as symbols, and size, type or grade designations. If these details are to be used for any other purpose than implementation then the prior written permission of BSI must be obtained.

Details and advice can be obtained from the Copyright & Licensing Manager. Tel: +44 (0)20 8996 7070. Fax: +44 (0)20 8996 7553. Email: [copyright@bsi-global.com](mailto:copyright@bsi-global.com).