

BS 7121-13:2009



BSI British Standards

Code of practice for safe use of cranes –

Part 13: Hydraulic gantry lifting systems

NO COPYING WITHOUT BSI PERMISSION EXCEPT AS PERMITTED BY COPYRIGHT LAW

raising standards worldwide™

BSI
British Standards

Publishing and copyright information

The BSI copyright notice displayed in this document indicates when the document was last issued.

© BSI 2009

ISBN 978 0 580 68410 4

ICS 53.020.20

The following BSI references relate to the work on this standard:

Committee reference MHE/3/11

Draft for comment 02/710845 DC

Publication history

First published August 2009

Amendments issued since publication

Date	Text affected
-------------	----------------------

Contents

Foreword *iii*

1	Scope	1
2	Normative references	1
3	Terms and definitions	1
4	Management of installation and the lifting operations	4
5	Contract lift or HGLS hire	9
6	Planning of the lifting operation	11
7	Selection and duties of personnel	13
8	Minimum attributes of personnel	15
9	Training and qualifications	16
10	Selection of HGLS and equipment	18
11	Safety	18
12	Siting of the HGLS	21
13	Erection and dismantling	24
14	Procedures and precautions	30
15	Operating conditions	33
16	Slings and handling of loads	39
17	Thorough examination including testing	42

Annexes

Annex A (normative) Training of appointed persons and HGLS lift supervisors 45

Annex B (normative) Training of HGLS operators and HGLS slingers/signallers 52

Annex C (informative) Background to the BS 7121 series 60

Bibliography 61

List of figures

Figure 1 – HGLS contract options 10

Figure 2 – Basic jacking system 25

Figure 3 – Track beams 26

Figure 4 – Jacking unit details 27

Figure 5 – Jacking unit on track showing track wheel guide locations 28

Figure 6 – Header and cross beams 29

Figure 7 – Typical lift link 30

Figure 8 – Propel cylinder attachment 37

List of tables

Table 1 – Mass of materials 40

Table A.1 – HGLS categories 47

Summary of pages

This document comprises a front cover, an inside front cover, pages i to iv, pages 1 to 62, an inside back cover and a back cover.

Foreword

Publishing information

This part of BS 7121 is published by BSI and came into effect on 31 August 2009. It was prepared by Subcommittee MHE/3/11, *Crane safety and testing*, under the authority of Technical Committee MHE/3, *Cranes and derricks*. A list of organizations represented on this committee can be obtained on request to its secretary.

Relationship with other publications

The Lifting Operations and Lifting Equipment Regulations (LOLER) [1] and the Provision and Use of Work Equipment Regulations (PUWER) [2] came into force in December 1998. Details of the Regulations, an Approved Code of Practice plus Health and Safety Executive (HSE) guidance can be found in the HSE books *Safe use of lifting equipment* [3] and *Safe use of work equipment* [4].

BS 7121-1 provides general recommendations for crane types not covered in an additional part of BS 7121. BS 7121-2 covers in-service inspection, thorough examination and, where appropriate, testing for the safe use of all types of cranes. Subsequent parts of BS 7121 deal with the specific crane types as follows:

- Part 3: Mobile cranes;
- Part 4: Lorry loaders;
- Part 5: Tower cranes;
- Part 6: Derrick cranes;
- Part 7: Overhead/under-hung travelling and goliath cranes;
- Part 8: High pedestal and portal jib dockside cranes;
- Part 9: Container handling cranes;
- Part 10: Rail mounted cranes;
- Part 11: Offshore cranes;
- Part 12: Recovery vehicles and equipment;
- Part 13: Hydraulic gantry lifting systems;
- Part 14: Side boom pipelayers.

When all parts of BS 7121 have been published, CP 3010 will be withdrawn and BS 5744 will be revised to cover manually operated and light cranes only.

Information on the background to the development and use of the BS 7121 series since the initial publication of BS 7121-1 in 1989 is given in Annex C.

The BS 7121 series has been accepted as representing the consensus of practical experience for safety on cranes.

Information about this document

This document is intended to be used in conjunction with other parts of BS 7121 to ensure, so far as is reasonably practicable, that lifting operations are carried out safely.

The Health and Safety Executive (HSE) commends the use of this British Standard to those who have duties under the Health and Safety at Work etc. Act 1974 [5]. This standard was drawn up with the participation of HSE representatives and will be referred to in relevant HSE publications.

Use of this document

As a code of practice, this British Standard takes the form of guidance and recommendations. It should not be quoted as if it were a specification, and particular care should be taken to ensure that claims of compliance are not misleading.

Any user claiming compliance with this British Standard is expected to be able to justify any course of action that deviates from its recommendations.

It has been assumed in the preparation of this British Standard that the execution of its provisions will be entrusted to appropriately qualified and experienced people, for whose use it has been produced.

Presentational conventions

The provisions in this standard are presented in roman (i.e. upright) type. Its recommendations are expressed in sentences in which the principal auxiliary verb is "should".

Commentary, explanation and general informative material is presented in smaller italic type, and does not constitute a normative element.

Contractual and legal considerations

This publication does not purport to include all the necessary provisions of a contract. Users are responsible for its correct application.

Compliance with a British Standard cannot confer immunity from legal obligations.

1 Scope

This part of BS 7121 gives recommendations for the safe use of hydraulic gantry lifting systems (HGLS). Subjects covered include safe systems of work, management, planning, selection, erection and dismantling, inspection, testing, examination, training, operation and maintenance.

NOTE 1 This part of BS 7121 has been developed along the lines of BS 7121-1 with significant modifications to incorporate HGLS-specific aspects. The modifications include some information contained in the US Specialized Carriers and Rigging Association (SC&RA) document, Recommended Practices for Hydraulic Jacking Systems [6].

This part of BS 7121 is intended to be used in conjunction with BS 7121-2, which provides general guidance on the inspection, testing and examination of all types of cranes.

NOTE 2 Annex A and Annex B give detailed recommendations on the training of HGLS personnel. Annex C provides background information on the BS 7121 series.

2 Normative references

The following referenced documents are indispensable for the application of this document. For dated references, only the edition cited applies. For undated references, the latest edition of the referenced document (including any amendments) applies.

BS 7121 (all parts), *Code of practice for safe use of cranes*

3 Terms and definitions

For the purposes of this part of BS 7121, the following terms and definitions apply.

3.1 appointed person

person nominated (typically by the employing organization) to plan, and to have overall control of, the lifting operations

3.2 competent person

person who has such practical and theoretical knowledge and experience of the HGLS and the equipment used in the lifting operation as is necessary to carry out the function to which the term relates in each particular context

3.3 control/power unit

remote station that hydraulically or electronically provides the energy that actuates the cylinders in the jacking units

NOTE On hydraulically powered machines, this unit contains a motor and pump that provides oil flow to the control levers. This flow is then transmitted to the jacking unit via hoses. On electrically powered machines, the control unit sends electrical signals to the jacking unit which contains the motor, pump and oil. On this type of system, only electric cables connect the jacking units to the control units.

3.4 cross beam

second set of header beams (or beam) placed across the first set and used to attach the lifting object

- 3.5 header beam**
structural section, usually a wide flange rolled shape or a fabricated box section
NOTE This beam is placed on the header plates. Lifting accessories can be attached to this beam and the lifting object to facilitate lifting or lowering the lifting object.
- 3.6 header plate**
plate attached to the top of the lift cylinder or lift boom with a swivel fitting, used to attach the header beam to the jacking unit
NOTE This fitting is usually designed such that swivel is possible in one plane only.
- 3.7 HGLS lift supervisor**
person who controls the lifting operation, and ensures that it is carried out in accordance with the appointed person's safe system of work
- 3.8 HGLS operator**
person who operates the HGLS for the purpose of lifting and positioning loads
- 3.9 HGLS slinger/signaller**
person, other than the HGLS operator, who is actively involved in the lifting operation and undertakes tasks such as attaching and detaching the load and directing the HGLS operator to ensure the safe movement of the HGLS
- 3.10 in-service**
condition where the HGLS is handling loads not exceeding the rated capacities with acceptable wind speeds (as stated in the Beaufort Wind Speed Scale) and other conditions as specified by the manufacturer
- 3.11 jacking unit**
structured box supported on wheels having one or more vertical lift cylinders or a vertical lift boom mounted on top
NOTE These units can be free wheeling or self-propelled. The cylinders or booms of these jacking units (usually two or four operated as a set) are extended or retracted to lift or lower the lifting object. The jacking unit can move longitudinally (see 3.18) to transport loads horizontally (see 3.19).
- 3.12 lateral direction**
horizontal direction perpendicular to the axis of the jacking system track
- 3.13 lift boom**
assembly of two or more nested structural boxes that telescopes as the lifting object is lifted or lowered and provides structural strength to resist vertical (and also horizontal) forces that might occur during the lift
NOTE The telescoping of the boom is driven by one or more internal or external hydraulic cylinders. The lift boom can also provide vertical support to the lifted object by means of devices that mechanically lock the sections of the boom to one another. These might be incorporated in a jacking unit.

3.14 lift cylinder

telescopic hydraulic cylinder, either single stage or multiple stage

NOTE Lift cylinders can be single-acting (pressure extend, gravity retract) or double-acting (pressure extend and pressure retract).

3.15 lift link

structural fitting used to provide a point of attachment between the header beam(s) and the lifting accessories attached to the lifting object

NOTE Typically, lift links are made from a piece of flat plate that is cut out to fit around the beam and drilled at the bottom to allow for attachment of a shackle or other pinned fitting. Other designs are also in use, some of which are self propelled.

3.16 lifting accessory

equipment from which the load can be suspended

NOTE Typical lifting accessories include shackles, wire rope slings, synthetic slings, chains, and slings made from wire rope and clips.

3.17 lifting object

component or load lifted (and moved) by an HGLS

3.18 longitudinal direction

horizontal direction parallel to the axis of the jacking system track

NOTE The propel motion of the jacking unit (along a pair of tracks for example) is always in the longitudinal direction.

3.19 propel

longitudinal movement of a jacking system unit along the floor or track

NOTE There are three basic concepts for propel devices:

- a) *built in:* the jacking unit has a motor (usually hydraulically driven) that drives some or all of the wheels of the unit through chains or gears;
- b) *external cylinder:* used on free wheeling jacking units, a cylinder is pinned close to the bottom of the unit's base at one end and to the track at the other. The cylinder is extended and retracted repeatedly to move the jacking units;
- c) *external drive wheels:* one or more motor-driven drive wheels are mounted on the base of the jacking units.

3.20 rated capacity

maximum load that the HGLS is designed to lift with the telescopic cylinder(s) at a specific stage

NOTE The rated capacity was formerly known as "safe working load" (SWL).

3.21 rated capacity indicator**RCI**

device that warns of the approach to overload and prevents the HGLS from being overloaded

NOTE 1 This was previously known as an "automatic safe load indicator (ASLI)" and "overload protection". For information on ASLIs, see BS 7262.

NOTE 2 Further information on RCIs is given in BS EN 12077-2.

3.22 side shifting

lateral movement of a suspended lifting object, usually accomplished by means of hydraulically propelled skates built into the lifting links or rack and pinion travelling device

3.23 track

assembly consisting of two parallel beams, usually tied together at regular intervals, to guide the wheels of the jacking unit

NOTE 1 The beams are either wide flange shapes or fabricated box sections, and are typically fitted with one or more structural elements that guide the jacking unit's wheels. The beam gauge is equal to the transverse wheel spacing of the jacking unit. Most track is designed in short sections that can be bolted together end to end.

NOTE 2 The track members can be designed to carry the jacking unit wheel loads over significant clear spans or to be fully supported by the underlying surface, functioning only to provide a smooth, guided surface for the jacking unit's wheels. Since jacking units are usually operated in pairs, two track assemblies (parallel to one another) are usually required for a lifting operation.

4 Management of installation and the lifting operations

4.1 Safe system of work

A safe system of work should be established and this should be followed for every lifting operation, whether for an individual lift or a group of repetitive operations. The same principles should be applied when the lifting operations are carried out at a temporary site or when the HGLS is being used in a permanent fixture for a length of time.

The safe system of work should include:

- a) planning of the operation (by way of the method statement; see 6.3);
- b) selection, provision and use of a suitable HGLS configuration and associated equipment (may be included in risk assessment; see 6.2);
- c) any necessary preparation of the site and erection and dismantling of the HGLS;
- d) maintenance, examination and, where necessary, testing of the HGLS and equipment;
- e) the provision of properly trained and competent personnel who have been made aware of their relevant responsibilities under the Health and Safety at Work etc. Act 1974 [5], the Management of Health and Safety at Work Act 1992 [7] (which is specific to risk assessments and method statements) and Regulation 9 of PUWER [2];
- f) adequate supervision by properly trained and competent personnel having the necessary authority given by the operator company;
- g) ensuring that all necessary reports of thorough examination and other documents are available;
- h) preventing unauthorized movement or use at all times;
- i) ensuring the safety of persons not involved in the lifting operation.

The safe system of work should be communicated to all parties concerned with the lifting operation.

It is essential for the safety of the operation to ensure that all personnel can communicate clearly in the same language.

NOTE Attention is drawn to PUWER [2] Regulation 4 and 20 on "Suitability of work equipment" and "Stability" respectively and LOLER [1] Regulation 4 on "Strength and stability" in relation to the safe system of work.

4.2 Control of the lifting operation

4.2.1 General

In order to implement the safe system of work effectively, one person should be appointed to have overall control of the lifting operation to act on behalf of the management of the employing organization. The appointment of the person does not remove any legal responsibility from the management but enables them to use the appointed person's expertise, the better to fulfil their responsibilities. The person appointed may have other duties and need not be an employee of the employing organization. The appointed person should have adequate training and experience to enable these duties to be carried out competently.

NOTE The appointed person is appointed by either the employing organization or by the HGLS company, depending on the contractual circumstances. Occasionally, for the duration of the actual lifting operation, the role of the appointed person may be delegated to the HGLS lift supervisor if this is considered to be more appropriate.

4.2.2 Selection and assessment of appointed person

NOTE To assist in the selection of an appointed person, some examples of lifting operations that require different levels of expertise, training and experience, and that impose different duties on the appointed person, are given in 4.3. Recommendations for installation operations are given in Clause 12 and Clause 13.

When selecting an appointed person, the employing organization should take into account the variety and complexity of the operation, as well as all the problems that could arise from proximity hazards and environmental courses. The appointed person should be notified formally in writing of their appointment. The appointed person should be given authority to carry out the duties involved, including consulting others with specialist knowledge and experience, and should be able to delegate duties and tasks for any part of the safe system of work to suitably qualified individuals.

The employing organization should review and assess the performance of the appointed person periodically. The complexity of the installation/lifting operations might entail selection of a more experienced appointed person, as appropriate, or provision of additional training to the existing appointed person.

4.2.3 Avoidance of collisions

On sites where there is a risk of collision between the HGLS and other equipment, the appointed person should plan the sequence of HGLS movements to prevent collisions. Any corresponding instructions from the appointed person to the HGLS lift supervisor should be given directly or via the respective signallers. In such circumstances, the signallers should obtain the agreement of the appointed person before carrying out any operation.

The positioning of the HGLS and components in the out-of-service condition, as specified by the manufacturer's instructions, should be such that no collisions can take place. This activity should be part of the initial planning process.

4.3 Duties of the person appointed to control the lifting operation

4.3.1 General

The appointed person's duties should include the following:

- a) assessing the lifting operation to provide such planning, selection of HGLS, its configuration and lifting accessories, instruction and supervision (by personnel with the necessary competence, experience and qualifications) as is necessary for the task to be undertaken safely. This might include consultation with other responsible bodies, if necessary, and ensuring that, where different organizations are involved, they collaborate as necessary;
- b) ensuring that adequate inspection/examination and maintenance of the HGLS and associated lifting accessories has been carried out;
NOTE 1 For further information, see BS 7121-2.
- c) ensuring that there is an effective procedure for reporting defects and incidents and taking any necessary corrective action;
- d) taking responsibility for the organization and control of the lifting operation.

The appointed person should be given the necessary authority for the performance of all these duties and, in particular, the authority to stop the operation whenever they consider that danger is likely to arise if the operation were to continue.

Duties may be delegated to another person (perhaps the HGLS lift supervisor) where considered appropriate.

NOTE 2 See 4.2.1 regarding delegation of the role of the appointed person to the HGLS lift supervisor during the actual lift if considered to be more appropriate.

The duties of appointed persons for HGLS operations can vary according to the complexity of the operation. The duties for a basic lift are considerably fewer and less demanding than for a lift at a hazardous location. An appointed person employed for a basic lift might not be suitably trained or experienced for a more complicated operation, and another appointment could be required for this. The information given in 4.3.2 to 4.3.4 can be used so that an appropriate appointment is made and a suitable method statement produced for each lifting operation. The requirement for an appointed person with appropriate training and experience also applies to installation operations.

4.3.2 Basic lift

If the mass of the load(s) can be simply established, the lift is a static lift (straight up and down lift; see 15.2.2) and there are no significant hazards or obstructions within the area of the operation, then the duties of the appointed person should include the following:

- a) establishing the mass of the load. This can be by a reliable source of information, weighing the load, or calculation (with allowance for possible inaccuracies);

NOTE If HGLSs are used to lift loads from water, the load could also include forces due to water flow or suction and the effect of loss of buoyancy.

- b) selecting the HGLS, based on the mass of the load, including the hook block and any lifting tackle, and the maximum height of lift. The rated capacity of the HGLS should be specified by the manufacturer in the information for use supplied with the HGLS, or else on the current report of thorough examination issued by the competent person. The manufacturer's sales leaflets should not be relied on for the rated capacity for a specific HGLS;
- c) considering the location of the operation, taking into account the access and egress required for the HGLS, and the suitability of the ground to take the loads imposed on the HGLS during preparation for the lift and during the lift itself;
- d) ensuring that the HGLS is not operated in wind speeds in excess of those given in the instruction manual for the HGLS. Consideration should also be given to the wind area of the load to ensure that its movement in the wind does not present a hazard;
- e) ensuring that the HGLS has been thoroughly examined at least within the previous 12 months (including testing, where appropriate), inspected and checked before use;
- f) ensuring that a system for reporting defects is in place;
- g) selecting appropriate lifting accessories, including their method of attachment to the load, and any protection used to prevent damage;
- h) ensuring that lifting accessories have been thoroughly examined, at least within the previous six months, inspected and checked before use;
- i) designating a person to check the lifting accessories and any lifting points that are provided on the load to ensure they are free from any obvious defects before attaching the load to the HGLS;
- j) briefing all persons involved in the lifting operation to ensure that the safe system of work described in the method statement is understood. All persons involved in the lifting operation should be instructed to seek advice from the appointed person if any change is required to the lifting operation, or if any doubts about safety arise. If handlines/taglines are required to give more control of the load, the appointed person should designate persons to handle the lines;
- k) checking that no changes are required in the safe system of work if numerous loads are to be lifted over a long period;
- l) ensuring that there is an HGLS lift supervisor designated to direct personnel and that the operation is carried out in accordance with the method statement.

The appointed person and HGLS lift supervisor should be aware of the limits of their knowledge and experience concerning lifting operations, and, when conditions exceed these limits, further advice should be sought.

4.3.3 Standard lift

If there are significant hazards, either within the working area of the HGLS or on the access route to the working area, or the lifting operation includes longitudinal travel (see 15.2.3), the duties of the appointed person should include the following, in addition to the duties listed in 4.3.2:

- a) investigating all hazards in the operating area, including any areas required for access or erection/dismantling of the HGLS;

NOTE 1 Hazards can be from surrounding buildings, or overground or underground services.

- b) taking account of increased risks if the load is lifted from a structure at a height above the standing position of the HGLS;

NOTE 2 Additional risks can arise from the HGLS lift supervisor not being able to observe the load while taking the initial strain, and movements due to deflections as the load is lifted clear of the supporting structure making it not possible to put the load back down.

- c) liaising with any other person or authority, as required to overcome any hazard, by including any necessary corrective action or special measures in the safe system of work;
- d) considering the effect of the lifting operation on surrounding property or persons, including the general public. This should lead to arranging for appropriate action to minimize any adverse effects, and to giving appropriate notice to all persons concerned.

4.3.4 Complex lift

If the lifting operation includes topping and tailing, side shifting or the use of more than four jacking units (see 15.2.4 and 15.2.5), is at a location with exceptional hazards (for example, at a chemical plant), or involves lifting a load from height, or if the load being lifted is a complex shape or with a large wind area, the appointed person should ensure, in addition to the duties listed in 4.3.2 and 4.3.3, that:

- a) the mass of the load and the position of its centre of gravity are accurately known;
- b) the wind area of the load is known and a limiting wind speed for lifting is established;
- c) any lifting points provided on the load are adequate for the loads applied;
- d) the method statement includes access, ground conditions, erection etc., as well as the exact sequence of operations when lifting the load.

NOTE The lifting of persons with an HGLS is regarded as a complex lift. Further guidance is given in BS 7121-1.

4.4 Duties and responsibilities of other persons

As described in 4.3, the appointed person needs to plan HGLS lifting operations on the basis that personnel with the necessary competence, experience and qualifications are available.

An adequate number of personnel should be used as considered necessary to complete a safe HGLS lifting operation. This always involves an HGLS lift supervisor, assisted by an HGLS operator/s and one or more HGLS slingers/signallers. The number of personnel should be selected so that all of the jacking units and associated equipment can be satisfactorily observed throughout the operation. Every effort should be made to ensure that no personnel are positioned within the lifting area during the lifting operation.

NOTE Attention is drawn to LOLER [1] Regulation 8(1)(c), which requires that lifting operations are carried out in a safe manner.

5 Contract lift or HGLS hire

5.1 General

Given the wide variety of contractual arrangements, it is important to ensure that the planning, organization control and management of lifting operations is not compromised. In general, any organization requiring a load to be moved by an HGLS, which does not have its own lifting equipment, has two basic options: hiring an HGLS (hired HGLS) or employing a contractor to carry out the lifting operation (contract lift). The difference between the two options is summarized in Figure 1.

If an individual or organization does not have expertise in lifting operations they should not hire an HGLS but should opt for a contract lift. Before entering into a contract, the employing organization should satisfy itself that the contractor has the necessary competence to carry out the work.

NOTE Responsibilities for insurance in terms of the HGLS, personnel, the load and third parties might also need to be clarified.

5.2 Contract lifting operations

The employing organization may enter into a contract with a contractor who undertakes the work on their behalf.

The parties to the contract should ensure that:

- a) all work is carried out in accordance with the BS 7121 series;
- b) the contractor appoints a person, in accordance with 4.3, to the satisfaction of the employing organization;
- c) all information or services provided by the employing organization to facilitate compliance with the BS 7121 series are notified to the contractor in writing.

The contractor should carry out lifting operations in accordance with the BS 7121 series. The contractor should be given full authority by the employing organization to work in accordance with the BS 7121 series including, where appropriate, authority to control and instruct the employing organization's personnel.

NOTE Although the BS 7121 series is intended to assist organizations to comply with their statutory and common law obligations, it does not relieve them from these obligations.

Before entering into a contract, the employing organization should ensure that the contractor has the necessary competence to carry out the work in accordance with the BS 7121 series.

Figure 1 HGLS contract options

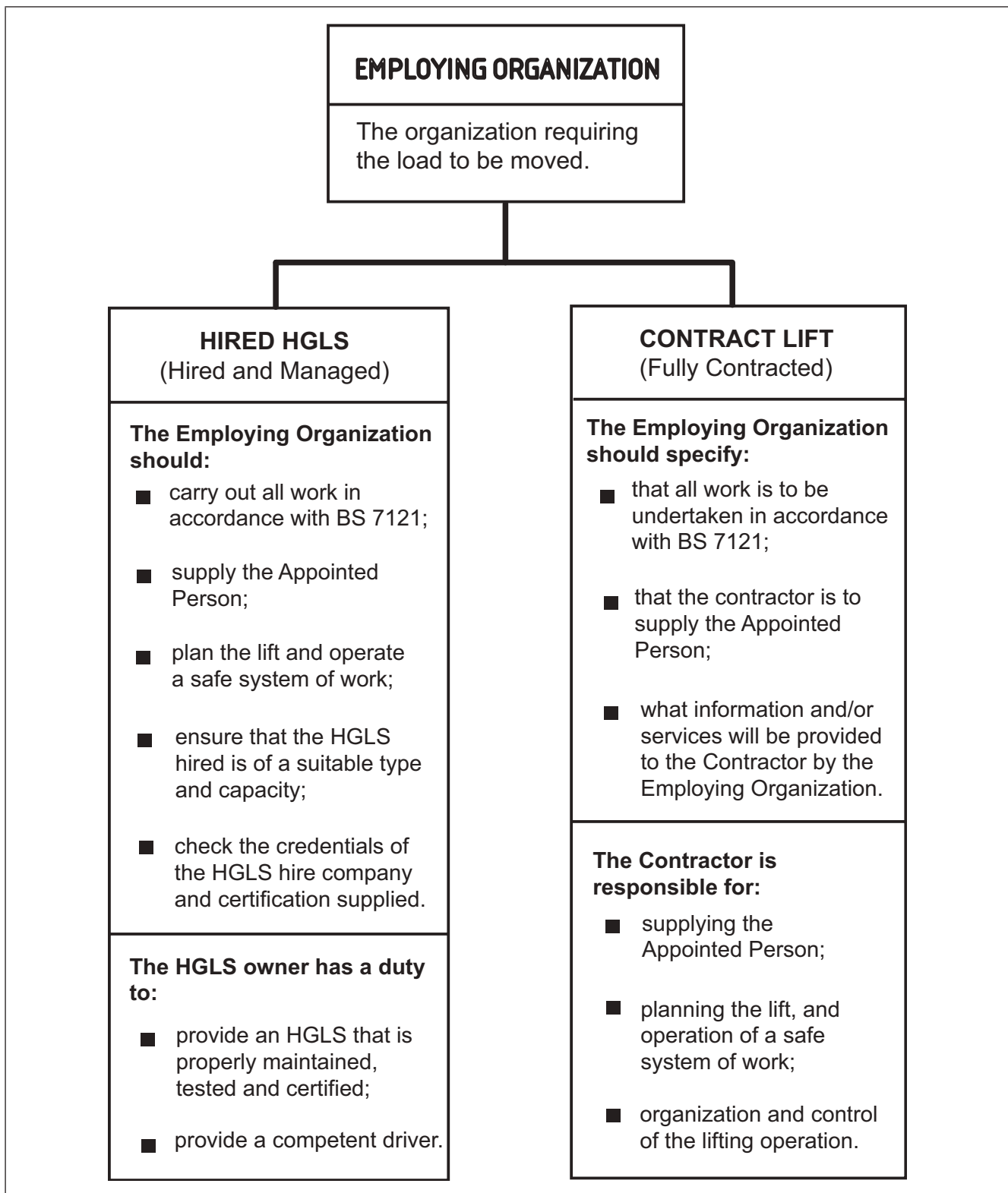

5.3 User's duties when using a hired HGLS

When an HGLS is hired out from a third party, together with an HGLS operator, to the user organization, the HGLS owner should provide a competent HGLS operator (see 7.2.2 and 8.2) and an HGLS that is properly maintained, inspected, thoroughly examined, tested

in accordance with BS 7121-2 and has a current report of thorough examination (see 11.7, 11.8, 14.2, 14.3, 14.5 and Clause 17).

The user organization retains the responsibility for nominating the appointed person in accordance with 4.2 and for following the recommendations given in the BS 7121 series. Notwithstanding any advice the HGLS owner might have offered concerning the selection of a particular HGLS or any other relevant matter, the responsibility for ensuring that the HGLS is of a suitable type, size and capacity for the task being undertaken, and for planning the operation, remains with the user organization. The appointed person should be fully involved in the planning process in conjunction with the HGLS owner.

Therefore, if an individual or organization does not have expertise in lifting operations, they should not hire an HGLS but should opt for a contract lift.

6 Planning of the lifting operation

6.1 General

All lifting operations should be planned to ensure that they are carried out safely and that all foreseeable risks have been taken into account. Planning should be carried out by an appointed person who has the appropriate knowledge for the lift being undertaken (see 4.3.2 to 4.3.4).

In cases of repetitive or routine basic lifting operations, this planning might only be necessary in the first instance, with periodic reviews to ensure that no factors have changed.

Planning of the lifting operation should take into account:

- a) the load, its characteristics and the method of lifting;
NOTE It might also be necessary to make allowance for any adhesion between the load and its support.
- b) the selection of a suitable HGLS configuration appropriate to the operation ensuring that adequate clearances are maintained between the load(s) and the HGLS structure;
- c) the selection of accessories for lifting/lifting attachments, the mass to be taken into account when assessing the load on the HGLS;
- d) the position of the HGLS and of the load before, during and after operation;
- e) the site of the operation, including proximity hazards, space availability and suitability of the grounds or foundations;
- f) the way in which the lift is to be performed, particularly in terms of the location of the running tracks (where appropriate);
- g) the access route to where the lift is to be carried out in terms of transporting and erecting the HGLS equipment;
- h) power supply details (if required);
- i) any necessary erection and dismantling of the HGLS;
- j) the environmental conditions (lighting, heating, weather – including wind – conditions) that exist or could occur at the site of the operation, which could necessitate stopping the operation when conditions are unsuitable.

Although information and records provided by the employing organization on aspects relating to items c) and h) should be considered, the information should always be confirmed by a competent person when this is deemed necessary. As a general rule, a competent person (e.g. structural engineer) should always be consulted if there is any doubt whatsoever about the structural integrity of the floor.

If possible, the mass of the lifting object and the position of the centre of gravity should also be checked on the day of the lifting operation. The requirement for these checks to be undertaken should be included in the method statement, as should the requirement to recheck the floor conditions if this is considered to be necessary (in case of heavy rain on an outside site, for example).

If the required capacity (load) of an HGLS is not available for a given lift, then it is usually acceptable for a higher capacity (load) system to be used. However, in considering this, a re-assessment of the floor loadings should be carried out to allow for heavier equipment.

An HGLS lift supervisor and HGLS operator with the required training and experience should be selected. It is not acceptable for a person to be substituted (due to illness or other reasons) by a person unless he/she has the equivalent training and experience. To this end, it is important for operator companies to maintain good training of their personnel by ensuring that they have constant exposure to new experiences and job types (see Clause 9).

6.2 Risk assessment

The risk assessment carried out by the appointed person as part of the planning process should identify the significant hazards associated with the proposed lifting operation. The assessment should evaluate the risks involved, and the nature and extent of any measures required to mitigate those risks. The appointed person should take into consideration hazards identified by the overall site risk assessments.

NOTE The HSE has produced guidance in a leaflet entitled *Five steps to risk assessment – A step by step guide to a safer and healthier workplace [8]*.

Generic risk assessments are unlikely to be sufficient since most sites have hazards that are unique to that situation and should be taken into account in the separate site-specific assessment.

The results of the risk assessment should be recorded in writing and used in the preparation of the method statement (see 6.3) for that site.

The risk assessment, together with the manufacturer's instructions, should then be used to develop a detailed method statement for the safe transportation, assembly, erection, use and dismantling of the equipment at that site.

6.3 Method statement

Once the risk assessment has been carried out, the appointed person should ensure that a full method statement is prepared, detailing the safe system of work (see 4.1) for the lifting operation and including the risk assessment.

The appointed person should, when necessary, consult with others with specialized knowledge and experience to assist in the planning process for which the appointed person retains responsibility.

A copy of the method statement and associated operating instructions should be given to all those involved in the planning of the lifting operation, including the employing organization and the owner of the HGLS. The method statement may be based on an existing template or written specifically for the job. The HGLS operator should adhere to the method statement.

The method statement might include engineering documents prepared for all aspects of the job. These plans might include one or more of the following:

- a) drawings or sketches of the lifting equipment;
- b) layout views of the HGLS at the lift site;
- c) specifications for all equipment;
- d) other pertinent information, e.g. site topography (site levels).

If unforeseen situations arise which necessitate deviations from the method statement to be made, the HGLS lift supervisor should formally assess the method statement and, accordingly, refer back any changes to the appointed person. Such changes should always be recorded in a written form by the appointed person.

7 Selection and duties of personnel

NOTE See 4.2 and 4.3 for the selection and duties of the appointed person.

7.1 Selection of personnel

Safe HGLS lifting operations (including installation) depend upon the selection of suitable personnel who are competent to carry out the required duties. Records of training and experience of persons such as the HGLS lift supervisor and HGLS operator assist in the selection of personnel for particular applications (including when substitution might be required). HGLS lift supervisors, HGLS operators and HGLS slingers/signallers should be trained in accordance with Annex A and Annex B, as appropriate.

Those responsible for the selection of personnel should ensure that the personnel involved in the operation are efficiently organized in order to ensure good teamwork in the working situation.

Work associated with lifting operations should not be carried out by personnel whose efficiency is impaired by alcohol, drugs or other influences. All personnel in the team should be made aware of both this fact and their other duties (see 7.2).

Where personnel are undergoing training, they should be supervised by appropriate personnel.

NOTE For basic lifts, it might be appropriate for one person to undertake more than one of the duties identified in 7.2, depending on the hazards identified by the risk assessment.

7.2 Duties of personnel

7.2.1 HGLS lift supervisor

The HGLS lift supervisor should be responsible for:

- a) directing the on-site erection and dismantling of the HGLS assembly;
- b) supervising the moving of the lifting object;
- c) supervising the correct operation of the HGLS in accordance with the manufacturer's instructions and within the safe system of work (see 4.1) as detailed in the method statement;
- d) in the absence of the appointed person, briefing the lifting team members on the safe system of work;
- e) consulting with the appointed person in the event of any deviation from the safe system of work.

The HGLS lift supervisor should ensure that all necessary guidance and help is provided from other personnel (i.e. the HGLS slingers/signallers) nominated by the appointed person on behalf of the employing organization.

7.2.2 HGLS operator

The HGLS operator should be responsible for:

- a) moving the lifting object under the guidance of the HGLS lift supervisor;
- b) the correct operation of the HGLS in accordance with the manufacturer's instructions and within the safe system of work (see 4.1) as detailed in the method statement.

7.2.3 HGLS slingers/signallers

HGLS slingers/signallers and their appointment are the responsibility of the appointed person or employing organization. The HGLS slingers/signallers should be positioned around the HGLS unit to monitor and give feedback during the operation so as to ensure that the lift is carried out satisfactorily and in a safe manner. Typical duties that these HGLS slingers/signallers might be asked to perform include:

- a) erecting and dismantling the HGLS assembly in accordance with the manufacturer's instructions (see Clause 13);
- b) attaching and detaching the lifting object to and from the HGLS;
- c) monitoring certain aspects of the lifting operation and providing appropriate information to the HGLS lift supervisor by way of signalling, the use of radio control, television monitoring or other appropriate methods.

An HGLS slinger/signaller might be required to be positioned so as to be able to observe at least one jacking unit and associated equipment and be visible to the HGLS operator (see 4.4 on positioning of personnel outside the lifting area). All slings and attachments should be observed at all times during a lifting operation by one or more HGLS slingers/signallers (and/or by the HGLS operator). Viewing aids, such as closed-circuit

television (CCTV), laser monitoring or binoculars, should be used for this purpose whenever they are considered necessary.

7.2.4 Maintenance personnel

Maintenance personnel should be responsible for maintaining the HGLS and associated equipment and ensuring its safe and satisfactory operation. They should carry out all necessary maintenance in accordance with the manufacturer's maintenance manual and within the safe system of work (see 4.1). Wherever necessary, the manufacturer's maintenance manual may be supplemented by the operator company to suit their particular needs and requirements. Such information should be passed on to the manufacturer.

8 Minimum attributes of personnel

8.1 HGLS lift supervisor

The HGLS lift supervisor should be:

- a) competent to perform the tasks required of them (including the ability to judge distances, heights and clearances);
- b) fit, with particular regard to eyesight, hearing and reflexes;
- c) physically able to supervise the HGLS safely;
- d) adequately trained (see 9.2 and Annex A) for the type of HGLS being operated, with sufficient knowledge of the HGLS and its safety devices;
- e) fully conversant with the duties of the HGLS operator and HGLS slingers/signallers (see 7.2.2 and 7.2.3) and should understand signal coding (as defined in BS 7121-1) and any alternative methods of relaying relevant information;
- f) authorized by the employing organization to supervise the HGLS.

8.2 HGLS operator

The HGLS operator should be:

- a) competent to perform the tasks required of them (including the ability to judge distances, heights and clearances);
- b) fit, with particular regard to eyesight, hearing and reflexes;
- c) physically able to operate the HGLS safely;
- d) adequately trained (see 9.3 and Annex B) for the type of HGLS being operated, with sufficient knowledge of the HGLS and its safety devices;
- e) fully conversant with the duties of the HGLS slingers/signallers (see 7.2.3) and should understand signal coding (as defined in BS 7121-1) and any alternative methods of relaying relevant information;
- f) authorized by the employing organization to operate the HGLS.

8.3 HGLS slingers/signallers

The HGLS slingers/signallers should be:

- a) competent (including the ability to judge distances, heights and clearances);
- b) fit, with particular regard to eyesight, hearing, reflexes and agility;
- c) physically able to handle lifting accessories (where appropriate);
- d) trained in the technique of slinging (where appropriate);
- e) trained in the technique of signalling and should understand signal coding (as defined in BS 7121-1);
- f) capable of giving precise and clear verbal instructions where audio equipment (e.g. radio) is used, and capable of operating the equipment;
- g) capable of giving information to the HGLS lift supervisor and/or HGLS operator to enable the lifting operation to be carried out safely;
- h) nominated to carry out slinging duties (where appropriate);
- i) adequately trained in the erection, dismantling and working of the type of HGLS and associated equipment being utilized (where appropriate).

8.4 Maintenance personnel

The maintenance personnel should be:

- a) competent;
- b) fully conversant with the HGLS and the associated equipment they are required to maintain and its hazards;
- c) properly instructed and trained, including attending appropriate courses given by the supplier of the HGLS (or their agents);
- d) familiar with the procedures and precautions recommended in Clause 14.

9 Training and qualifications

9.1 General

The Supply of Machinery Regulations 2008 [9] require that information is made available by the manufacturer on the operation and servicing of each size or model of HGLS sold to the purchaser. In addition, manuals for each HGLS model, and other instrumental information, schematic drawings, part lists and maintenance requirements, are generally provided to the purchaser. The operating company, after initial post-purchase training by the manufacturer/seller, should assume responsibility for training its personnel in the use of the equipment, and should ensure each specific lift is planned and engineered to allow for training to safely accomplish the designated tasks.

9.2 HGLS lift supervisor

In order to attain the necessary attributes of an HGLS lift supervisor (see 8.1), significant understanding and experience should be gained on both the theoretical and practical aspects of HGLS equipment. An HGLS lift supervisor would normally have a good background in the general engineering or crane industries, have attended appropriate training courses on the relevant HGLS systems and have assisted other HGLS lift supervisors in performing a substantial number of lifting operations. Once the operator company is fully satisfied that the person has attained the required attributes, a company training record should be issued designating him/her to HGLS lift supervisor status. Recommendations for HGLS lift supervisor training and competency assessment are given in Annex A.

9.3 HGLS operator

In order to attain the necessary attributes of an HGLS operator (see 8.2), significant understanding and experience should be gained on both the theoretical and practical aspects of HGLS equipment. An HGLS operator would normally have a good background in the general engineering or crane industries, have attended appropriate training courses on the relevant HGLS systems and have assisted other HGLS operators in performing a substantial number of lifting operations. Once the operator company is fully satisfied that the person has attained the required attributes, a company training record should be issued designating him/her to HGLS operator status. Recommendations for HGLS operator training and competency assessment are given in Annex B.

9.4 HGLS slingers/signallers

It is desirable for HGLS slingers/signallers to have an understanding and experience of the practical aspects of HGLS equipment. It is also desirable for HGLS slingers/signallers to have a general background in the crane industry and to have attended appropriate training courses on the relevant systems. Management discretion should be exercised in designating personnel to be HGLS slingers/signallers for specific lifts. Recommendations for HGLS slinger/signaller training and competency assessment are given in Annex B.

9.5 Maintenance personnel

It is desirable for maintenance personnel to have an understanding and experience of both the theoretical and practical aspects of HGLS equipment. They should ideally have attended relevant operation and servicing training courses for the appropriate systems and equipment. A company training record should be issued once the operator company is satisfied that the person has acquired the necessary attributes relating to maintenance.

10 Selection of HGLS and equipment

Selection of the HGLS and equipment depends to a large extent on those systems available within or to the operator company. However, the following key aspects should be considered during the selection process:

- a) the type of lift to be performed. One or a combination of the following five types of lifts can be performed by an HGLS:
 - 1) straight up and down lift, i.e. raising and lowering the lifting object;
 - 2) straight up and down lift with longitudinal travel, i.e. lifting and moving the lifting object horizontally;
 - 3) top and tail (stand up/lay over) lift;
 - 4) side shifting lift, i.e. moving the lifting object horizontally in lateral direction;
 - 5) combination lift, i.e. using other types of lifting equipment in conjunction with the HGLS, such as fork lift trucks, mini-cranes, mobile cranes or machine skates.
- b) the lifting object to be moved in terms of size, mass, position of centre of gravity and the structural integrity and position of the lifting accessories;
- c) the distance the lifting object needs to be moved in the longitudinal direction (and lateral direction, if appropriate) and the minimum and maximum stroke required by the HGLS jacking units/lift cylinders;
- d) site, ground and environmental conditions, or restrictions arising from adjacent buildings or machinery etc.;
- e) space available (including height) for HGLS access, erection, travelling, operation and dismantling.

NOTE See 6.1 with regard to the substitution of a higher capacity (load) HGLS.

11 Safety

11.1 General

The person or organization having overall control of the place of work, and the employers of personnel involved in the lifting operation, have responsibility for safety. In order that this responsibility can be effectively discharged, the appointed person should be given the necessary authority to ensure that adequate systems to achieve safety are in operation. Safety matters relating to lifting operations include the use, maintenance, repair and renewal of safety equipment and the instruction, and allocation, of responsibilities to the various personnel in relation to the equipment.

11.2 Identification of the HGLS lifting team

The members of the HGLS lifting team should be easily identifiable, e.g. by wearing high visibility clothing if appropriate.

NOTE When choosing high visibility clothing, backgrounds, type of illumination and other relevant factors ought to be considered.

11.3 Personal protective equipment

The appointed person should ensure the following:

- a) personal protective equipment is available that is appropriate for the conditions of the location, such as helmets, safety spectacles, safety boots and ear defenders;
- b) equipment is inspected before and after use and maintained in good working order or replaced, where appropriate;
- c) a record of inspection and repairs is maintained, where appropriate.

Certain safety equipment (e.g. helmets and safety harnesses) can deteriorate with age and should therefore be considered for renewal periodically. Safety equipment damaged by impact should be replaced immediately.

11.4 Use of personal safety equipment

All personnel working on, visiting or in the vicinity of the HGLS should be made aware of the requirements relating to their personal safety and to the use of the personal safety equipment provided.

Personnel should be instructed in the correct use of the safety equipment provided and should be required to use it, as appropriate (see 11.7).

11.5 Access and egress, including emergency escape

11.5.1 General

Safe access to and egress from the HGLS lifting area of work, including means of emergency escape, should be provided and maintained.

11.5.2 Segregation of the HGLS area of work

As identified in the risk assessment, an exclusion zone should be set up around the HGLS operation to ensure that persons not involved in the operation are unable to enter the area. Access to the exclusion zone should be monitored at all times.

Arrangements for monitoring the exclusion zone should be detailed in the method statement.

No person(s) should be permitted to climb on any parts of the HGLS configuration without first obtaining the HGLS lift supervisor's permission.

11.5.3 Instruction of personnel

Personnel should be instructed to use only the proper access and egress routes that have been designated and specified.

11.6 Fire extinguishers

Any fire extinguishers that are selected should be appropriate to the hazards involved in the particular lift area. Such hazards should include extreme possibilities, such as the spraying of hydraulic oil.

11.7 HGLS safety equipment

11.7.1 Rated capacity indicator and limiter (RCI/L)

NOTE The RCI was formerly known as the automatic safe load indicator.

A rated capacity indicator should be fitted on the HGLS to give warning of an approach to the rated capacity and a further warning when an overload occurs. The warnings should be clearly evident to the HGLS operator.

The RCI can take the form of a pressure gauge with suitable markings for both approach and overload.

The RCL can often take the form of a pressure relief valve on an individual jacking unit.

On more complex HGLS with multiple jacking units and/or where HGLS are used in combination with other lifting equipment, where there is a risk of overloading, a supervisory RCI/L should be specified by the appointed person.

11.7.2 Level indicator

Level indicators are able to sense the level position of a lift beam and give a constant read out at the control module, allowing the HGLS operator to make the proper adjustments to the height of the respective lift cylinders. HGLS beam level indicators should be fitted and used in accordance with the instruction manual, and maintained in good working order.

11.7.3 Marking of controls

The HGLS controls should be clearly and legibly marked to indicate function and direction of movement.

11.7.4 Guarding

Where fitted, guarding should be installed and maintained in good condition.

11.8 Documentation

11.8.1 Rated capacity charts

Readily understandable rated capacity charts applicable to the relevant HGLS, and for the different extension stages of the telescopic hydraulic cylinders, should be prominently displayed to the HGLS operator.

11.8.2 Instruction manuals

Instruction manuals in English (and other relevant languages) containing information on the erection, use and dismantling of the HGLS should be readily available for all relevant site personnel at the site on which the HGLS is being operated.

11.8.3 Reports of thorough examination and supplementary test

All current reports of thorough examination and supplementary test for the HGLS and associated lifting accessories should be kept by the operator company and a copy should accompany the equipment.

11.8.4 Records

Records should be maintained for each HGLS model by the HGLS owner that are sufficient to enable the condition of the HGLS to be determined and its fitness for further operation to be properly assessed.

The records should include the following:

- a) technical information, including maintenance instructions and performance data provided by the manufacturer (if available);
- b) test certificates, reports of thorough examinations and records of inspections carried out on the HGLS (whether statutory or not);
- c) records of significant repairs and modifications to the HGLS and associated equipment, including renewal of major parts and confirmation of completion including signatures of responsible person(s).

Following an accident/incident, the HGLS should be thoroughly examined by a competent person.

Except where specific forms are required by legislation, the format in which records are kept is not important. Whatever method is used should be adequate to ensure that the records allow a relevant and coherent history of the HGLS to be readily retrieved. The records should be clearly identifiable with the HGLS and associated equipment to which they refer.

12 Siting of the HGLS

12.1 General

The siting of the HGLS should take account of all the factors that might affect its safe operation, particularly the following:

- a) the load-bearing capacity of the general support for the HGLS;
- b) the presence and proximity of other hazards;
- c) the impact of environmental conditions;
- d) the adequacy of access to allow for the placing or erection of the HGLS in its working position, and for dismantling and removing the HGLS and associated equipment following completion of lifting operations.

12.2 HGLS standing or support conditions

12.2.1 Support condition types

Conditions available for supporting the HGLS vary depending on the specific lift site and type of operation being performed. Such conditions include the following:

- a) soil/stone – the working site surface is soil, crushed stone or the like;
- b) slab on grade of stone – the working surface is a concrete slab on grade stone;
- c) structural floor system – the working site surface is a structural floor system, such as a building floor;
- d) pit and bulkhead locations – the jacking system is set up over, or adjacent to, a pit or bulkhead such that lateral pressures created by the jacking system loads and their effects on the pit walls or bulkhead need to be evaluated;
- e) offshore/water surface – the jacking system is used on a vessel, such as a barge. The vessel can be floating, partially grounded or fully grounded.

12.2.2 Load distribution system types

The following types of load distribution systems can be used for an HGLS, depending on the requirements for specific lift applications:

- a) track – the jacking units are installed on a track system as defined in 3.23. This is by far the most common load distribution type used (see 13.5.1);
- b) plate – the jacking units are installed on flat steel plates. However, under most circumstances, flat plates cannot be depended upon to provide significant distribution of the applied load. Plate normally provides only a smooth hard surface on which the jacking units can be propelled. The possibility of “sinking” should therefore always be considered;
- c) stands – structural frames directly support a jacking unit (propel not possible) or support a track system (propel possible);
- d) mats/timber – mats, cribbing timbers and other wooden elements are used as part of the load distribution system under an HGLS. However, experience has shown that, if lifts have to be undertaken on soft ground using mats, substantial reductions of HGLS capacity should be considered for adequate stability to be ensured. In each case, all wooden elements used for load distribution systems should be in good condition.

12.2.3 Load considerations

The appointed person should ensure that the loads imposed by the HGLS can be sustained by the ground or any means of support, by obtaining the assessment of a competent person or company able to do so.

The loadings should include the combined effects of the following:

- a) the dead mass of the HGLS and associated equipment;
- b) the dead mass of the lifting object and lifting accessories;
- c) dynamic forces caused by movements of the HGLS and/or lifting object;
- d) wind loading, taking into account the degree of exposure of the site.

In-service conditions are likely to produce the greater imposed loading but out-of-service and erection/dismantling conditions should be taken into consideration. As the vertical and horizontal forces are unlikely to be uniformly distributed, an allowance should be made for these and for any other unpredictable effects.

The appointed person should ensure that the ground or any means of support is such that the HGLS can operate within horizontal tolerances and other parameters which might be specified.

12.3 Proximity hazards

12.3.1 Outdoor aspects

For an HGLS operating on an outdoor site, consideration should be given to the presence of proximity hazards, such as overhead electric lines or cables, nearby structures, vehicles or ships being loaded or unloaded, and stacked goods.

The danger to or from underground services, such as gas mains or electric cables, should be taken into account. Precautions should be taken to ensure that the HGLS support is clear of any underground services or, where this is not possible, that the services are adequately protected against damage.

The appointed person should ensure that the local offices of the electricity company or other line operator are consulted if the HGLS is to be used within 9 m of overhead lines on wooden poles or 15 m of overhead lines on steel towers.

WARNING. All overhead lines and other electrical apparatus should be treated as live unless declared "dead" and "safe" by the line operator.

12.3.2 Indoor aspects

For an HGLS operating in an indoor site, consideration should be given to the presence of factory services, such as water and gas supplies, steam lines, compressed air lines, electrical cables, lighting, ventilation ducts, gas heating units and other installations.

13 Erection and dismantling

13.1 Planning

The erection and dismantling of the HGLS should be thoroughly planned and properly supervised in the same way as the lifting operation (see Clause 6). Erection and dismantling should be incorporated in the method statement. This might include assembly drawings of all components showing erection markings, bolts and washers etc.

NOTE The planning has to take account of the need to dismantle the HGLS after use.

A correctly planned erection and dismantling procedure, as referred to in the method statement, should ensure that:

- a) the entire erection and dismantling operation is controlled by the HGLS lift supervisor (see 7.2.1);
- b) all personnel involved have a sound knowledge of their part in the operation;
- c) only correct parts and components are used when replacement is necessary;
- d) the HGLS and associated equipment are level to within specified limits.

13.2 Transportation

Transportation (including on-lorry and off-lorry loading) of the HGLS equipment to and from the site of operation should be carried out in a safe manner so as to ensure that no damage is sustained to the components that could have a detrimental effect on the lifting operation. On-lorry/off-lorry loading should be supervised by a competent person. If any part of the equipment is damaged during off-lorry loading (prior to a lift), the HGLS lift supervisor should authorize the use of a spare or send for a replacement unless he is absolutely satisfied that the damage is of no consequence in terms of impairing the integrity of the component.

13.3 Manufacturer's erection and dismantling instructions

The HGLS manufacturer's instructions (when available) should be closely followed. Any departure from the specifications should be approved by the manufacturer, a competent engineer or the appointed person, to ensure the stability of the HGLS and that structural and mechanical parts are not subject to excessive loading.

13.4 Identification of components and materials

13.4.1 Components

All major components that form part of an HGLS and are dismantled for transportation should carry a clear identification mark.

13.4.2 Materials

Where components have been manufactured from special materials, they should be marked to indicate this.

NOTE Nuts and bolts manufactured from high tensile steel or other special steels carry markings so that they can be distinguished from other nuts and bolts. High strength friction grip bolts ought not to be reused.

13.4.3 Electrical supply

The following points should be noted if the HGLS is electrically operated.

- The HGLS should have a power cable with a ground wire connected to an effective earth connection.
- The HGLS should be internally grounded to the power cable ground in accordance with applicable electric codes and standards.
- The characteristics of the power supply and of the HGLS equipment should be checked for compatibility before connection.
- Any trailing cable should not be damaged during operational movement or when the jacking units are travelling. The travel distance should be well within the length of the trailing cable.

13.5 Erection of components

NOTE Figure 2 gives an example of a basic jacking unit system, showing the arrangement of different components.

Figure 2 Basic jacking system

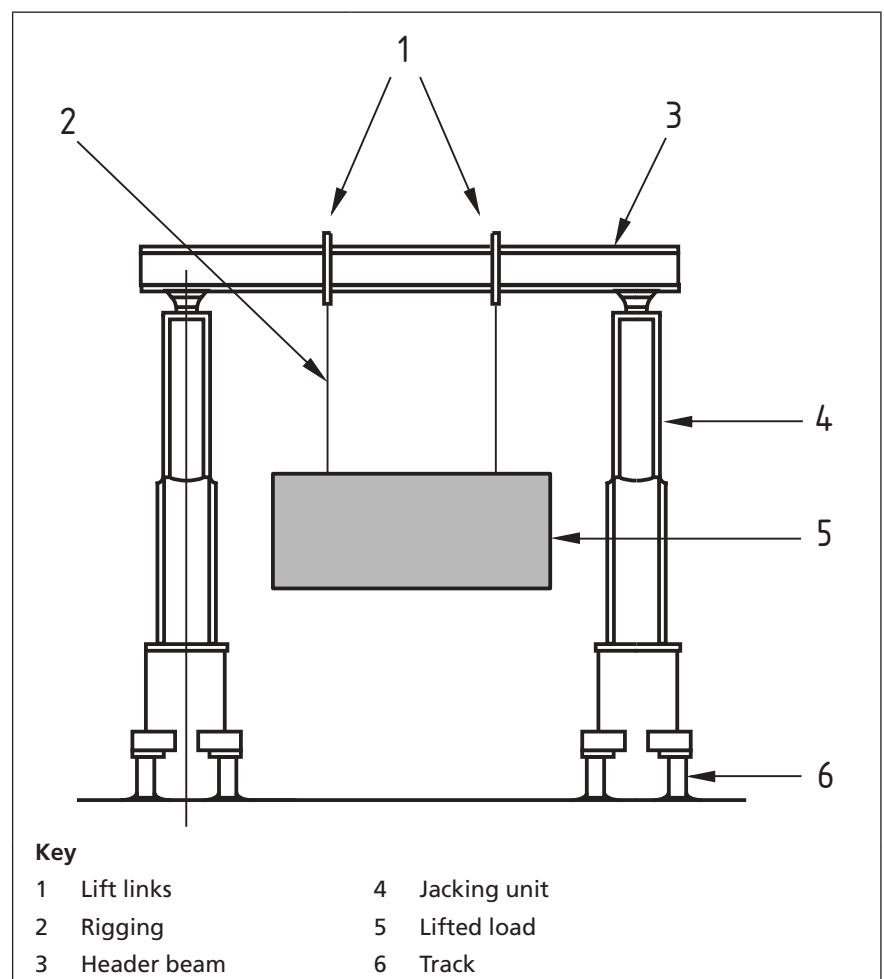

13.5.1 Tracks

Measurements should be made to ensure that the tracks are level, horizontal and parallel to each other within the prescribed tolerances. If there are gaps or the track is not level, steel shim packers should be placed under the track. The HGLS lift supervisor should therefore ensure that the track is laid to be within the tolerances stipulated. Tracks should be supported in a similar manner at regular intervals along their length as far as is possible. If, for any reason, tracks are unsupported over a significant length at a particular position (e.g. in order to bridge a gap in the floor), a detailed assessment by a competent person (e.g. structural engineer) should be undertaken to ensure that the tracks are not subjected to significant bending deflection. If this cannot be shown, a stronger track or additional support (i.e. bridging support) should be used.

NOTE Figure 3 shows the track beams and track gauge.

Figure 3 Track beams

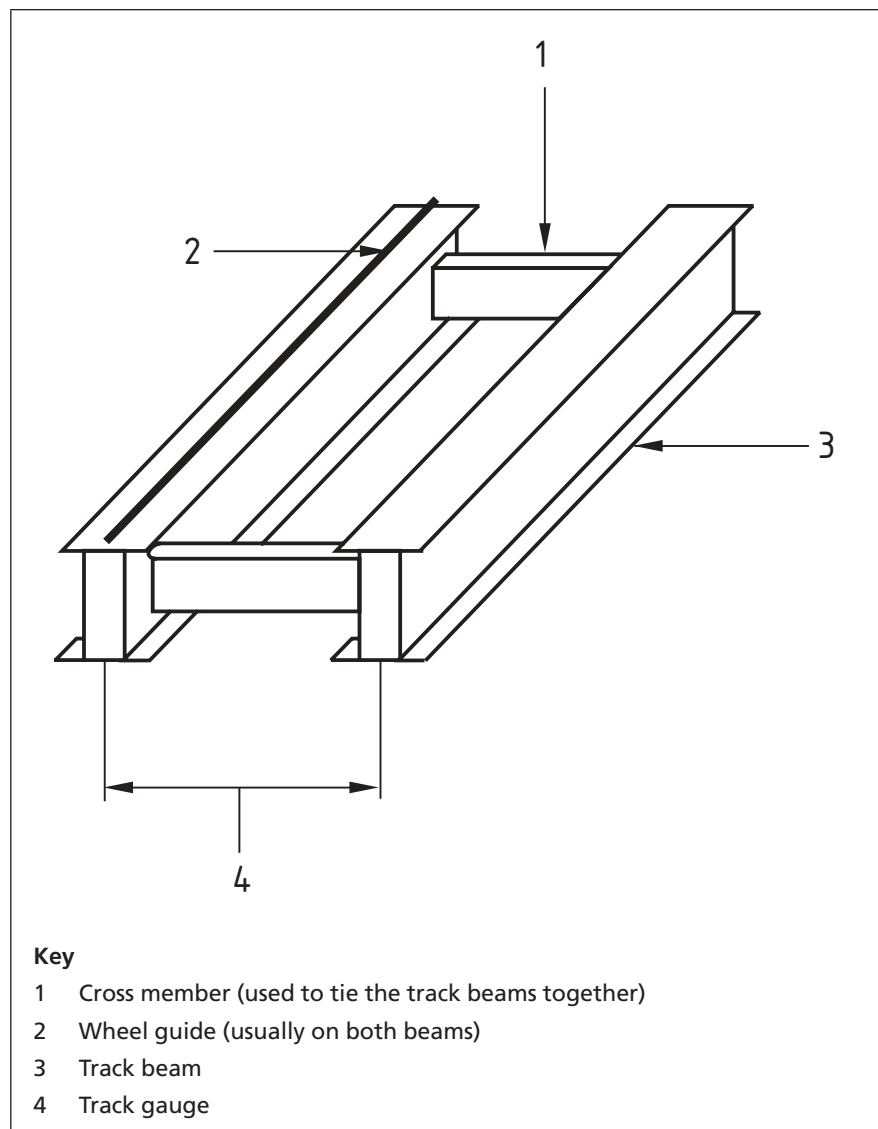

13.5.2 Jacking units

The HGLS lift supervisor should ensure that the jacking units are set up so as to be “plumb” within specified tolerances in both the vertical and horizontal planes.

NOTE Figure 4 shows details of a typical jacking unit. Figure 5 shows a jacking unit on the track.

Figure 4 Jacking unit details

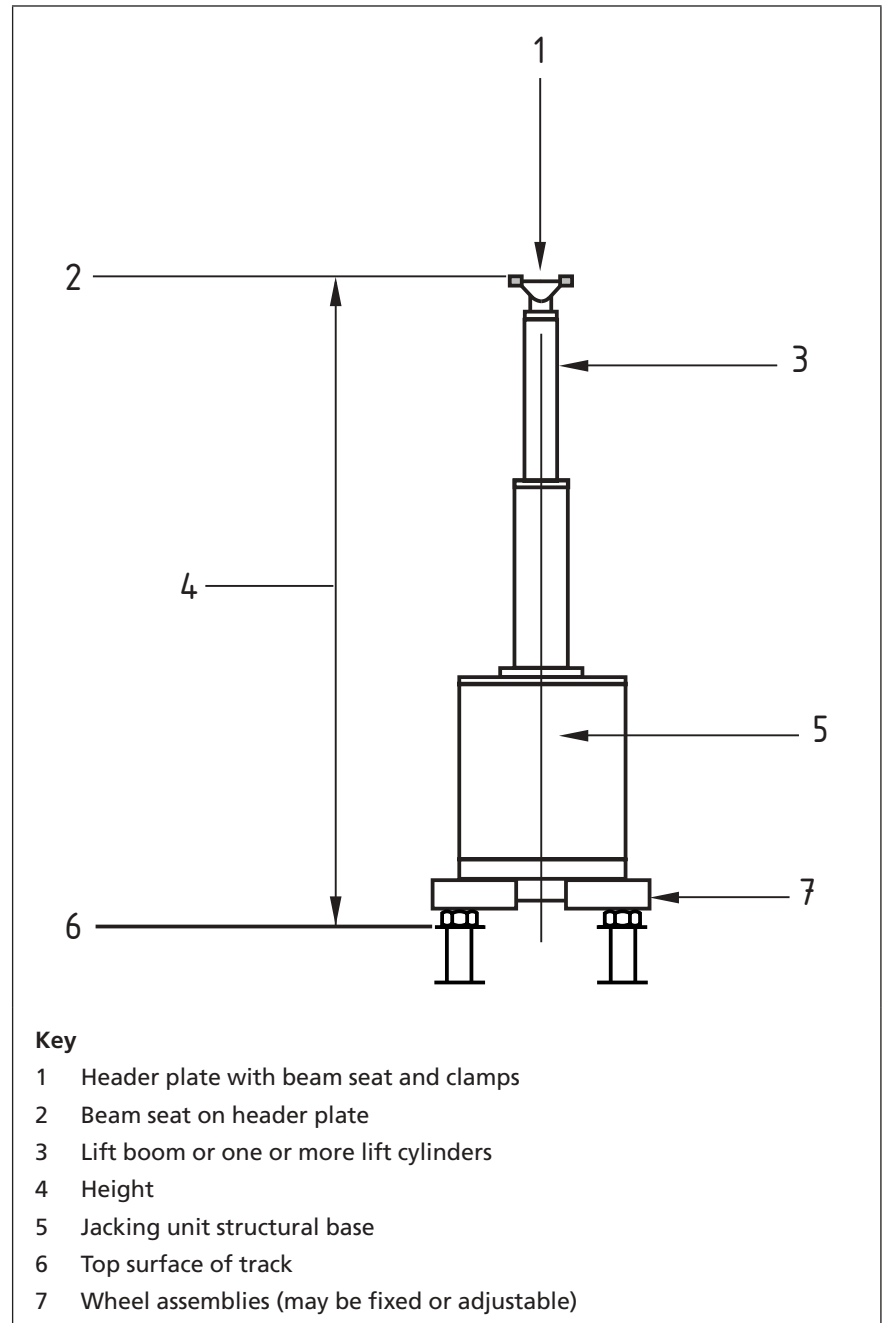
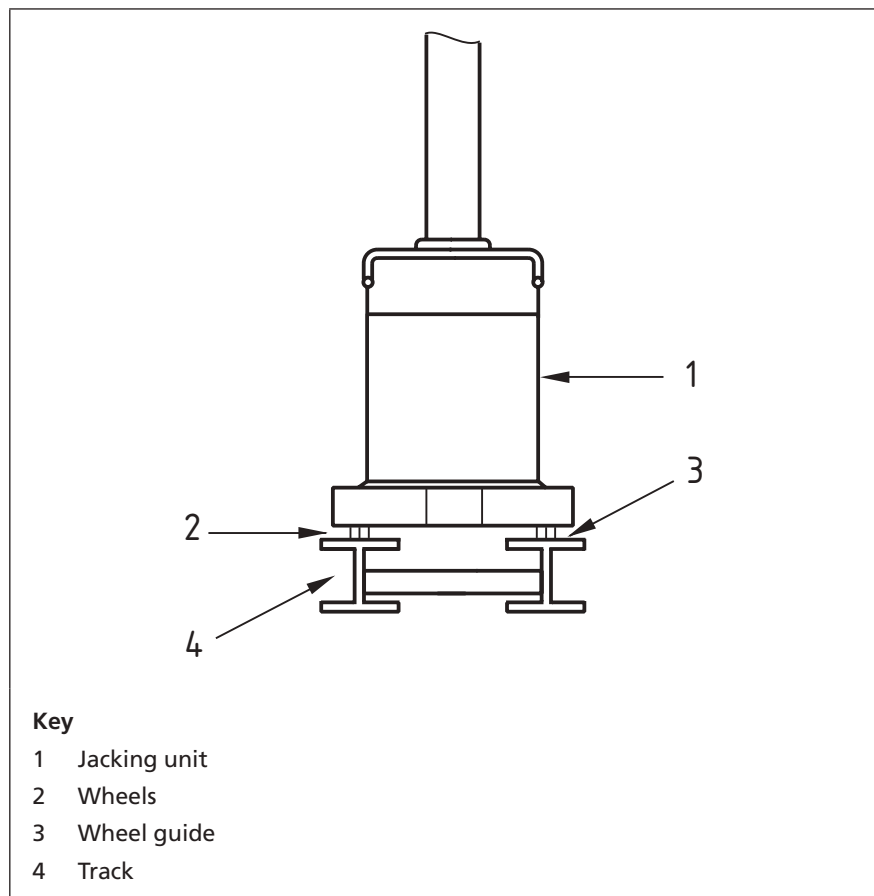

Figure 5 Jacking unit on track showing track wheel guide locations



13.5.3 Header and cross beams

The header and cross beams should be secured and suitably clamped into position (in HGLS models where this is required and allowing for some element of movement in the system). Associated nuts and bolts should always be systematically tightened to the value of torque specified.

NOTE 1 It needs to be ensured that the required rotation under load of the header beams and cross beams (if fitted) can be accommodated by the header plate swivel joint.

NOTE 2 Figure 6 shows details of header and cross beams. Figure 7 shows a typical lift link in relation to the header beam.

13.5.4 Control/power units/panels

The control/power units/panels should be placed side by side in a pre-determined area. The hydraulic oil should be checked and topped up, if required, with the designated fluid. Where possible, the control/power units/panels should be positioned so that the HGLS operator is able to view the lifted object and jacking units throughout the lifting process. For significant moves along a track, it might be necessary to move the control/power units/panels to different positions throughout the lifting operation.

Figure 6 Header and cross beams

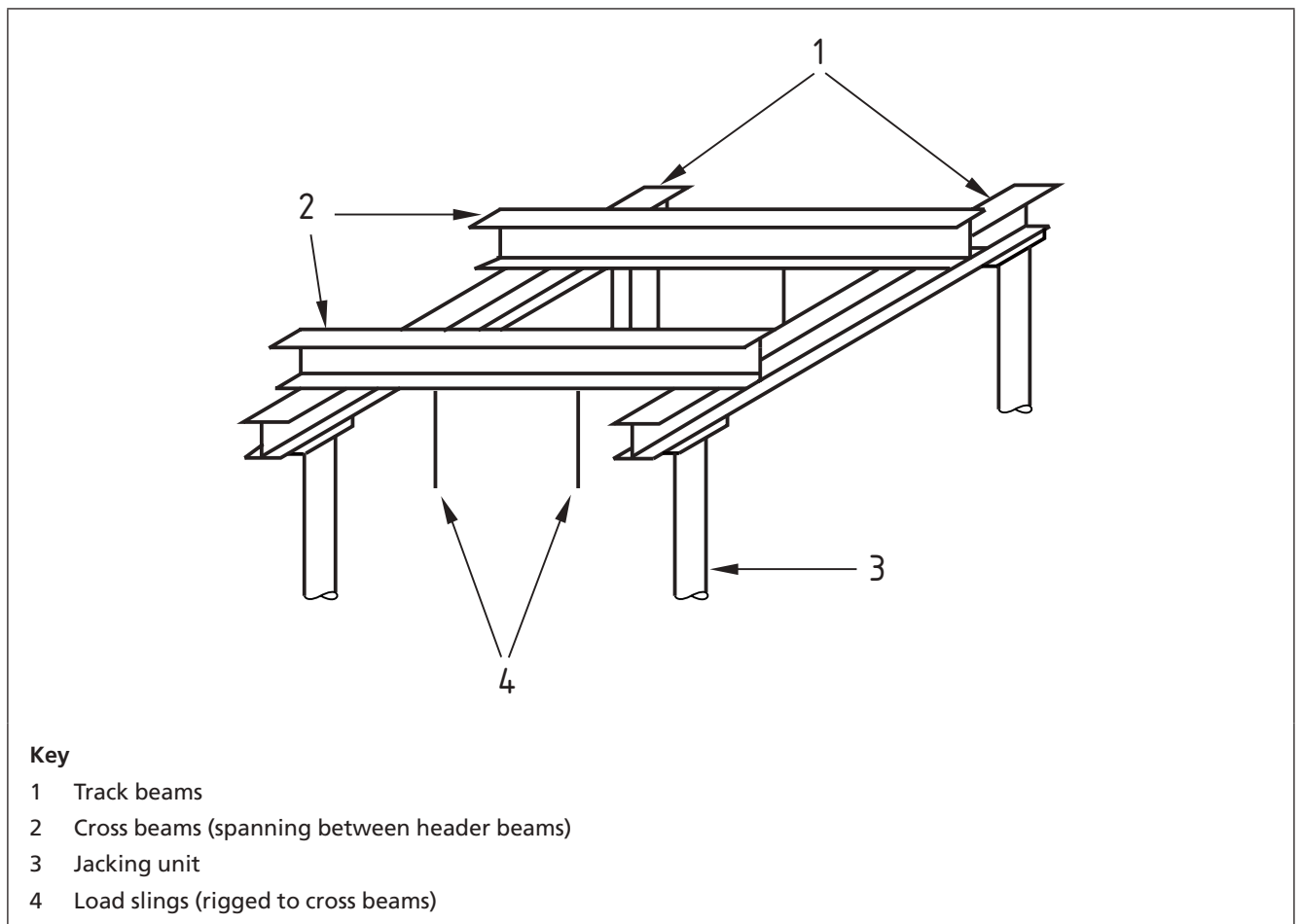

13.5.5 Hydraulic hoses

Hydraulic hoses to HGLS units usually have quick-fit couplings so that it is impossible to fit them to the wrong cylinder. The connections also give positive feedback when they are loaded in place. Locking couplings should be fitted in order to ensure that hose connections do not come apart if they are “dragged” during the operation. Hoses should be numbered accordingly and a visual check on them should be maintained throughout the lifting operation. Hose burst valves should also be incorporated.

13.6 Assembly inspection

The HGLS assembly should be carefully inspected once it has been erected. This inspection should include the checking of the horizontal and vertical attitude of the beams and tracks to ensure that they are within the prescribed tolerances. The tracks should be inspected to ensure that they are free of debris etc.

Figure 7 Typical lift link

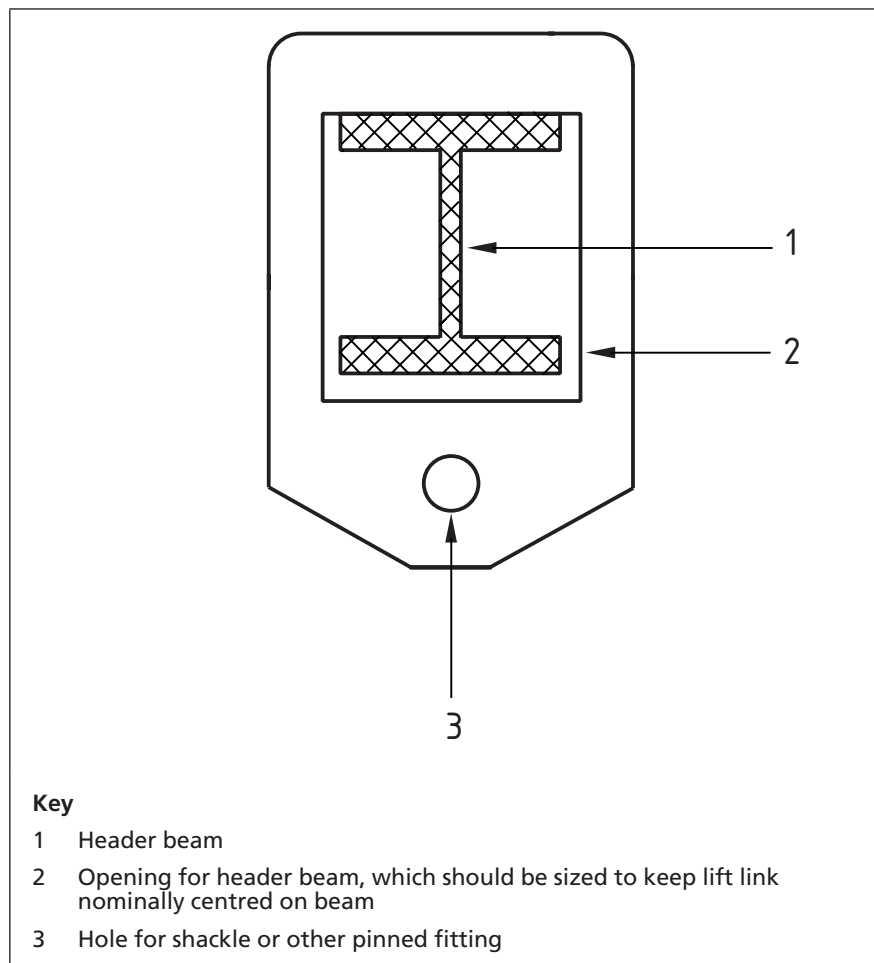

13.7 Pre-lift

Once the HGLS has been assembled and inspected, one test without the lifting object should be carried out followed by a test with the lifting object whereby it is lifted just off the ground or supporting surface and the height of each jack is measured to determine if they are lifting evenly (or the beam leveller devices, if fitted, are monitored). The lifting object should then be lowered back to the ground or supporting surface and the exercise ought to have confirmed whether all the lift cylinders are operating correctly or not. Checks for leaks, as well as other visual checks, should be made during the pre-lift test.

14 Procedures and precautions

14.1 HGLS operation

Whether or not an HGLS is lifting a load, it should only be operated by a competent person (usually the HGLS operator; see 7.2.2) nominated by the employing organization or by the authorized person acting on their behalf.

This should not inhibit a trainee operator being nominated in certain circumstances provided that the trainee is under the direct supervision of a competent operator (i.e. the HGLS operator) who has also been nominated for that purpose. However, only a trainee operator who is in the later stages of training should be considered for such nomination.

14.2 Working on HGLS assemblies

14.2.1 General

When personnel are required to work on HGLS assemblies for inspection, maintenance or other reasons, a system should be in operation to ensure that they are not endangered by any movement of the assembly and that a secure working place is provided (e.g. scaffolding, if appropriate).

The system can usually be by means of verbal communication (telephone or radio communication, if necessary) provided that it is clearly defined and readily understood by all personnel.

14.2.2 Periodic checks

Specific HGLS lifting operations are typically conducted over a short period of time (usually within one day). Rigorous periodic checks of the HGLS and associated equipment areas are not required therefore, provided that the assembly inspection (see 13.6) and pre-lift (see 13.7) stages have been satisfactorily carried out. During the lifting process, systematic checks should be made to ensure that:

- a) no significant distortion (e.g. torsion or bending) of the assembly is occurring;
- b) the header beams remain level within prescribed tolerances;
- c) no permanent movement of the tracks (if appropriate) has occurred;
- d) no significant oil leakage is evident;
- e) all relevant instrumentation and alarm systems are operating satisfactorily.

For cases where HGLS lifting operations could extend over a prolonged period of time, a more systematic checking procedure should be carried out as defined by the HGLS operator and relayed to the appointed person. For example, if the operation extends over several days, then it would be wise to repeat the assembly inspection and pre-lift stages at the start of each day as well as undertaking the checks associated with list items a) to e) in this subclause.

14.3 Reporting of defects and incidents

The appointed person should ensure that there is an effective procedure for reporting defects and incidents. The procedure should include notification to the appointed person for the recording of action taken to rectify any defects and clearances of the HGLS components for further service.

The procedure should include the immediate notification of the following:

- a) any defects found during “in-operation” checks;
- b) defects found at any other time;
- c) incidents or accidents, however slight;
- d) shock loads, however they occur;
- e) dangerous occurrences or reportable accidents.

The procedures should include provision for an examination by a competent person after any incident, whether or not a repair is necessary, to ensure that the HGLS component is fit for further service.

14.4 Leaving the HGLS unattended

The staging of a lift should be planned such that a suspended lifting object is never left unattended.

14.5 Maintenance

14.5.1 General

Provision should be made to ensure that, throughout their use, the HGLS components and other equipment used in the lifting operation are maintained in a satisfactory condition.

The appointed person should be satisfied that adequate information (e.g. manufacturer’s instructions) is available and that the maintenance is carried out by trained personnel who have adequate knowledge of the correct procedures (see 7.2.4 and 8.4). The frequency and extent of such maintenance should take account of all factors that affect the HGLS in carrying out its required work.

Moving parts (such as the swivel fitting of the adapter plate) should be greased at regular intervals. The wheels on the jacking unit and tracks (particularly any weldments) require particular attention in terms of inspection.

In general, the HGLS components should be examined on their return to their storage premises following a lifting operation.

14.5.2 Storage

The storage arrangements for equipment can significantly affect the way it is maintained. In particular, care should be taken to ensure that equipment is stored so as to minimize the possibility of water ingress, leading to corrosion. To this end, the jacking units and control/power units should be stored inside a suitable building, or, if they have to be stored outside, they should at least have a suitable cover over them. It is also desirable for the other components to be stored under suitable covering. Possible deterioration of the environment in which equipment is stored should always be considered.

14.5.3 Planned maintenance

To ensure safe and satisfactory operation of the HGLS, a properly planned maintenance system should be established and used.

Planned maintenance should include regular calibration of the pressure gauges in a way that is consistent and repeatable.

Other specific maintenance tasks should be carried out at stated intervals as recommended in the manufacturer's instruction books, and these periods should not be exceeded. The manufacturer's instruction books should also be referred to for recommendations on the lubrication points that require attention, the interval or frequency of greasing and oil changes, and the grades and quality of lubricant to be used.

A record (see 11.8.4) should be kept of the major components comprising the HGLS model. The availability and source of replacement items should be checked and recorded. Consideration should be given, where appropriate, to stocking certain expendable items and other parts to minimize downtime in the event of component breakdown.

NOTE The statutory thorough examination of the HGLS requires a competent person to assess whether or not the HGLS components are fit for service at the time of the examination. The examination does not cover the absolute legal requirement to ensure that the equipment is properly maintained, which involves carrying out a more frequent inspection that takes account of the frequency of use of the HGLS and associated equipment and the environmental conditions.

An effective planned maintenance system should recognize the possible need to prohibit the use of the HGLS until essential maintenance work is carried out.

14.5.4 Replacement components

Only components conforming to the manufacturer's specification should be used as replacement components.

14.5.5 Use of materials for repairs

If it is necessary to carry out repairs to any parts of the HGLS's components, information should be sought from the manufacturer regarding the correct procedure and this should be strictly adhered to. In particular, excessive heat that can change the properties of the steel should be avoided.

15 Operating conditions

15.1 Rated capacity

The rated capacity of the HGLS should not be exceeded other than for the express purpose of testing the HGLS within the criteria specified under LOLER [1] under the supervision of a competent person and/or the HGLS operator.

15.2 Operation and control

15.2.1 General

To ensure safe use of the HGLS, each control (e.g. the levers controlling each lift cylinder) should be marked to identify the motion controlled and the direction of movement (up or down in the case of the lift cylinder control). Markings should be in English and consist of internationally agreed symbols.

On no account should the HGLS operator or other personnel tamper with any controls, mechanisms or equipment, either to enable the HGLS to function outside the operational range or loads specified by the HGLS manufacturer or other competent person, or to attempt to correct any suspected defect (see **14.3**).

Before starting any lifting operation with an HGLS, the following should be observed.

- a) The HGLS operator should be familiar with the controls and layout.
- b) The HGLS operator should have a clear and unrestricted view of the lifting object and operational area or should act under the directions of other authorized personnel (i.e. HGLS slingers/signallers) positioned to have a clear and uninterrupted view. It is particularly important that the HGLS operator ensures that lifts can be carried out without causing damage.
- c) Where telephone, radio or CCTV communications are being used, the HGLS operator should ensure that the calling signal is functioning satisfactorily and that verbal messages can be clearly heard.

When starting up the control unit, sufficient time (several minutes) should be given for the oil to warm up since it needs to be up to temperature for correct pressure-load calibration. It is recommended that the various checks to the HGLS assembly are performed during this "warm up" time. Oil levels should have been checked prior to this stage and, through good maintenance, the equipment should be in good working order at this point.

Lifting accessories (slings and shackles) can be attached to the header beams after the HGLS has been assembled. Alternatively, and especially for heavy lifts, it might be more appropriate for the lifting accessories to be attached while the beams are still at floor level prior to HGLS assembly. It is noted that all lifting accessories should have a test certificate. Header beams generally need to be tested by a certifying authority and written information (e.g. by way of suitable charts) should be provided to show weight limits at different points (allowing for different lengths of span between jacking unit pairs).

It is important that any constraints within the workplace do not encourage any shortcuts in the planning and execution of the lifting operation (e.g. low roof, obstructing objects resulting in an inability to lay the track as required).

Careful monitoring of the pressure gauges should be observed at all times throughout a lift and clear user-friendly pressure-load conversion information should be readily available to the HGLS operator. The lifting area should also be cordoned off with tape to stop personnel approaching and/or to identify danger areas (e.g. a hole left following removal of the lift time). Physical barriers, such as fences and scaffolding, can also be used for this purpose.

As described in **13.7**, the lifting object should initially be lifted just clear of the ground or supporting surface. It should be returned to the ground or supporting surface and brought to rest. The HGLS should then be checked, before proceeding further. Proper care should be exercised by the HGLS operator at all times to avoid shock or side loadings being applied to the system.

While the object is being lifted, care should be taken to ensure that the HGLS operator and other authorized personnel (e.g. HGLS slingers/signallers) are not distracted by other personnel or activities (e.g. machinery) within the vicinity of the lift site.

In taking up the slack in the lifting accessories (i.e. slings), care should be taken to ensure that the lifting object is being lifted evenly. If not, it should be lowered to the ground or supporting surface and appropriate adjustments made before lifting again.

In assessing the system in the early stages of a lift, it is important to realize that the system might take a little time to settle. The clearance above the ground and alignment of the tracks and jacking units etc. need further checking as the job proceeds. Unusual sounds emanating from the system should be investigated. If there has been a significant delay between setting up the equipment and performing the lift, then further checks (see 14.2.2) should be made to ensure that the HGLS equipment has remained unchanged since the previous inspection. It might be useful to mark (with spray paint, for example) the jacking units and/or tracks in order to detect any unintentional movement which might occur.

The height of each header plate should be monitored by a simple linear measuring device. Height checks should be made every metre to ensure that the cylinders are extending evenly. For high lifts, checking should ideally be every 100 mm to 200 mm and beam levelling monitoring devices should be fitted and used.

The hydraulic and electrical control should be switched off after the lifting operation has been completed.

The HGLS safety device should not be regarded as the routine means of stopping motion(s).

If a safety device is activated, the lifting object should be brought safely back down to the ground or supporting surface. The safety device should be reinstated by a competent person and a record of the event should be compiled.

15.2.2 Straight up and down lift

A simple straight up and down lift with an HGLS configuration requires significant attention to planning and supervision as it is essentially a multiple lifting operation, necessitating the use of more than one (usually two or four) jacking units. Lifting operations should therefore be planned with extreme care (see Clause 6) and should include an accurate assessment of the load to be carried by each jacking unit.

The total mass of the lifting object and its distribution should be either known with confidence or calculated. Where the information is taken from a drawing, due allowances should be made for casting and rolling margins and manufacturing tolerances.

The centre of gravity should be evaluated as accurately as possible. However, owing to the variable effect of manufacturing tolerances and rolling margins, quantity of weld metal etc., the centre of gravity might not be accurately known for some lifting loads. The proportion of the load being carried by each HGLS jacking unit might therefore be uncertain. Such uncertainty needs to be taken account of in the planning stage.

The mass of the lifting gear should be part of the calculated load on the HGLS assemblies. When handling heavy or awkwardly shaped loads, the deduction from the rated capacity(ies) of the HGLS jacking units to allow for the mass of the lifting accessories might well be significant. The mass of the lifting accessories, and hook blocks where appropriate, and their distribution should therefore be accurately known.

The distribution within the lifting accessories of the forces that arise during the lifting operation should be established. The lifting accessories used should, unless specially designed for the particular lifting operation, have a capacity margin well in excess of that needed for their proportional load. Special lifting accessories might be necessary to suit the maximum variation in distribution and direction of the application of loads or forces that might occur during the lifting operation.

If the variations in the direction and magnitude of the forces acting on the HGLS configuration during the lift are to be kept to a minimum, the HGLS motions should be synchronous in their effects. Jacking units of equal capacity and similar characteristics should therefore be used where possible.

If the appointed person is satisfied that all the relevant factors referred to here have been accurately identified, and are being monitored by appropriate instrumentation and/or other methods, the HGLS jacking units may be used up to their rated capacities. When all the factors cannot be accurately evaluated, a worst case scenario should be considered and HGLS equipment selected accordingly if the HGLS operator and the appointed person are satisfied.

15.2.3 Straight up and down lift with longitudinal travel

As noted in 3.19, there are three basic methods available on HGLS to propel the jacking units along tracks. The external cylinder method is the most common one used. To set up this propel action, pins are located in order to couple the propel cylinder to the track (the propel cylinder should already be attached to the jacking unit). The switch from lift to traverse mode can either be an electrical device or a handle on the jacking unit. The hydraulic hoses should have been attached to the propel cylinders by this stage. The jacking units are traversed by extending and contracting the propel cylinders.

The pins, in order to couple the propel cylinder to the track, should be located by one or more of the HGLS slingers/signallers. The HGLS operator and HGLS slingers/signallers should communicate to each other on this aspect (e.g. by hand signals). In traversing the jacking units, care should be taken to ensure that they are moved evenly such that the chances of introducing torsion and bending loads into the system are minimized. Suitably designed end stops should be put in place to ensure that the HGLS cannot go off the tracks. It is suggested that the jacking units are connected by adjustable connection links, where practicable. However, it is recognized that lifts of very long loads might preclude mechanical connections and should be left to the judgement of the appointed person and included in the lift planning.

NOTE Figure 8 shows the propel cylinder attachment.

Figure 8 Propel cylinder attachment

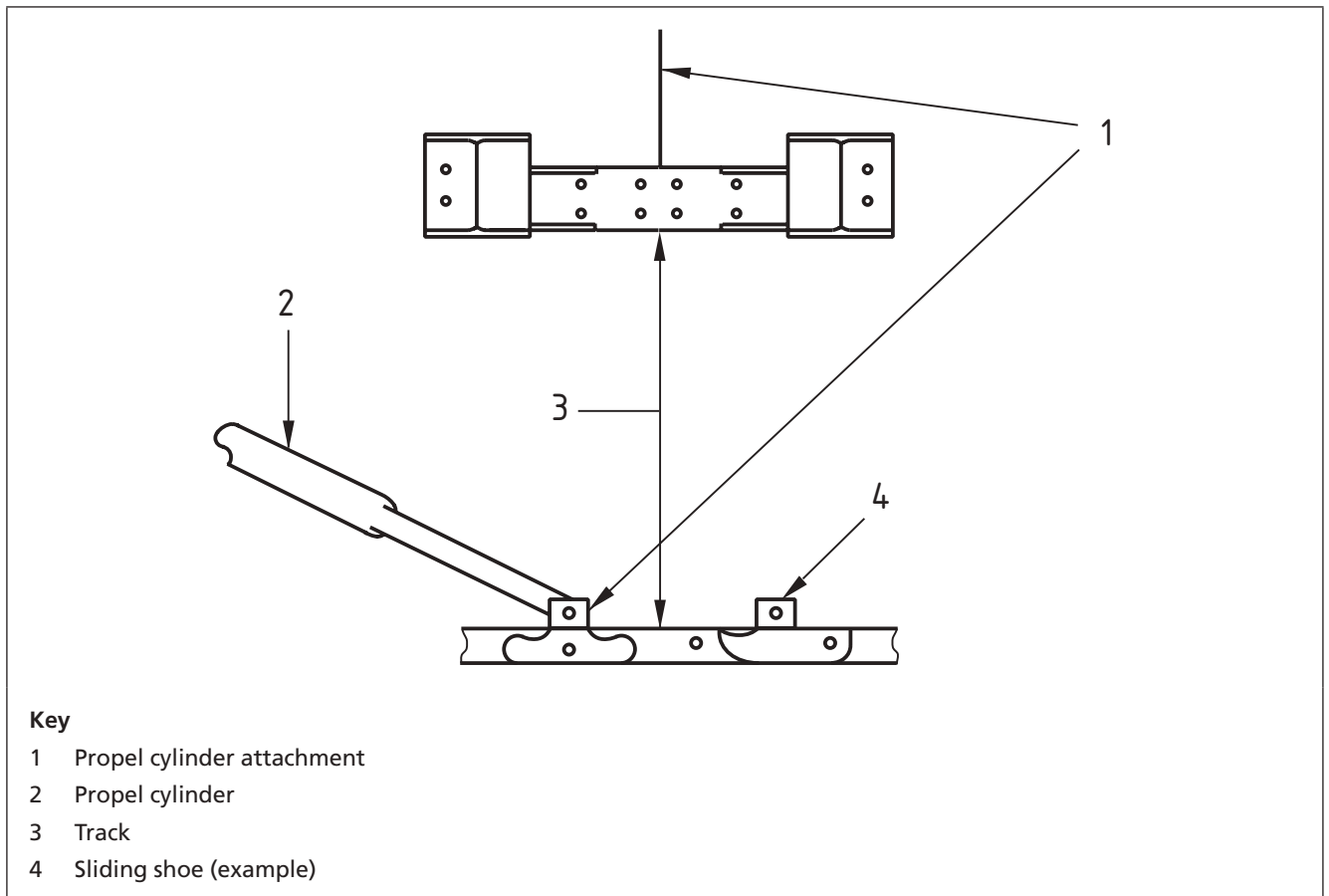

15.2.4 Top and tail lift

For performing a top and tail (stand up/lay over) lift, additional consideration should be given to determining the correct length of lifting accessories (long set and short set slings) and their rating. The latter is necessary because the load shifts to one set of lifting accessories.

Particular care is necessary when the lifting object load moves from one set of lifting accessories to the other. In fact, the movement in the position of the centre of gravity throughout the entire operation is particularly significant as sudden movements induce significant (indeterminate) dynamic loadings.

In performing a top and tail lift, it should be appreciated that the jacking units move towards each other if the lifting object is being lifted from "horizontal" to "vertical" position and move away from each other if the lifting object is being lowered from "vertical" to "horizontal" position. During a top and tail operation, the wheels in both pairs of jacking units should remain free to move. It is considered bad practice to lock any pair of jacking units during such an operation since this can lead to significant side loads being placed on the hydraulic cylinder(s). It is essential that this information is detailed in the method statement.

Height checks should be made every 300 mm for a top and tail operation. As noted previously, such checks should be carried out by means of a simple linear measuring device and beam levelling monitoring devices should be fitted and used.

If, for any reason, an overload situation arises during a top and tail lift, the lifting object should be brought down to the ground or supporting surface. If this is considered to be difficult to achieve in a safe manner, the telescopic cylinders in each pair of jacking units should be adjusted (i.e. raised or lowered) so as to transfer the load to be more equally distributed between the jacking units.

15.2.5 Side shifting lift

Moving the lifting object in the lateral direction is the least common task performed by an HGLS. Movements are likely to be very small, however, and might be required for positioning an item into keys, for example. Cross travel on a beam should only be carried out using proper optional equipment. This may be in the form of hydraulically propelled skates built into the lifting links, a rack and pinion travelling device or push/pull hydraulic cylinders and a cable winch. The lifting object should always be positively restrained on the beam and never free to roll should an out-of-level situation occur. End stops should be fitted to prevent the lifting object being pushed beyond the end of the beam.

15.2.6 Combination lift

Consideration should be given to any equipment used in combination with the HGLS to carry out the lifting operation (e.g. forklift, mini-crane, mobile crane or machine skates). It is important that the use of any equipment other than the HGLS is properly planned and supervised and a safe system of work is detailed in the method statement.

15.3 Handling of loads near persons

Only the HGLS operator, HGLS lift supervisor, HGLS slingers/signallers and appointed person of the employing organization should be in the vicinity of the lifting operation. They should stand clear of the lifting area.

15.4 Weather conditions

15.4.1 General

The operation of an HGLS in situations where it is likely to be affected by the weather should be given careful consideration. Certain weather conditions such as strong wind, heavy rain, ice or snow can impose loads on an HGLS and adversely affect the safety of operation.

NOTE Guidance on the evaluation of wind loads is given in BS 2573-1. Relevant information is also contained in BS 6399-2.

A lift either should not be started or should be terminated if the weather conditions or lighting are not sufficient.

15.4.2 Wind

The HGLS should not be operated in wind speeds that are in excess of those which have been specified in the method statement for the particular configuration of HGLS and geometrical properties of

the lifting object. Gusting wind conditions might have an additional adverse effect on the safe handling of the lifting object and the safety of the HGLS. Even in relatively light wind conditions, extra care should be taken when handling loads presenting large wind-catching areas. This should be included in the method statement.

The limitation on wind speed for erecting, testing and dismantling the HGLS might be lower than the limitation for normal operation, and, in cases of doubt, the manufacturer's or a competent engineer's advice should be obtained.

15.4.3 Wind speed indication

In the case of an HGLS operating in positions where it might be adversely affected by high winds, an anemometer should be mounted at a suitable high point, preferably on one of the header beams.

15.4.4 Visibility

In poor visibility, suitable means of communication should be provided to ensure the safe operation of the HGLS. In extreme conditions, HGLS operations should be stopped until there is sufficient improvement in visibility to enable operations to be resumed safely.

15.4.5 Rain, snow or ice

During adverse weather conditions, the appointed person, in consultation with the HGLS operator, should ensure that adequate precautions are taken to avoid danger when the HGLS or the lifting object is affected by rain, snow or ice.

16 Slinging and handling of loads

16.1 Mass and centre of gravity of the load

16.1.1 Mass

The mass of the load to be lifted should be known to a reasonable accuracy. The mass should be determined by any of the following procedures.

- a) Look to see if the mass is marked on the load. If it is, check to ensure that it is the mass of all parts of the load (a machine tool, for example, might not include the drive motor).
- b) Check the mass stated on any documentation.
- c) Look at a drawing of the load. If the mass is marked, check in the same way as in item a) to ensure it includes all parts of the load.
- d) If the load is still on a trailer or truck, use a weighbridge.
- e) Estimate the mass of the load by using tables of masses. BS 4-1 gives the mass of rolled steel sections and Table 1 gives masses for other materials.

Table 1 Mass of materials

Material	Mass	Mass
	kg/m ³	lb/ft ³
Aluminium	2 700	170
Brass	8 500	530
Brick	2 100	130
Coal	1 450	90
Concrete	2 400	150
Copper	8 800	550
Earth	1 600	100
Iron and steel	7 700	480
Lead	11 200	700
Magnesium	1 750	110
Oil	800	50
Paper	1 120	70
Water	1 000	62
Wood	800	50

NOTE 1 In some cases the values given are an average and the actual mass might vary according to the particular composition/water content, etc.

NOTE 2 All values have been rounded for convenience of use.

NOTE 3 When dealing with a hollow body, check whether or not it contains anything and whether or not any such contents are liable to move.

16.1.2 Centre of gravity

16.1.2.1 General

The centre of gravity of the load should be known. This is the point at which the total mass of the load is regarded as being concentrated, i.e. the point about which the parts of the load exactly balance each other.

16.1.2.2 Regularly shaped load(s)

With a regularly shaped load (e.g. a rolled steel joist), the centre of gravity can be easily judged by measuring the midpoint in each direction.

16.1.2.3 More complex-shaped loads or irregularly shaped loads

For more complex shaped loads, it might be necessary to estimate the centre of gravity of the various parts of the load and then combine them to get a centre of gravity for the whole.

16.2 Use of lifting accessories/attachments

Only slings and other lifting accessories/attachments for which a valid report of thorough examination (and, if produced, a valid test certificate) has been issued within the previous six months or in accordance with a scheme of thorough examination should be used.

Lifting accessories/attachments should be clearly marked with the rated capacity and an identification number (for record purposes).

Lifting accessories/attachments should be visually inspected on each occasion before use.

When not in use, such lifting accessories/attachments should be stored in secure dry conditions, preferably by hanging on a rack where they cannot get tangled, wet or contaminated by dirt, grease, concrete etc.

Lifting accessories/attachments should be released from the store only on the instruction of a person in charge of them.

Under no circumstances should slings be knotted.

When used in connection with the handling of molten metal or slag, the rated capacity of all lifting accessories/attachments should be de-rated to half the normal rated capacity.

Checks should be made to ensure that the lifting accessories/attachments can withstand the environment in which they are to be used, and that they have been protected from mechanical damage and other hazards such as heat, cold or corrosive substances.

Under no circumstances should chains be joined by means of bolts or wire, and when shackles are used the correct pins should be fitted.

Lifting accessories/attachments should not be dragged along the ground or floor.

NOTE The Code of practice for the safe use of lifting equipment [10] provides further information regarding the selection and use of equipment.

16.3 Signalling systems

Copies of the code of hand signals to be used should be issued to all HGLS lift supervisors, HGLS operators, HGLS slingers and other personnel involved in the carrying out of a lifting operation to ensure that a universal signalling code is used.

In situations where hand signals alone are inadequate, other forms of communication should be used, by means of either radio or telephone, to supplement the hand signal code.

When radio is used as a means of signalling, the channel selected should be kept clear of all other communications. All personnel involved in the signalling should be given a clear and unique call sign, and all communications should be preceded by this call sign. The HGLS operator should not respond to any command that is not preceded by the given call sign.

During the carrying out of the lifting operation, hand signals and any voice instructions to the HGLS operator should only be given by one person at a time.

17 Thorough examination including testing

17.1 General

17.1.1 Thorough examination

A thorough examination should be understood to mean the following:

- a) a detailed examination by a competent person that is sufficient to ensure that the HGLS jacking units, associated components and equipment are safe for use;

NOTE 1 When considered necessary by the competent person, visual examination can be supplemented by methods of non-destructive testing that determine the condition of any part of the HGLS without causing any detrimental change to the materials.

- b) when considered necessary, dismantling of parts of the HGLS configuration by a skilled person to the extent required by the competent person.

The HGLS should be thoroughly examined by a competent person prior to use to ensure that the equipment is safe to use. In addition, thorough examination might be necessary following any substantial alteration or repair to the HGLS. Lifting accessories to be used with the HGLS should also have been thoroughly examined. This is generally done separately from the HGLS.

NOTE 2 In practice, individual HGLS or components are often thoroughly examined prior to assembly. This allows individual parts to be examined in more detail away from the lifting environment. The primary purpose of this examination is to detect any deterioration of the equipment that might affect the safe operation of the equipment. Once assembled, the competent person ought to undertake a second thorough examination of the completed assembly. The purpose of this second examination is to check that the HGLS has been assembled correctly in accordance with the manufacturer's and appointed person's instructions and that the equipment has not been damaged during transportation or assembly.

17.1.2 Reports of thorough examination, test certificates and documentation for HGLS operations

The following should be taken into account.

- a) An individual HGLS or components should not be used unless they have a current report of thorough examination.

NOTE 1 New HGLSs and components need to be CE marked and supplied with a declaration of conformity to the Machinery Directive [11].

Thorough examination is also required following substantial repairs or alterations, and/or periodically as deemed necessary by a competent person.

NOTE 2 Attention is drawn to the LOLER [1] for thorough examination, declaration of conformity and test certificates.

- b) In service inspections, systematic maintenance, repairs and renewals should be carried out and recorded.
- c) The rated capacity should be clearly marked on the HGLS jacking units and/or on charts affixed to the control panel(s).

- d) Header beams, cross beams and other appropriate components and attachments should be clearly marked with their rated capacity.
- e) A copy of the operating instructions should be with the HGLS.
- f) All reports of thorough examination, test certificates and records related to items a) to e) should be available for inspection (see 11.8.4).

17.1.3 Test site

Careful consideration should be given to the conditions (e.g. environmental conditions, including weather) of the test site. It should be remembered that recommendations given in the operating instructions or elsewhere for the HGLS relate to operations within the rated capacity. Requirements, which might in certain cases be statutory, apply when loads are being applied for testing. The information should be provided by the employing organization or the appointed person acting on its behalf.

17.2 Conduct of tests

17.2.1 General

The tests should be carried out under the control of the competent person (usually the HGLS lift supervisor) appointed for this purpose, who should clearly indicate when the tests start and when they have been completed. During the tests the other personnel involved (usually the HGLS slingers/signallers) should accept instructions only from the HGLS lift supervisor.

Immediately prior to the tests, the competent person should ensure by thorough examination (see 17.1.1) that the appropriate HGLS equipment is:

- a) free from any defect that would preclude it from safely handling the test lifting object;
- b) in the correct configuration and condition according to the manufacturer's instructions.

The HGLS lift supervisor and appointed person should also ensure that the site and weather conditions are suitable (see 17.1.3).

Shock loading, which might be caused by rapid acceleration of HGLS motions, erratic or sudden movement of the controls, should be avoided.

WARNING. At the completion of the test and thorough examination, all safety devices should be restored and checked to ensure that they function correctly.

17.2.2 Overload testing

Testing of the HGLS by the application of loads in excess of the specified rated capacity should only be carried under the direction of a competent engineer at a suitable test facility (see 17.1.3).

Overload testing is not normally undertaken during the thorough examination. It should only be undertaken when specified by the competent person carrying out the thorough examination of the equipment.

17.3 Thorough examination after test

A thorough examination (see 17.1.1) should be carried out by a competent person to ensure that the HGLS configuration has withstood the test loadings without signs of structural damage that affect the safety of the HGLS, such as the following:

- a) cracking;
- b) permanent deformation;
- c) paint flaking;
- d) loosening of, or damage to, structural connections.

The examination should confirm that all mechanisms function correctly and are free from defects.

17.4 Records

After any test or examination the results should be recorded. If, for any reason, the competent person considers it necessary to restrict the use of an HGLS (e.g. size limitations prevent the testing of the full range of duties of the HGLS), the restrictions should be noted on the report and the use of the HGLS should be subject to these restrictions. The markings/tables of rated capacity on the HGLS should be amended to reflect these restrictions.

Annex A (normative) **Training of appointed persons and HGLS lift supervisors**

A.1 General

The employment of a competent person to manage lifting operations is one of the most important factors in the safe use of an HGLS. Poor management, including planning and supervision, is a contributory cause of HGLS accidents, which can result not only in significant damage to plant, but also in severe injury to those doing the work or those nearby. Training enables suitable employees to learn the basic elements of managing HGLS operations. Following training, candidates should work under the supervision of an experienced appointed person until such time as their employer has assessed them as competent to perform their duties.

NOTE Detailed information about the content of training courses varies depending on the individual circumstances. The information provided in this annex will assist organizations running training courses, either internally or as a service to other organizations, to determine whether their courses are adequate.

A.2 Employer's duties

Training of personnel should be treated as an important element in the overall planning and supervision of safe lifting operations. Therefore, the employer should:

- a) use appropriate procedures to ensure that suitable trainees are selected (see **A.3**);
- b) provide adequate basic training in the role of the appointed person, including the principles of HGLS and lifting accessory selection, planning, supervision, operation, slinging, signalling, inspection, maintenance and thorough examination (see **A.4**);
- c) train employees in the identification of hazards on sites where lifting operations are to take place and the identification of control measures to reduce the level of residual risk;
- d) ensure that only employees who have been assessed as reaching an adequate level of competence are authorized to act as appointed persons (see **A.6**);
- e) provide adequate supervision so that the competence of appointed persons can be monitored and the need for any refresher training assessed.

A.3 Selection of appointed persons and HGLS lift supervisors

A.3.1 General

Potential appointed persons and HGLS lift supervisors should be carefully selected by the employer on the basis of their:

- a) prior relevant experience;
- b) academic and vocational qualifications;

- c) numerical ability and literacy;
- d) supervisory and management skills, and experience.

Selection tests may be used as part of the process.

A.3.2 Assessment of training needs

An assessment should be made of the extent of training which is needed for an individual, bearing in mind that this could be influenced by any previous training and experience. When potential appointed persons are recruited, it is essential that employers check that their qualifications and experience relate to the job they are to do. Where the type of HGLS to be operated or the slinging procedures to be used are outside the employee's previous experience, additional training should be provided. In any event, some further training is likely to be necessary to familiarize the employee with specific requirements of the new job.

A.4 Basic training of appointed persons

A.4.1 General

Basic training covers the principles, both theoretical and practical, governing the management of lifting operations with HGLSs.

A basic training course is usually designed with the requirements of novice potential appointed persons in mind but it would be unwise to assume that more experienced employees do not need basic training. Training organizations might acknowledge this and run short courses for those with experience, recognizing that less time is necessary for training in the fundamental aspects.

A.4.2 Training venue

Training should be given at a suitable facility. Where it is given at the employer's premises, it should be carried out independently of the trainee's normal work. This means that the instructor and trainee together with the HGLS and loads should, during the basic training, be wholly devoted to that training. A suitable facility would include:

- a) a segregated area set aside for the purpose of training;
- b) firm, level ground, which can take the weight of the HGLS and the intended loads;
- c) a site that offers a range of types of load, lifting accessories and simulated hazards;
- d) a suitable classroom environment.

A.4.3 HGLS available for training

An HGLS together with a competent HGLS operator should be available at the training venue for the exclusive use of the instructor and trainee for the purposes of training. The HGLS should have similar characteristics to the type the trainee will be managing after training. It should be in good condition, safe to use and accompanied by a current report of thorough examination and all appropriate instruction manuals.

A.4.4 Appropriateness of training

As far as possible, the instructor should ensure that the training provided covers the types of HGLS, the range of loads, lifting attachments, accessories and conditions likely to be met by the trainee, including any particular hazards met in normal operations. The employer should ensure that, if another organization carries out the training, it is made aware of the sort of work the trainee is likely to be doing.

A.4.5 Course structure

The course should be both theoretical and practical in nature and sufficient to enable the trainee to master the necessary skills.

The course should follow a carefully devised programme which ensures that each knowledge requirement is introduced at an appropriate point in the course, building from the simpler tasks and allowing adequate time for learning and practice before moving on.

A.4.6 Trainee/instructor ratio

It is important that the ratio of instructors and trainees suits the particular aspect of training being covered. There should be sufficient time for the instructor to demonstrate each part of the practical training and then for each trainee to practice the skills while also being able to learn from observing other trainees. A ratio of one instructor to four trainees should not be exceeded.

A.5 Training programme**A.5.1 General**

As a minimum, the instructor should follow a carefully devised, documented training programme covering the subjects given in **A.5.2** and **A.5.3** as relevant to the category of HGLS for which training is being given (see Table A.1).

NOTE As the course content for appointed persons and HGLS lift supervisors is very similar, organizations might elect to run one training course for both categories with separate final competency criteria.

Table A.1 HGLS categories

Category	Type of lifting operation
Basic	Static lift (Straight up and down, jack is stationary and does not travel)
Standard	Straight up and down lift with longitudinal travel
Complex	Top and tail lift Side shifting lift Combination lift (Any equipment used in combination with the HGLS to carry out the operation, e.g. forklift, mini-crane, mobile crane or machine skates) Multiple systems lift (More than four jacks or additional lifting equipment, e.g. strand jack)

A.5.2 Theoretical topics

Theoretical topics should include:

- a) an introduction to the course syllabus, with reasons for the importance of training;
- b) the relevant legal requirements, including those to do with HGLS maintenance, thorough examination, documentation, record keeping and use;
- c) the different responsibilities of all the individuals involved with a lifting operation;

NOTE 1 Reference could be made to relevant published material including British Standards and HSE and industry guidance;

- d) an introduction to different types of lifting equipment such as HGLSs, loader cranes, mobile cranes, crawler cranes, overhead travelling cranes and forklift trucks;
- e) a more detailed introduction to HGLSs, explaining the purpose of all main components, including the location and function of controls, instruments, indicators and safety devices;
- f) the principles of mechanical, hydraulic, pneumatic and electrical systems as they are relevant to the safe operation of HGLSs;
- g) pre-operational checks, reporting and operator level maintenance in accordance with manufacturer's instructions;
- h) site surveys, hazard identification and the completion of risk assessments and method statements;

NOTE 2 HGLS lift supervisors need to be able to understand a risk assessment and method statement, identify site-specific hazards and implement suitable control measures.

- i) the siting of the HGLS, including the assessment of strength and stability, and ground conditions, and the calculation of the distribution of the total load;

NOTE 3 Calculation of the distribution of the total load is not required for HGLS lift supervisors.

- j) the preparation of a drawing showing the area of the lifting operation, including the position of the HGLS and immediate hazards;
- k) the assessment of loads, including estimation of masses and centres of gravity, and their stability;
- l) lift categories, load complexities and environmental complexities;
- m) load charts and the selection of HGLSs for different duties;
- n) good operating practices, including operation near other plant equipment, precautions near overhead lines, structures etc.;
- o) communication with site managers, principal contractors and others in the area of the planned lifting operation;
- p) an introduction to the different types of lifting accessories, and their functions, limitations and reasons for possible failure;
- q) the routine care, inspection and maintenance of lifting accessories and reporting of defects. Information should be given on the criteria for rejection and actions to be taken;

- r) the selection and correct use of appropriate lifting accessories, including methods of slinging, the methods of rating for multi-legged slings, the concepts of working load limit and rated capacity, interpretation of markings and de-rating of lifting accessories for any particular adverse conditions of use;
- s) signalling methods, including the recognized code of hand signals;
- t) the briefing of lifting team members in the details of the lift plan.

A.5.3 Practical topics

Practical topics should include:

- a) carrying out a site survey and preparing a drawing showing the intended position of the crane;
- b) selecting suitable HGLSs for different lifting operations;
- c) undertaking the elementary operation of all controls under "no-load" conditions;
- d) assessing loads, HGLS lifting duties and correct lifting accessories;
- e) preparing the risk assessment and method statement;
NOTE This is not required for HGLS lift supervisors.
- f) briefing the lifting team (HGLS slinger/signaller and HGLS operator) on the details of the lift plan;
- g) supervising the siting and setting up of the HGLS in preparation for the lifting operation;
- h) supervising the lifting operation;
- i) practising the roles of slinger (see A.5.4) and signaller;
- j) checking that the HGLS is left in a safe condition at the end of the lifting operation.

A.5.4 Training in slinging

Appointed persons and HGLS lift supervisors should be given training in slinging (see B.7) either because they need an appreciation of those skills or because they could be acting as the HGLS slinger during lifting operations.

A.5.5 Instructors

The success of any training depends largely on the effectiveness of the instructors. Training should be carried out by people who have been selected and trained for the purpose. Some information on their selection and training is given in A.7.

A.6 Appraisal and authorization

A.6.1 General

Continuous assessment of a trainee's progress should be made by the instructor during training to ensure the required standards are reached at each stage, monitored and maintained.

A.6.2 Appointed person and HGLS lift supervisor tests

Potential appointed persons and HGLS lift supervisors should also be assessed by means of theoretical and practical tests, which confirm their ability to perform their duties satisfactorily. The tests should include:

- a) a written test, including questions relating to:
 - health and safety legislation;
 - British Standards for safe use of cranes including HGLSs;
 - identification of site hazards;
 - assessment of loads;
 - HGLS selection;
 - assessment of ground conditions, and the calculation of the distribution of the total load;
 - selection of lifting accessories and attachments;
 - HGLS signals;
 - operational issues and the attachment(s) used during training;
- b) preparation of a lift plan for a theoretical lifting operation, including:
 - a drawing of the site showing all significant hazards and the intended position of the HGLS;
 - assessment of the load to be lifted;
 - details of the HGLS selected for the lifting operation;
 - details of the lifting accessories or attachments selected for the lifting operation;
 - a risk assessment and method statement.

NOTE Item b) is not required for HGLS lift supervisors.

A.6.3 Training records and certification

Trainees who have satisfactorily completed a training course should be awarded a certificate to that effect. The employee, or the employer on their behalf, and the accrediting body should keep records of training carried out and the results of tests undertaken.

A.6.4 Authorization of employees

Employers should give specific authorization to employees to act as appointed persons. Employers should be satisfied that the employee has had appropriate training and is competent to do the job.

A.6.5 Continuing assessment

Even after training has been completed and authorization given, a periodic assessment of personnel should be carried out to determine continued competence. Refresher training should be carried out routinely every five years. It might be required earlier, for example, in the event of long periods of inactivity.

A.7 Selection and training of instructors

A.7.1 General

Training should be carried out by instructors who are competent, carefully selected and trained for the purpose.

A.7.2 Previous experience

As training contains a lot of practical and theoretical work, instructors should have a minimum of two years of experience working as an appointed person with HGLSs. In addition, instructors should hold a qualification in instructional techniques, and current certificates for "HGLS appointed person", operation, slinging and signalling.

A.7.3 Instructor training course content

Instructor training should cover the following topics:

- a) principles of instruction, including classroom techniques and practice demonstration techniques;
- b) the systems and processes used by the accrediting body;
- c) instruction on delivering the topics covered in **A.5**.

A.7.4 Assessment

Assessments should include:

- a) theoretical assessments of the instructor's knowledge relating to standards and legislation affecting HGLSs, technical aspects of HGLSs, operational requirements, training standards and instructional techniques;
- b) practical assessments covering the operation of an HGLS, preparing and presenting practical and classroom lessons, the administration of practical operator assessments and producing assessment reports.

An instructor's competency should be reviewed annually and refresher training given, if needed.

Annex B (normative) Training of HGLS operators and HGLS slingers/signallers

B.1 General

The employment of competent, trained operators and slinger/signallers is one of the important factors in the safe use of an HGLS. Inadequate employee training is a contributory cause of HGLS accidents, which can result not only in significant damage to plant, but also in severe injury to those doing the work or those nearby. Training enables suitable employees to learn the basic elements of HGLS operation and slinging and signalling.

NOTE Detailed information about the content of training courses varies depending on the individual circumstances. The information provided in this annex will assist organizations running training courses, either internally or as a service to other organizations, to determine whether their courses are adequate.

B.2 Employer's duties

Training of personnel should be treated as an important element in the overall safe planning and supervision of lifting operations. Therefore, the employer should:

- a) use appropriate procedures to ensure that suitable trainees are selected (see B.3);
- b) provide adequate basic training in the principles of HGLS operation and slinging and signalling (see B.4 and B.7);
- c) train employees in the use of the particular equipment (HGLSs or lifting attachments) which they are expected to use, and instruct them in the jobs they are required to do and any particular hazards of the sites where they could work (see B.6);
- d) ensure that only employees who have been assessed as reaching an adequate level of competence (see B.8) are authorized to operate the HGLS;
- e) provide adequate supervision so that the competence of HGLS operators and HGLS slingers/signallers can be monitored and the need for any refresher training assessed.

B.3 Selection of HGLS operators and HGLS slingers/signallers

B.3.1 General

Potential HGLS operators and HGLS slingers/signallers should be carefully selected by the employer on the basis of appropriate criteria (see 8.2 and 8.3). Selection tests may be used as part of the process.

B.3.2 Assessment of training needs

An assessment should be made of the extent of training which is needed for an individual, bearing in mind that this could be influenced by any previous training and experience. When HGLS operators or HGLS slingers/signallers are recruited, it is essential that employers check

that their qualifications and experience relate to the job they are to do. Where the type of HGLS to be operated or the slinging procedures to be used are outside the employee's previous experience, additional training should be provided. In any event, some further training is likely to be necessary to familiarize the employee with specific requirements of the new job.

B.4 Basic training of HGLS operators

B.4.1 General

Basic training covers the principles, both theoretical and practical, governing the safe operation of a given category of HGLS (see Table A.1).

A basic training course is usually designed with the requirements of novice operators in mind but it would be unwise to assume that more experienced employees do not need basic training. Many training organizations acknowledge this and run short courses for those with experience, recognizing that less time is necessary for training in the fundamental aspects.

B.4.2 Training venue

Training should be given at a suitable facility. Where it is given at the employer's premises it should be carried out independently of the trainee's normal work. This means that the instructor and trainee together with the HGLS and loads should, during the basic training, be wholly devoted to that training. A suitable facility would include:

- a) a segregated area set aside for the purpose of training;
- b) firm, level ground, which can take the weight of the HGLS and the intended loads to be lifted;
- c) a suitable classroom environment.

B.4.3 HGLS used for training

An HGLS used for training should have similar characteristics to the type the trainee would normally use after training. It should be in good condition, safe to use and accompanied by a current report of thorough examination and all appropriate instruction manuals.

B.4.4 Appropriateness of training

As far as possible, the training should include practice in the range of loads and conditions likely to be met by the trainee, including any particular hazards met in normal operations. The employer should ensure that, if another organization carries out the training, it is made aware of the sort of work the trainee is likely to be doing.

B.4.5 Course structure

The course should be largely practical in nature and sufficient to enable the trainee to master the necessary skills.

The course should follow a carefully devised programme which ensures that each operation is introduced at an appropriate point in the course, building from the simpler, less hazardous tasks to the more

complex operations, allowing adequate time for learning and practice before moving on. At each stage the instructor should explain and demonstrate the operation and the trainee should then practice it under close supervision.

B.4.6 Multiple HGLS types

If there is a requirement to operate more than one category of HGLS (see Table A.1), training should be given for each type and, although this would not normally require a re-run of the complete basic training course, it should cater for the differences between categories and be sufficient for the HGLS operator to demonstrate competence.

B.4.7 Trainee/instructor ratio

It is important that the ratio of instructors, machines and trainees suits the particular aspect of training being covered. There should be sufficient time for the instructor to demonstrate each part of the practical training and then for each trainee to practice the skills while also being able to learn from observing other trainees. A ratio of one instructor to four trainees and one HGLS should not be exceeded.

B.5 Training programme

B.5.1 General

As a minimum, the instructor should follow a carefully devised, documented training programme covering the subjects given in **B.5.2** and **B.5.3**, as relevant to the category of HGLS for which training is being given (see Table A.1).

B.5.2 Theoretical topics

Theoretical topics should include:

- a) an introduction to the course syllabus, with reasons for the importance of training;
- b) the relevant legal requirements, including those to do with HGLS construction, maintenance, thorough examination, documentation, record keeping and use;
- c) the different responsibilities of all the individuals involved with a lifting operation;
NOTE Reference could be made to relevant published material including British Standards, HSE and industry guidance.
- d) an introduction to HGLSs, explaining the purpose of all main components, including the location and function of controls, instruments, indicators and safety devices;
- e) the principles of mechanical, hydraulic, pneumatic and electrical systems as they are relevant to the safe operation of the HGLS;
- f) pre-operational checks, reporting and operator level maintenance in accordance with manufacturer's instructions, which are within the trainee's responsibilities;
- g) risk assessments and method statements;

- h) siting of the HGLS, including an understanding of strength and stability, and ground conditions, and the distribution of the total load;
- i) the assessment of loads, including estimation of masses and centres of gravity, and their stability;
- j) the use and effect of lifting attachments;
- k) lift categories, load complexities and environmental complexities;
- l) good operating practices including operation near other plant equipment, precautions near overhead lines, structures etc.;
- m) signalling methods including the recognized code of hand signals;
- n) the assembly and dismantling of HGLS systems.

B.5.3 Practical topics

Practical topics should include:

- a) assembling and dismantling an HGLS system;
- b) undertaking pre-operation checks and maintenance, reporting defects and completing relevant records;
- c) following a safe system of work as detailed in a pre-prepared risk assessment and method statement;
- d) siting and setting up the HGLS in preparation for the lifting operation;
- e) undertaking the elementary operation of all controls under "no-load" and "load" conditions;
- f) assessing loads, HGLS lifting duties and correct lifting accessories;
- g) using the HGLS to lift and position loads in progressively more demanding situations, both for the HGLS and the HGLS operator, using as many configurations of the HGLS as is practicable, including travelling with a load (in the case of travelling systems);
- h) practising working with an HGLS slinger/signaller (see **B.5.4**).

B.5.4 Training in slinging and signalling

Most HGLS operators should be given training in slinging and signalling (see **B.7**) either because they need an appreciation of those skills or because they are likely to be acting as the HGLS slinger as well as operating the HGLS.

B.5.5 Machine-specific training

B.5.5.1 General

As HGLSs vary widely in the way they are operated and the circumstances in which they are used, the knowledge and expertise required by the HGLS operator varies accordingly. It should be recognized that an HGLS operator who is competent to operate one make and model of HGLS might not have the necessary knowledge and experience needed to operate other makes and models.

B.5.5.2 Appropriateness of training

It is essential that training is related to the knowledge and experience of the HGLS operator, to likely job hazards, and to the size and complexity of the HGLS itself. For example, operating a small HGLS used for a limited range of simple lifting operations is likely to require different training from operating a large HGLS capable of being used in different ways for various complex lifting operations and in different work locations.

B.5.6 Instructors

The success of any training depends largely on the effectiveness of the instructors. Training should be carried out by people who have been selected and trained for the purpose. Some information on their selection and training is given in **B.9**.

B.6 Job-specific training of HGLS operators

B.6.1 General

Job-specific training of HGLS operators can follow the completion of basic training. It should be tailored to the employer's needs and include the following elements:

- a) instruction in the operating principles and controls of the specific HGLS(s) to be used, especially where these relate to special attachments and loads;
- b) training on the use of equipment in the conditions the HGLS operator is likely to meet on the job, and on the particular work to be undertaken;
- c) training on the application, under normal working conditions, of the skills learned during the basic training. This should be carried out under supervision.

B.7 Training of HGLS slingers/signallers

B.7.1 General

The training of HGLS slingers/signallers (who may also be HGLS operators) should provide information and practical experience on principles relating to the inspection, care, maintenance, selection and use of lifting accessories.

B.7.2 Training equipment

There should be a good range of lifting accessories available including, where possible, any special purpose accessories which the employee is likely to use. The lifting accessories in use should be in good condition with a current report of thorough examination. Examples of faulty lifting accessories should be made available to the trainee for inspection purposes.

B.7.3 Training facilities

Suitable facilities and training aids should be made available so that the instructor can cover the theoretical and practical elements of the training.

B.7.4 Course duration

Sufficient time should be available to cover the subject adequately and to allow time for practical work.

B.7.5 Training programme**B.7.5.1 Theoretical topics**

Theoretical topics should include:

- a) an introduction to the course syllabus, with reasons for training;
- b) the relevant legal requirements and published guidance material;
- c) an introduction to the different types of lifting accessories, their functions, limitations and reasons for possible failure;
- d) the routine care, inspection and maintenance of lifting accessories and reporting of defects. Information should be given on the criteria for rejection and actions to be taken;
- e) risk assessments and method statements;
- f) the assessment of loads, including estimation of masses and centres of gravity;
- g) the selection and correct use of appropriate lifting accessories including methods of slinging, methods of rating for multi-legged slings, the concepts of working load limit and rated capacity, interpretation of markings and de-rating of lifting accessories for any particular adverse conditions of use;
- h) signalling methods, including the recognized code of hand signals;
- i) record keeping to the extent that it is the HGLS slingers' responsibility.

B.7.5.2 Practical topics

Practical topics should include:

- a) following a safe system of work as detailed in a pre-prepared risk assessment and method statement;
- b) assessing loads, including estimating weights, centres of gravity and lifting points;
- c) selecting lifting accessories for particular loads;
- d) using appropriate lifting accessories, including methods of slinging, methods of rating for multi-legged slings, the practical application of the concepts of working load limit and rated capacity, interpretation of markings and de-rating of lifting accessories for any particular adverse conditions of use;
- e) storing lifting accessories correctly after use;
- f) giving appropriate signals to the HGLS operator.

B.8 Appraisal and authorization

B.8.1 General

Continuous assessment of the trainee's progress should be made by the instructor during training to ensure the required standards are reached at each stage, monitored and maintained.

B.8.2 HGLS operator's tests

At the end of the training programme, HGLS operators should take a series of tests to confirm that the skills listed in **B.5** have been gained. The tests should include:

- a) pre-operational checks;
- b) theoretical assessments, including questions relating to health and safety, operational issues and the attachment(s) used during training;
- c) a practical assessment to demonstrate safe operation of the HGLS and to ensure the correct procedures can be carried out.

B.8.3 HGLS slinger/signaller's tests

HGLS slingers/signallers should also be assessed by means of theoretical and practical tests, which confirm their ability to perform their duties satisfactorily.

B.8.4 Training records and certification

Trainees who have satisfactorily completed a training course should be awarded a certificate to that effect. The employee, or the employer on their behalf, and the accrediting body should keep records of training carried out and the results of tests undertaken.

B.8.5 Authorization of employees

Employers should give specific authorization to employees to operate HGLSs and/or to act as HGLS slingers/signallers. Employers should be satisfied that the employee has had appropriate training and is competent to do the job.

B.8.6 Continuing assessment

Even after training has been completed and authorization given, a periodic assessment of personnel should be carried out to determine continued competence. Refresher training should be carried out routinely every five years. It might be required earlier, for example, in the event of long periods of inactivity.

B.9 Selection and training of instructors

B.9.1 General

Training should be carried out by instructors who are competent, carefully selected and trained for the purpose.

B.9.2 Previous experience

As training contains a lot of practical work, instructors should have a minimum of two years of experience with HGLSs. In addition, instructors should hold a qualification in instructional techniques, and current certificates for HGLS operation, slinging and signalling.

B.9.3 Instructor training course content

Instructor training should cover the following topics:

- a) principles of instruction, including classroom techniques and practice demonstration techniques;
- b) the systems and processes used by the accrediting body;
- c) instruction on delivering the topics covered in **B.5** and **B.7.5**.

B.9.4 Assessment

Assessments should include:

- a) theoretical assessments of the instructor's knowledge relating to standards and legislation affecting HGLSs, technical aspects of HGLSs, operational requirements, training standards and instructional techniques;
- b) practical assessments covering the operation of an HGLS, preparing and presenting practical and classroom lessons, the administration of practical operator assessments, and producing assessment reports.

An instructor's competency should be reviewed annually and refresher training given, if needed.

Annex C (informative) **Background to the BS 7121 series**

The misuse of cranes through lack of knowledge and understanding of hazards and/or safe working procedures is a major cause of accidents. The BS 7121 series therefore aims to:

- a) describe the principal characteristics of the various forms of cranes of the types most commonly used;
- b) draw attention to some of the more common hazards and potential dangers which might be encountered in their use;
- c) recommend general precautions to be taken and procedures to be followed to avoid accidents;
- d) implement legislation by providing guidance drawn together by expert parties on good practice in the use of various types of cranes.

These codes of practice have been prepared by committees of representatives from different branches of the crane industry and the HSE. Their combined experience and specialist knowledge in the fields of crane design, manufacture, application and safety ensure that the recommendations are well founded and practical.

For over 28 years, UK experts have worked together codifying recommendations to address these issues that have been adopted and used by the crane industry.

It has long been recognized by the committees that the safe use of a crane ultimately rests with the operational personnel taking account of the manufacturer's/supplier's information.

Committee members are unanimous in their view that there is a need for the introduction of national systems, e.g. for licensing crane operators to operate only those types of cranes for which they have received training and have demonstrated their competence.

Management have the overall responsibility for safety and supervision and it is to management that these codes of practice are primarily directed.

The intention is that these codes are used by management both as a working guide and in the training of personnel in safe working practices, and that appropriate information and recommendations are incorporated in their company standing instructions for the safe use of cranes.

It is worth noting that the guidance published by the HSE in support of LOLER [1] makes eight references to the BS 7121 series.

The Health and Safety at Work etc. Act 1974 [5] requires duty holders to have in place safe systems for all work activities. The systems require adequate:

- 1) planning;
- 2) management and supervision;
- 3) training of personnel;
- 4) clear instructions.

The BS 7121 series has been accepted as representing the consensus of practical experience for safety on cranes. Therefore, as far as safe crane operations are concerned, the benchmark for safe working practices is the BS 7121 series.

Bibliography

British Standards

BS 4-1, *Structural steel sections – Part 1: Specification for hot-rolled sections*

BS 2573-1, *Rules for the design of cranes – Part 1: Specification for classification, stress calculations and design criteria for structures*

BS 5744, *Code of practice for safe use of cranes – (overhead/underhung travelling and goliath cranes, high pedestal and portal jib dockside cranes, manually-operated and light cranes, container handling cranes and rail-mounted low carriage cranes)*

BS 6399-2, *Loading for buildings – Part 2: Code of practice for wind loads*

BS 7262, *Specification for automatic safe load indicators*

BS EN 12077-2, *Cranes safety – Requirements for health and safety – Part 2: Limiting and indicating devices*

CP 3010, *Code of practice for safe use of cranes (mobile cranes, tower cranes and derrick cranes)*

Other publications

- [1] GREAT BRITAIN. The Lifting Operations and Lifting Equipment Regulations (LOLER) 1998. London: The Stationery Office.
- [2] GREAT BRITAIN. The Provision and Use of Work Equipment Regulations (PUWER) 1998. London: The Stationery Office.
- [3] HEALTH AND SAFETY EXECUTIVE. *Safe use of lifting equipment*. Approved Code of Practice and Guidance to LOLER. Sudbury: HSE Books, 1998.
- [4] HEALTH AND SAFETY EXECUTIVE. *Safe use of work equipment*. Approved Code of Practice and Guidance to PUWER. Sudbury: HSE Books, 2008.
- [5] GREAT BRITAIN. The Health and Safety at Work etc. Act 1974. London: The Stationery Office.
- [6] SPECIALIZED CARRIERS AND RIGGING ASSOCIATION (SC&RA). *Recommended Practices for Hydraulic Jacking Systems*. Fairfax, Virginia: SC&RA, 1996.
- [7] GREAT BRITAIN. The Management of Health and Safety at Work Act 1992. London: The Stationery Office.
- [8] HEALTH AND SAFETY EXECUTIVE. *Five steps to risk Assessment – A step by step guide to a safer and healthier workplace*. INDG163L. Sudbury: HSE Books, 2006.
- [9] GREAT BRITAIN. The Supply of Machinery Regulations 2008. London: The Stationery Office.
- [10] LIFTING EQUIPMENT ENGINEERS' ASSOCIATION. *Code of practice for the safe use of lifting equipment*. Huntingdon: Lifting Equipment Engineers' Association, 2009.

[11] EUROPEAN COMMUNITIES. Directive 2006/42/EC of the European Parliament and of the Council of 17 May 2006 on machinery, and amending Directive 95/16/EC (recast). Luxembourg: Office for Official Publications of the European Communities, 2006.¹⁾

¹⁾ Applicable from 29 December 2009.

British Standards Institution (BSI)

BSI is the independent national body responsible for preparing British Standards. It presents the UK view on standards in Europe and at the international level.

It is incorporated by Royal Charter.

Revisions

British Standards are updated by amendment or revision. Users of British Standards should make sure that they possess the latest amendments or editions.

It is the constant aim of BSI to improve the quality of our products and services. We would be grateful if anyone finding an inaccuracy or ambiguity while using this British Standard would inform the Secretary of the technical committee responsible, the identity of which can be found on the inside front cover.

Tel: +44 (0)20 8996 9000 Fax: +44 (0)20 8996 7400

BSI offers members an individual updating service called PLUS which ensures that subscribers automatically receive the latest editions of standards.

Buying standards

Orders for all BSI, international and foreign standards publications should be addressed to BSI Customer Services.

Tel: +44 (0)20 8996 9001 Fax: +44 (0)20 8996 7001
Email: orders@bsigroup.com

You may also buy directly using a debit/credit card from the BSI Shop on the website www.bsigroup.com/shop

In response to orders for international standards, it is BSI policy to supply the BSI implementation of those that have been published as British Standards, unless otherwise requested.

Information on standards

BSI provides a wide range of information on national, European and international standards through its Library.

Various BSI electronic information services are also available which give details on all its products and services. Contact the Information Centre.

Tel: +44 (0)20 8996 7111

Fax: +44 (0)20 8996 7048 Email: info@bsigroup.com

Subscribing members of BSI are kept up to date with standards developments and receive substantial discounts on the purchase price of standards. For details of these and other benefits contact Membership Administration.

Tel: +44 (0)20 8996 7002 Fax: +44 (0)20 8996 7001

Email: membership@bsigroup.com

Information regarding online access to British Standards via British Standards Online can be found at www.bsigroup.com/BSOL

Further information about BSI is available on the BSI website at www.bsigroup.com

Copyright

Copyright subsists in all BSI publications. BSI also holds the copyright, in the UK, of the publications of the international standardization bodies. Except as permitted under the Copyright, Designs and Patents Act 1988 no extract may be reproduced, stored in a retrieval system or transmitted in any form or by any means – electronic, photocopying, recording or otherwise – without prior written permission from BSI.

This does not preclude the free use, in the course of implementing the standard of necessary details such as symbols, and size, type or grade designations. If these details are to be used for any other purpose than implementation then the prior written permission of BSI must be obtained. Details and advice can be obtained from the Copyright & Licensing Manager.

Tel: +44 (0)20 8996 7070 Email: copyright@bsigroup.com

BSI Group Headquarters

389 Chiswick High Road London W4 4AL UK

Tel +44 (0)20 8996 9001

Fax +44 (0)20 8996 7001

www.bsigroup.com/standards

raising standards worldwide™

