

ASME B30.5-2018
(Revision of ASME B30.5-2014)

Mobile and Locomotive Cranes

**Safety Standard for Cableways,
Cranes, Derricks, Hoists, Hooks, Jacks,
and Slings**

AN AMERICAN NATIONAL STANDARD



ASME B30.5-2018
(Revision of ASME B30.5-2014)

Mobile and Locomotive Cranes

**Safety Standard for Cableways,
Cranes, Derricks, Hoists, Hooks, Jacks,
and Slings**

AN AMERICAN NATIONAL STANDARD



**The American Society of
Mechanical Engineers**

Two Park Avenue • New York, NY • 10016 USA

Date of Issuance: August 6, 2018

The next edition of this Standard is scheduled for publication in 2023. This Standard will become effective 1 year after the Date of Issuance.

ASME issues written replies to inquiries concerning interpretations of technical aspects of this Standard. Interpretations are published on the ASME website under the Committee Pages at <http://cstools.asme.org/> as they are issued.

Errata to codes and standards may be posted on the ASME website under the Committee Pages to provide corrections to incorrectly published items, or to correct typographical or grammatical errors in codes and standards. Such errata shall be used on the date posted.

The Committee Pages can be found at <http://cstools.asme.org/>. There is an option available to automatically receive an e-mail notification when errata are posted to a particular code or standard. This option can be found on the appropriate Committee Page after selecting "Errata" in the "Publication Information" section.

ASME is the registered trademark of The American Society of Mechanical Engineers.

This code or standard was developed under procedures accredited as meeting the criteria for American National Standards. The Standards Committee that approved the code or standard was balanced to assure that individuals from competent and concerned interests have had an opportunity to participate. The proposed code or standard was made available for public review and comment that provides an opportunity for additional public input from industry, academia, regulatory agencies, and the public-at-large.

ASME does not "approve," "rate," or "endorse" any item, construction, proprietary device, or activity.

ASME does not take any position with respect to the validity of any patent rights asserted in connection with any items mentioned in this document, and does not undertake to insure anyone utilizing a standard against liability for infringement of any applicable letters patent, nor assume any such liability. Users of a code or standard are expressly advised that determination of the validity of any such patent rights, and the risk of infringement of such rights, is entirely their own responsibility.

Participation by federal agency representative(s) or person(s) affiliated with industry is not to be interpreted as government or industry endorsement of this code or standard.

ASME accepts responsibility for only those interpretations of this document issued in accordance with the established ASME procedures and policies, which precludes the issuance of interpretations by individuals.

No part of this document may be reproduced in any form,
in an electronic retrieval system or otherwise,
without the prior written permission of the publisher.

The American Society of Mechanical Engineers
Two Park Avenue, New York, NY 10016-5990

Copyright © 2018 by
THE AMERICAN SOCIETY OF MECHANICAL ENGINEERS
All rights reserved
Printed in U.S.A.

CONTENTS

Foreword	v
Committee Roster	vi
B30 Standard Introduction	viii
Summary of Changes	xi
Chapter 5-0	
Scope, Definitions, Personnel Competence, and References	1
Section 5-0.1 Scope of B30.5	1
Section 5-0.2 Definitions	1
Section 5-0.3 Personnel Competence	6
Section 5-0.4 References	6
Chapter 5-1	
Construction and Characteristics	8
Section 5-1.1 Load Ratings and Technical Information	8
Section 5-1.2 Backward Stability	14
Section 5-1.3 Boom Hoist, Load Hoist, and Telescoping Boom Mechanisms	14
Section 5-1.4 Swing Mechanism	15
Section 5-1.5 Crane Travel	15
Section 5-1.6 Controls	16
Section 5-1.7 Ropes and Reeving Accessories	16
Section 5-1.8 Cabs	20
Section 5-1.9 General Requirements	21
Section 5-1.10 Structural Performance	22
Section 5-1.11 Cranes Used for Other Than Lifting Service	23
Section 5-1.12 Translations of Safety-Related Information and Control Designations	23
Chapter 5-2	
Inspection, Testing, and Maintenance	24
Section 5-2.1 Inspection — General	24
Section 5-2.2 Testing	25
Section 5-2.3 Maintenance	26
Section 5-2.4 Rope Inspection, Replacement, and Maintenance	27
Chapter 5-3	
Operation	30
Section 5-3.1 Qualifications and Responsibilities	30
Section 5-3.2 Operating Practices	34
Section 5-3.3 Signals	38
Section 5-3.4 Miscellaneous	41
Nonmandatory Appendix	
A Critical Lifts	49
Figures	
5-0.2.1-1 Commercial Truck-Mounted Crane — Telescoping Boom	2

5-0.2.1-2	Commercial Truck-Mounted Crane — Nontelescopng Boom	2
5-0.2.1-3	Crawler Crane	2
5-0.2.1-4	Crawler Crane — Telescoping Boom	2
5-0.2.1-5	Locomotive Crane	3
5-0.2.1-6	Wheel-Mounted Crane (Multiple Control Stations)	3
5-0.2.1-7	Wheel-Mounted Crane — Telescoping Boom (Multiple Control Stations)	4
5-0.2.1-8	Wheel-Mounted Crane (Single Control Station)	4
5-0.2.1-9	Wheel-Mounted Crane — Telescoping Boom (Single Control Station, Rotating)	5
5-0.2.1-10	Wheel-Mounted Crane — Telescoping Boom (Single Control Station, Fixed)	5
5-1.1.3-1	Work Areas	10
5-1.6.1-1	Telescopic Boom Crane Control Diagram (Suggested Mobile Telescopic Boom Crane Basic Operating Control Arrangement for New Cranes)	17
5-1.6.1-2	Nontelescopng Boom Crane Control Diagram (Suggested Mobile Nontelescopng Boom Crane Basic Operating Control Arrangement for New Cranes)	18
5-1.7.3-1	Dead Ending Rope in a Socket	20
5-2.4.2-1	Core Failure in 19 × 7 Rotation-Resistant Rope	27
5-3.2.1.5-1	Examples of Typical Unequal Outrigger Extension Positions	36
5-3.3.4-1	Standard Hand Signals for Controlling Crane Operations	39
5-3.4.5.1-1	Flowchart to Assist in Determination of the Applicable Subsection for Crane Operation Near Electric Power Lines	43
5-3.4.5.1-2	Specified Clearance Around an Energized Electric Power Line	44
5-3.4.5.1-3	Specified Clearance Around an Energized Electric Power Line That Shall Be Maintained When the Crane Is in Travel or Transit	45
5-3.4.5.1-4	Electric Power Line Support Structures	46
 Tables		
5-1.1.1-1	Crane Load Ratings	9
5-3.4.5.1-1	Specified Clearance in the Vicinity of Energized Electric Power Lines	45

FOREWORD

This American National Standard, Safety Standard for Cableways, Cranes, Derricks, Hoists, Hooks, Jacks, and Slings, has been developed under the procedures accredited by the American National Standards Institute (ANSI). This Standard had its beginning in December 1916 when an eight-page Code of Safety Standards for Cranes, prepared by the ASME Committee on the Protection of Industrial Workers, was presented at the annual meeting of ASME.

Meetings and discussions regarding safety on cranes, derricks, and hoists were held from 1920 to 1925, involving the ASME Safety Code Correlating Committee, the Association of Iron and Steel Electrical Engineers, the American Museum of Safety, the American Engineering Standards Committee (AESC) [later changed to the American Standards Association (ASA), then to the United States of America Standards Institute (USASI), and finally to ANSI], Department of Labor — State of New Jersey, Department of Labor and Industry — State of Pennsylvania, and the Locomotive Crane Manufacturers Association. On June 11, 1925, AESC approved the ASME Safety Code Correlating Committee's recommendation and authorized the project with the U.S. Department of the Navy, Bureau of Yards and Docks, and ASME as sponsors.

In March 1926, invitations were issued to 50 organizations to appoint representatives to a Sectional Committee. The call for organization of this Sectional Committee was sent out October 2, 1926, and the committee organized November 4, 1926, with 57 members representing 29 national organizations. Commencing June 1, 1927, and using the eight-page code published by ASME in 1916 as a basis, the Sectional Committee developed the "Safety Code for Cranes, Derricks, and Hoists." The early drafts of this safety code included requirements for jacks but, due to inputs and comments on those drafts, the Sectional Committee decided in 1938 to make the requirements for jacks a separate code. In January 1943, ASA B30.2-1943 was published addressing a multitude of equipment types and in August 1943, ASA B30.1-1943 was published addressing just jacks. Both documents were reaffirmed in 1952 and widely accepted as safety standards.

Due to changes in design, advancement in techniques, and general interest of labor and industry in safety, the Sectional Committee, under the joint sponsorship of ASME and the Bureau of Yards and Docks (now the Naval Facilities Engineering Command), was reorganized on January 31, 1962, with 39 members representing 27 national organizations. The new committee changed the format of ASA B30.2-1943 so that the multitude of equipment types it addressed could be published in separate volumes that could completely cover the construction, installation, inspection, testing, maintenance, and operation of each type of equipment that was included in the scope of ASA B30.2. This format change resulted in the initial publication of B30.3, B30.5, B30.6, B30.11, and B30.16 being designated as "Revisions" of B30.2 with the remainder of the B30 volumes being published as totally new volumes. ASA changed its name to USASI in 1966 and to ANSI in 1969, which resulted in B30 volumes from 1943 to 1968 being designated as "ASA B30," "USAS B30" or "ANSI B30" depending on their date of publication.

In 1982, the committee was reorganized as an Accredited Organization Committee, operating under procedures developed by ASME and accredited by ANSI. This Standard presents a coordinated set of rules that may serve as a guide to government and other regulatory bodies and municipal authorities responsible for the guarding and inspection of the equipment falling within its scope. The suggestions leading to accident prevention are given as both mandatory and advisory provisions; compliance with both types may be required by employers of their employees.

In case of practical difficulties, new developments, or unnecessary hardship, the administrative or regulatory authority may grant variances from the literal requirements or permit the use of other devices or methods, but only when it is clearly evident that an equivalent degree of protection is thereby secured. To secure uniform application and interpretation of this Standard, administrative or regulatory authorities are urged to consult the B30 Committee in accordance with the format described in [Section IX](#) of the B30 Standard Introduction, before rendering decisions on disputed points.

Safety codes and standards are intended to enhance public safety. Revisions result from committee consideration of factors such as technological advances, new data, and changing environmental and industry needs. Revisions do not imply that previous editions were inadequate.

The ASME B30.5-2007 edition added responsibilities to be assigned in the worksite organization. The 2011 edition included minor revisions and the addition of [Nonmandatory Appendix A](#) on critical lifts. The 2014 edition incorporated many global B30 changes including the addition of personnel competence and translation requirements as well as other revisions made throughout the document. This 2018 edition revises the Crane Operation in the Vicinity of Electric Power Lines section entirely, adds a new section on Rigger Responsibilities, and incorporates other miscellaneous revisions.

This edition of the B30.5 Volume was approved by the B30 Committee and by ASME, and was approved by ANSI and designated as an American National Standard on June 12, 2018.

ASME B30 COMMITTEE

Safety Standard for Cableways, Cranes, Derricks, Hoists, Hooks, Jacks, and Slings

(The following is the roster of the Committee at the time of approval of this Standard.)

STANDARDS COMMITTEE OFFICERS

T. L. Blanton, *Chair*
E. D. Fidler, *Vice Chair*
K. M. Hyam, *Secretary*

STANDARDS COMMITTEE PERSONNEL

N. E. Andrew, LTS Crane Mechanical
T. L. Blanton, NACB Group, Inc.
P. A. Boeckman, The Cosby Group, Inc.
P. W. Boyd, The Boeing Co.
B. D. Closson, Craft Forensic Services
J. A. Danielson, The Boeing Co.
D. R. Decker, Becket, LLC
L. D. Demark, Sr., Equipment Training Solutions, LLC
D. W. Eckstine, Eckstine & Associates
R. J. Edwards, NationsBuilders Insurance Services, Inc.
A. J. Egging, National Oilwell Varco
E. D. Fidler, Grove U.S., LLC
J. A. Gilbert, Associated Wire Rope Fabricators
J. L. Gordon, Acco Material Handling Solutions, Inc.
N. C. Hargreaves, Terex Hargreaves Consulting, LLC
G. B. Hetherston, Consultant
K. M. Hyam, The American Society of Mechanical Engineers
M. M. Jaxtheimer, Navy Crane Center
P. R. Juhren, Morrow Equipment Co., LLC
R. M. Kohner, Landmark Engineering Services
A. J. Lusi, Jr., Lumark Consulting LLP
E. K. Marburg, Columbus McKinnon Corp.
L. D. Means, Means Engineering & Consulting
M. W. Mills, Liberty Mutual Insurance
D. L. Morgan, Critical Lift Consultants, LLC
W. E. Osborn, Ingersoll Rand
R. M. Parnell, ITI-Field Service
J. T. Perkins, First Solar Electric
B. A. Pickett, Systems Engineering and Forensic Services
J. A. Pilgrim, Manitowoc Cranes
S. K. Rammelsberg, CB&I
J. E. Richardson, U.S. Department of the Navy
D. W. Ritchie, Dave Ritchie Consultant, LLC
J. W. Rowland III, Consultant
J. C. Ryan, Boh Bros. Construction Co.
D. W. Smith, STI Group
W. J. Smith, Jr., NationsBuilders Insurance Services, Inc.
R. S. Stemp, Lampson International, LLC
R. G. Strain, Advanced Crane Technologies, LLC
J. Sturm, Sturm Corp.
P. D. Sweeney, Riverside Engineering, LLC
E. P. Vliet, Consultant
J. D. Wiethorn, Haag Engineering Co.
R. C. Wild, CJ Drilling, Inc.
D. N. Wolff, National Crane/Manitowoc Crane Group
S. D. Wood, Terex Corp.
B. B. Bacon, *Alternate*, Tennessee Valley Authority
R. J. Bolen, *Alternate*, Consultant
G. J. Brent, *Alternate*, NCCCO
J. R. Burkey, *Alternate*, Columbus McKinnon Corp.
B. M. Casey, *Alternate*, Electric Boat
W. C. Dickinson, Jr., *Alternate*, Crane Industry Services, LLC
J. Dudley, *Alternate*, The Walsh Group
D. Duerr, *Alternate*, 2DM Associates, Inc.
M. Eggenberger, *Alternate*, Berry Contracting, Inc.
S. R. Fletcher, *Alternate*, Cowles, Murphy, Glover & Associates
M. Gardiner, *Alternate*, Haag Engineering Co.
S. R. Gridley, *Alternate*, Navy Crane Center
D. A. Henninger, *Alternate*, Bridon Bekaert, The Ropes Group
D. F. Jordan, *Alternate*, American International Crane Bureau
K. Kennedy, *Alternate*, Navy Crane Center
J. Lindsay, *Alternate*, Link-Belt Construction Equipment
E. E. Lutter, *Alternate*, Gunnebo Johnson Corp.
T. C. Mackey, *Alternate*, Washington River Protection Solutions
J. P. Mihilbauer, *Alternate*, All Ship & Cargo Surveys, Ltd.
D. A. Moore, *Alternate*, Unified Engineering
L. S. Olver, *Alternate*, Kolo Holdings, Inc.
J. M. Randall, *Alternate*, CB&I
K. Rask, *Alternate*, NationsBuilders Insurance Services, Inc.
C. L. Richardson, *Alternate*, Lone Star Rigging, LP
A. R. Ruud, *Alternate*, Atkinson Construction
J. R. Schober, *Alternate*, American Bridge Co.
J. Schoppert, *Alternate*, NBIS Claims & Risk Management
L. K. Shapiro, *Alternate*, Howard I. Shapiro & Associates
K. Shinn, *Alternate*, K. J. Shinn, Inc.
C. H. Smith, *Alternate*, Morrow Equipment Co., LLC
S. Snider, *Alternate*, Ingersoll Rand
R. Stanoch, *Alternate*, IPS Cranes
C. Warren, *Alternate*, Webber, LLC
A. T. West, *Alternate*, Liberty Mutual Insurance
M. P. Zerba, *Alternate*, Lampson International, LLC
J. W. Downs, Jr., *Honorary Member*, Downs Crane and Hoist Co.
J. L. Franks, *Honorary Member*, Consultant
C. W. Ireland, *Honorary Member*, National Oilwell Varco
J. M. Klibert, *Honorary Member*, Lift-All Co., Inc.
R. W. Parry, *Honorary Member*, Consultant

B30.5 SUBCOMMITTEE PERSONNEL

S. D. Wood, *Chair*, Terex Corp.
K. Adolf, Local 825 Apprenticeship Training and Retraining
R. J. Bolen, Consultant
A. L. Calta, Elliott Equipment Co.
D. W. Eckstine, Eckstine & Associates
M. Gardiner, Haag Engineering Co.
D. A. Henninger, Bridon-Bekaert, The Ropes Group
D. F. Jordan, American International Crane Bureau
R. M. Kohner, Landmark Engineering Services
J. Lindsay, Link-Belt Construction Equipment
J. A. Pilgrim, Manitowoc Cranes
J. C. Ryan, Boh Bros. Construction Co.
T. Sicklesteel, Sicklesteel Cranes, Inc.
J. Sturm, Sturm Corp.
J. J. Van Egeren, Manitowoc Cranes
R. C. Wild, CJ Drilling, Inc.

L. D. Demark, Sr., *Alternate*, Equipment Training Solutions, LLC
E. D. Fidler, *Alternate*, Grove U.S., LLC
G. B. Hetherston, *Alternate*, Consultant
A. J. Lusi, Jr., *Alternate*, Lumark Consulting, LLP
L. D. Means, *Alternate*, Means Engineering & Consulting
D. L. Morgan, *Alternate*, Critical Lift Consultants, LLC
T. C. Radenslaben, Jr., *Alternate*, Elliott Equipment Co.
D. W. Ritchie, *Alternate*, Dave Ritchie Consultant, LLC
A. R. Ruud, *Alternate*, Atkinson Construction
J. R. Schober, *Alternate*, American Bridge Co.
J. Schoppert, *Alternate*, NBIS Claims & Risk Management
E. J. Slocombe, *Alternate*, Broderson Manufacturing Corp.
W. J. Smith, Jr., *Alternate*, NationsBuilders Insurance Services, Inc.
R. S. Stemp, *Alternate*, Lampson International, LLC
E. P. Vliet, *Alternate*, Consultant

B30 INTEREST REVIEW GROUP

O. Akinbooye, Ropetech Engineering Services
D. Beltran, Gunnebo Johnson Corp.
J. D. Cannon, U.S. Army Corps of Engineers
B. Dobbs, LEEA
M. J. Eggenberger, Berry Contracting, Inc.
A. Gomes Rocha, Belgo Bekaert Arames
H. A. Hashem, Saudi Aramco
J. Hui, Si Pai Lou, School of Civil Engineering

C. Lan, Department of Industry — Bureau of Safety and Environmental Enforcement
A. C. Mattoli, Prowinch, LLC
J. P. Mihlbauer, All Ship & Cargo Surveys, Ltd.
L. S. Olver, Kolo Holdings, Inc.
G. L. Owens, Consultant
D. R. Remus, Reed Manufacturing
C. C. Tsauro, Institute of Occupational Safety and Health

B30 REGULATORY AUTHORITY COUNCIL

C. Shelhamer, *Chair*, New York City Department of Buildings
K. M. Hyam, *Secretary*, The American Society of Mechanical Engineers
L. G. Campion, U.S. Department of Labor/OSHA
R. Feidt, Stephenson Equipment, Inc.
C. Harris, City of Chicago — Department of Buildings
R. D. Jackson, U.S. Department of Labor
J. L. Lankford, State of Nevada (OSHA)
D. E. Latham, State of Maryland (DLLR)
A. Lundeen, Washington State Department of Labor and Industries

J. Mendoza, North Carolina Department of Labor, Occupational Safety and Health
M. J. Nelmida, State of California, Occupational Safety and Health Standards Board (OSHSB)
G. E. Pushies, MIOSHA
C. N. Stribling, Jr., Kentucky Labor Cabinet
T. Taylor, Minnesota Department of Labor and Industry
A. O. Omran, *Alternate*, New York City Department of Buildings
K. L. Powell, *Alternate*, Maryland Department of Labor, MOSH

B30 STANDARD INTRODUCTION

SECTION I: SCOPE

The ASME B30 Standard contains provisions that apply to the construction, installation, operation, inspection, testing, maintenance, and use of cranes and other lifting and material-movement-related equipment. For the convenience of the reader, the Standard has been divided into separate volumes. Each volume has been written under the direction of the ASME B30 Standards Committee and has successfully completed a consensus approval process under the general auspices of the American National Standards Institute (ANSI).

As of the date of issuance of this Volume, the B30 Standard comprises the following volumes:

- B30.1 Jacks, Industrial Rollers, Air Casters, and Hydraulic Gantries
- B30.2 Overhead and Gantry Cranes (Top Running Bridge, Single or Multiple Girder, Top Running Trolley Hoist)
- B30.3 Tower Cranes
- B30.4 Portal and Pedestal Cranes
- B30.5 Mobile and Locomotive Cranes
- B30.6 Derricks
- B30.7 Winches
- B30.8 Floating Cranes and Floating Derricks
- B30.9 Slings
- B30.10 Hooks
- B30.11 Monorails and Underhung Cranes (withdrawn 2018 — requirements found in latest revision of B30.17)
- B30.12 Handling Loads Suspended From Rotorcraft
- B30.13 Storage/Retrieval (S/R) Machines and Associated Equipment
- B30.14 Side Boom Tractors
- B30.15 Mobile Hydraulic Cranes (withdrawn 1982 — requirements found in latest revision of B30.5)
- B30.16 Overhead Underhung and Stationary Hoists
- B30.17 Cranes and Monorails (With Underhung Trolley or Bridge)
- B30.18 Stacker Cranes (Top or Under Running Bridge, Multiple Girder With Top or Under Running Trolley Hoist)
- B30.19 Cableways

- B30.20 Below-the-Hook Lifting Devices
- B30.21 Lever Hoists
- B30.22 Articulating Boom Cranes
- B30.23 Personnel Lifting Systems
- B30.24 Container Cranes
- B30.25 Scrap and Material Handlers
- B30.26 Rigging Hardware
- B30.27 Material Placement Systems
- B30.28 Balance Lifting Units
- B30.29 Self-Erecting Tower Cranes
- B30.30 Ropes¹
- B30.31 Self-Propelled, Towed, or Remote-Controlled Hydraulic Platform Transporters¹
- B30.32 Unmanned Aircraft Systems (UAS) Used in Inspection, Testing, Maintenance, and Lifting Operations¹

SECTION II: SCOPE EXCLUSIONS

Any exclusion of, or limitations applicable to, the equipment, requirements, recommendations, or operations contained in this Standard are established in the affected volume's scope.

SECTION III: PURPOSE

The B30 Standard is intended to

- (a) prevent or minimize injury to workers, and otherwise provide for the protection of life, limb, and property by prescribing safety requirements
- (b) provide direction to manufacturers, owners, employers, users, and others concerned with, or responsible for, its application
- (c) guide governments and other regulatory bodies in the development, promulgation, and enforcement of appropriate safety directives

SECTION IV: USE BY REGULATORY AGENCIES

These volumes may be adopted in whole or in part for governmental or regulatory use. If adopted for governmental use, the references to other national codes and standards in the specific volumes may be changed to refer to the corresponding regulations of the governmental authorities.

¹This volume is currently in the development process.

SECTION V: EFFECTIVE DATE

(a) *Effective Date.* The effective date of this Volume of the B30 Standard shall be 1 yr after its date of issuance. Construction, installation, inspection, testing, maintenance, and operation of equipment manufactured and facilities constructed after the effective date of this Volume shall conform to the mandatory requirements of this Volume.

(b) *Existing Installations.* Equipment manufactured and facilities constructed prior to the effective date of this Volume of the B30 Standard shall be subject to the inspection, testing, maintenance, and operation requirements of this Standard after the effective date.

It is not the intent of this Volume of the B30 Standard to require retrofitting of existing equipment. However, when an item is being modified, its performance requirements shall be reviewed relative to the requirements within the current volume. The need to meet the current requirements shall be evaluated by a qualified person selected by the owner (user). Recommended changes shall be made by the owner (user) within 1 yr.

SECTION VI: REQUIREMENTS AND RECOMMENDATIONS

Requirements of this Standard are characterized by use of the word *shall*. Recommendations of this Standard are characterized by the word *should*.

SECTION VII: USE OF MEASUREMENT UNITS

This Standard contains SI (metric) units as well as U.S. Customary units. The values stated in U.S. Customary units are to be regarded as the standard. The SI units are a direct (soft) conversion from the U.S. Customary units.

SECTION VIII: REQUESTS FOR REVISION

The B30 Standards Committee will consider requests for revision of any of the volumes within the B30 Standard. Such requests should be directed to

Secretary, B30 Standards Committee
ASME Codes and Standards
Two Park Avenue
New York, NY 10016-5990

Requests should be in the following format:

Volume: Cite the designation and title of the volume.
Edition: Cite the applicable edition of the volume.
Subject: Cite the applicable paragraph number(s) and the relevant heading(s).
Request: Indicate the suggested revision.
Rationale: State the rationale for the suggested revision.

Upon receipt by the Secretary, the request will be forwarded to the relevant B30 Subcommittee for consideration and action. Correspondence will be provided to the requester defining the actions undertaken by the B30 Standards Committee.

SECTION IX: REQUESTS FOR INTERPRETATION

The B30 Standards Committee will render an interpretation of the provisions of the B30 Standard. An Interpretation Submittal Form is available on ASME's website at <http://cstools.asme.org/Interpretation/InterpretationForm.cfm>.

Phrase the question as a request for an interpretation of a specific provision suitable for general understanding and use, not as a request for approval of a proprietary design or situation. Plans or drawings that explain the question may be submitted to clarify the question. However, they should not contain any proprietary names or information. Read carefully the note addressing the types of requests that the B30 Standards Committee can and cannot consider.

Upon submittal, the request will be forwarded to the relevant B30 Subcommittee for a draft response, which will then be subject to approval by the B30 Standards Committee prior to its formal issuance. The B30 Standards Committee may rewrite the question for the sake of clarity.

Interpretations to the B30 Standard will be available online at <https://cstools.asme.org/Interpretation/SearchInterpretation.cfm>.

SECTION X: ADDITIONAL GUIDANCE

The equipment covered by the B30 Standard is subject to hazards that cannot be abated by mechanical means, but only by the exercise of intelligence, care, and common sense. It is therefore essential to have personnel involved in the use and operation of equipment who are competent, careful, physically and mentally qualified, and trained in the proper operation of the equipment and the handling of loads. Serious hazards include, but are not limited to, improper or inadequate maintenance, overloading, dropping or slipping of the load, obstructing the free passage of the load, and using equipment for a purpose for which it was not intended or designed.

The B30 Standards Committee fully realizes the importance of proper design factors, minimum or maximum dimensions, and other limiting criteria of wire rope or chain and their fastenings, sheaves, sprockets, drums, and similar equipment covered by the Standard, all of which are closely connected with safety. Sizes, strengths, and similar criteria are dependent on many different factors, often varying with the installation and uses. These factors depend on

- (a) the condition of the equipment or material
- (b) the loads

(c) the acceleration or speed of the ropes, chains, sheaves, sprockets, or drums

(d) the type of attachments

(e) the number, size, and arrangement of sheaves or other parts

(f) environmental conditions causing corrosion or wear

(g) many variables that must be considered in each individual case

The requirements and recommendations provided in the volumes must be interpreted accordingly, and judgment used in determining their application.

ASME B30.5-2018 SUMMARY OF CHANGES

Following approval by the ASME B30 Committee and ASME, and after public review, ASME B30.5-2018 was approved by the American National Standards Institute on June 12, 2018.

ASME B30.5-2018 includes the following changes identified by a margin note, **(18)**.

<i>Page</i>	<i>Location</i>	<i>Change</i>
1	B30 Standard Introduction 5-0.2.2	Sections I and IX revised (1) Definitions of <i>accessory, anti-two-block device, auxiliary hoist, axle, ballast, boom angle indicator, boom stop, brake, cab, counterweight, crossover points, drum, flange point, jobsite, load hoist, load ratings, lower load block, mounting base, normal operating conditions, operational aid, outriggers, pawl (dog), payload, pendant, reeving, rotation-resistant wire rope, shall, should, side loading, standby crane, standing rope, structural competence, superstructure, tackle, telescoping boom, transit, travel, two-block damage prevention feature, upper load block, whip line (auxiliary), and working load</i> revised (2) Definitions of <i>administrative or regulatory authority, axle (bogie), dynamic (loading), ensure, jib backstop, load indicator, qualified operator, swiveling,</i> and <i>wheel base</i> deleted (3) Definitions of <i>backward stability, crane configuration, dedicated spotter, forward stability, maximum horizontal reach, radius,</i> and <i>rated capacity</i> added
6	5-0.4	(1) Address of ASME and name of SAE International updated (2) ASTM A1023/A1023M, ISO 7000, and ISO 7296 added
9	5-1.1.3	Subparagraph (b)(12) added
9	5-1.1.4	Subparagraph (a)(4) added and subsequent subparagraphs redesignated
13	Figure 5-1.1.3-1	Subcaption under part (a) revised
14	5-1.2	(1) Title revised (2) Paragraph 5-1.2.1 deleted and subsequent paragraphs redesignated

		(3) In redesignated para. 5-1.2.2, title, first paragraph, and cross references in subpara. (d) revised
		(4) Paragraph 5-1.2.4 deleted
14	5-1.3.2	Subparagraph (a)(2)(-c) revised
20	5-1.8.1	(1) Subparagraph (b) and redesignated subpara. (f) revised
		(2) Subparagraph (c) added and subsequent subparagraphs redesignated
24	5-2.1	Last sentence revised
24	5-2.1.1	Subparagraphs (a) and (b)(1) revised
24	5-2.1.2	First paragraph revised
24	5-2.1.3	First paragraph revised
25	5-2.1.4	Revised
25	5-2.1.5	Subparagraph (a) revised
25	5-2.1.6	Subparagraph (b) revised
27	5-2.4.1	First subparagraph redesignated as (a) and subpara. (b) added
27	5-2.4.2	Subparagraph (b)(2) revised
28	5-2.4.3	Subparagraph (h) revised
31	5-3.1.3	Subparagraph (f) added
32	5-3.1.3.1.2	Subparagraphs (g) and (h) revised
32	5-3.1.3.2.1	Subparagraph (k) revised
33	5-3.1.3.2.2	(1) Subparagraph (n) revised
		(2) Subparagraph (o) deleted
33	5-3.1.3.3.1	(1) Subparagraph (q) added and subsequent subparagraphs redesignated
		(2) Redesignated subpara. (w) revised
34	5-3.1.3.4	Added
41	Figure 5-3.3.4-1	Editorially revised
41	5-3.4.5	Revised in its entirety
49	Nonmandatory Appendix A, A-1	Subparagraph (g) revised

Chapter 5-0

Scope, Definitions, Personnel Competence, and References

SECTION 5-0.1: SCOPE OF B30.5

Within the general scope defined in [Section I](#) of the B30 Standard Introduction, American National Standard B30.5 applies to crawler cranes, locomotive cranes, wheel-mounted cranes, and any variations thereof that retain the same fundamental characteristics. The scope includes only cranes of the above types that are basically powered by internal combustion engines or electric motors. Side boom tractors and cranes designed for railway and automobile wreck clearance, digger derricks, cranes manufactured specifically for, or when used for, energized electrical line service, knuckle boom, trolley boom cranes, and cranes having a maximum rated capacity of 1 ton or less are excluded.

Special adaptations to the general types of machines covered by this Volume, where applicable, fall under this scope.

Some basic machine types within this scope are used alternatively for lifting service and for applications not considered to be lifting service. All of the requirements of this Volume are applicable to such machines when used for lifting service. However, at a minimum, [Section 5-1.11](#), [Chapter 5-2](#), and [Section 5-3.1](#) of this Volume apply to machines when used in other than lifting service.

SECTION 5-0.2: DEFINITIONS

5-0.2.1 Types of Mobile and Locomotive Cranes

commercial truck-mounted crane: a crane consisting of a rotating superstructure (center post or turntable), boom, operating machinery, and one or more operator's stations mounted on a frame attached to a commercial truck chassis, usually retaining a payload hauling capability whose power source usually powers the crane. Its function is to lift, lower, and swing loads at various radii (see [Figures 5-0.2.1-1](#) and [5-0.2.1-2](#)).

crawler crane: a crane consisting of a rotating superstructure with a power plant, operating machinery, and boom, mounted on a base and equipped with crawler treads for travel. Its function is to lift, lower, and swing loads at various radii (see [Figures 5-0.2.1-3](#) and [5-0.2.1-4](#)).

locomotive crane: a crane consisting of a rotating superstructure with a power plant, operating machinery, and boom, mounted on a base or car equipped for travel on a

railroad track. It may be self-propelled or propelled by an outside source. Its function is to lift, lower, and swing loads at various radii (see [Figure 5-0.2.1-5](#)).

wheel-mounted crane (multiple control stations): a crane consisting of a rotating superstructure, operating machinery, and operator's station and boom, mounted on a crane carrier equipped with axles and rubber-tired wheels for travel, a power source(s), and having separate stations for driving and operating. Its function is to lift, lower, and swing loads at various radii (see [Figures 5-0.2.1-6](#) and [5-0.2.1-7](#)).

wheel-mounted crane (single control station): a crane consisting of a rotating superstructure, operating machinery, and boom, mounted on a crane carrier equipped with axles and rubber-tired wheels for travel, a power source, and having a single control station for driving and operating. Its function is to lift, lower, and swing loads at various radii (see [Figures 5-0.2.1-8](#) through [5-0.2.1-10](#)).

5-0.2.2 General

(18)

accessory: a secondary part or assembly of parts that contributes to the overall function and usefulness of the equipment.

anti-two-block device: a device that, when activated, disengages all equipment functions whose movement can cause two-blocking.

auxiliary hoist: a secondary mechanism used either in conjunction with, or independently of, the main hoist.

axis of rotation: the vertical axis around which the crane superstructure rotates.

axle: the shaft or spindle with which or about which a wheel rotates. It refers to a type of axle assembly including housings, gearing, differential, bearings, and mounting appurtenances.

backward stability: the ability of a crane to resist overturning in the direction opposite the boom while in a loaded or unloaded condition.

ballast: weight used to supplement the weight of the machine in providing stability for lifting loads (the term *ballast* is normally associated with locomotive cranes).

Figure 5-0.2.1-1 Commercial Truck-Mounted Crane — Telescoping Boom

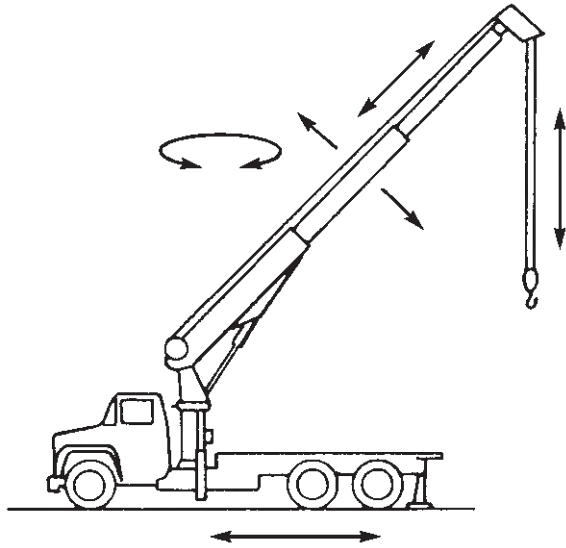

GENERAL NOTE: The boom may have a base boom structure of sections (upper and lower) between or beyond which additional sections may be added to increase its length, or it may consist of a base boom from which one or more boom extensions are telescoped for additional length.

Figure 5-0.2.1-2 Commercial Truck-Mounted Crane — Nontelelescoping Boom

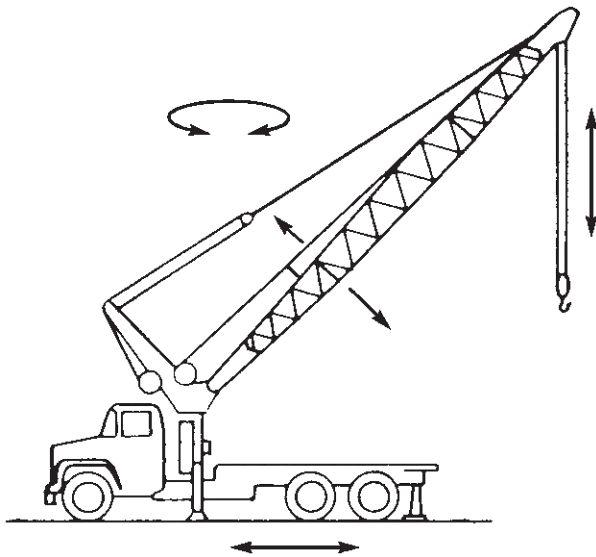

GENERAL NOTE: The boom may have a base boom structure of sections (upper and lower) between or beyond which additional sections may be added to increase its length, or it may consist of a base boom from which one or more boom extensions are telescoped for additional length.

Figure 5-0.2.1-3 Crawler Crane

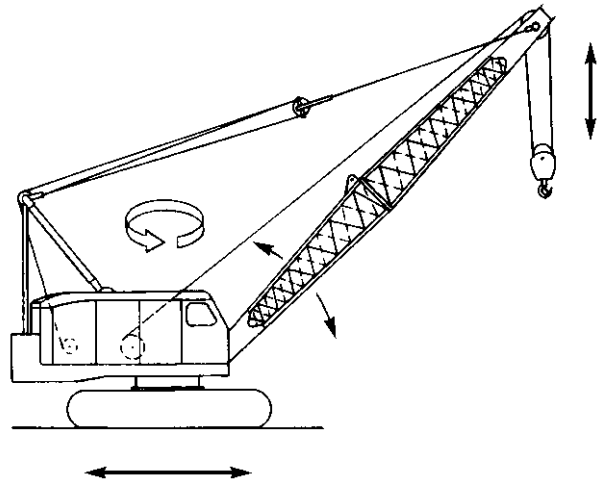
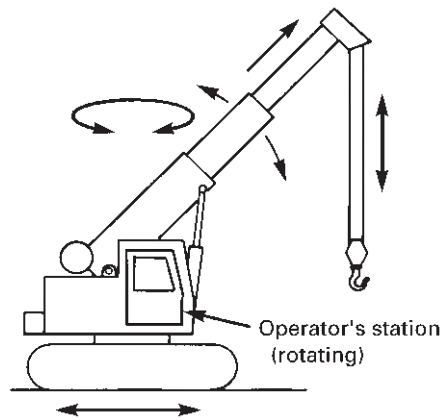

Figure 5-0.2.1-4 Crawler Crane — Telescoping Boom



GENERAL NOTE: The boom may have a base boom structure of sections (upper and lower) between or beyond which additional sections may be added to increase its length, or it may consist of a base boom from which one or more boom extensions are telescoped for additional length.

boom (crane): a member hinged to the rotating superstructure and used for supporting the hoisting tackle.

boom angle: the angle above or below horizontal of the longitudinal axis of the base boom section.

boom angle indicator: an accessory that measures the angle of the boom to the horizontal.

boom hoist mechanism: means for supporting the boom and controlling the boom angle.

boom point: the outer extremity of the crane boom, containing the hoist sheave assembly.

boom point sheave assembly: an assembly of sheaves and pin built as an integral part of the boom point.

Figure 5-0.2.1-5 Locomotive Crane

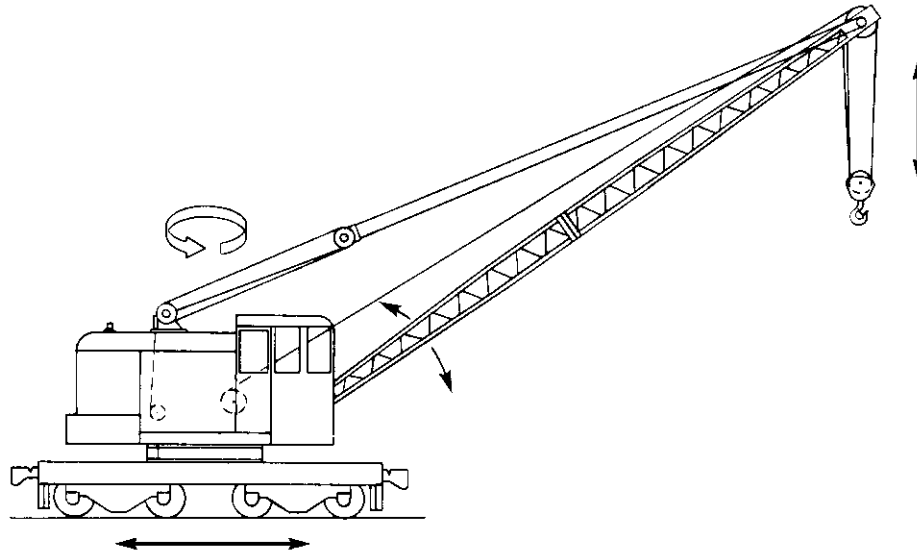
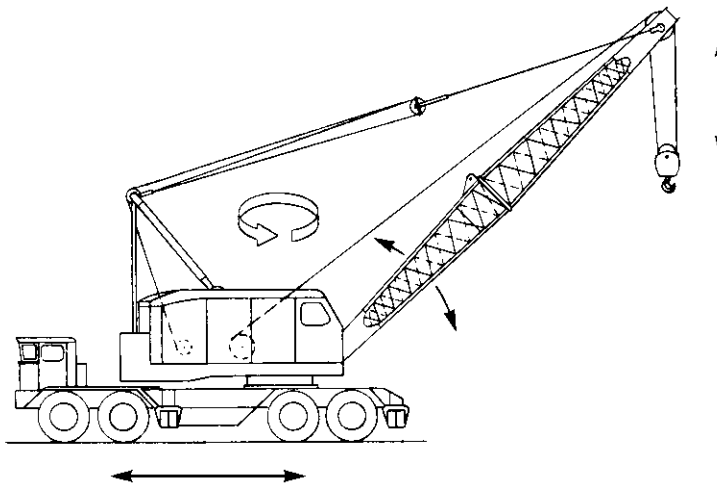

Figure 5-0.2.1-6 Wheel-Mounted Crane (Multiple Control Stations)



boom stop: a device or structure designed to limit boom travel to its highest allowable position.

brake: a device, other than a motor, used for retarding or stopping motion by means of friction or power.

cab: the operator's compartment or the driver's compartment on the equipment.

clutch: a means for engagement or disengagement of power.

commercial truck vehicle: a commercial motor vehicle designed primarily for the transportation of property in connection with business and industry.

counterweight: weight used to supplement the weight of the equipment in providing stability for lifting loads.

crane carrier: the undercarriage of a wheel-mounted crane specifically designed for transporting the rotating crane superstructure. It may or may not provide its own travel mechanism. It is distinguished from a commercial truck vehicle in that it is not designed to transport personnel, materials, or equipment other than the crane-rotating superstructure.

crane configuration: the postassembly arrangement of the crane including boom, supporting base, counterweight(s), jib(s), extension(s), and attachment(s).

critical lift: a hoisting or lifting operation that has been determined to present an increased level of risk beyond normal lifting activities. For example, increased risk may relate to personnel injury, damage to property,

Figure 5-0.2.1-7 Wheel-Mounted Crane — Telescoping Boom (Multiple Control Stations)

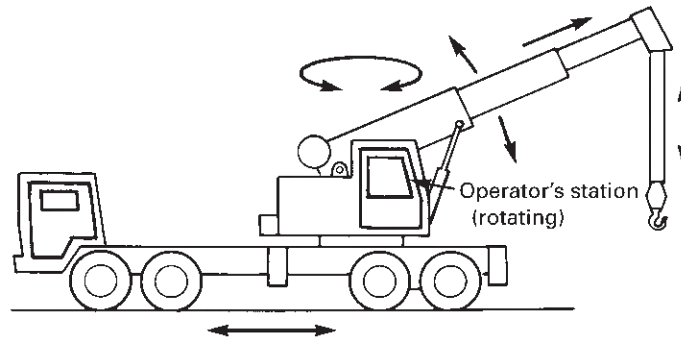

GENERAL NOTE: The boom may have a base boom structure of sections (upper and lower) between or beyond which additional sections may be added to increase its length, or it may consist of a base boom from which one or more boom extensions are telescoped for additional length.

Figure 5-0.2.1-8 Wheel-Mounted Crane (Single Control Station)

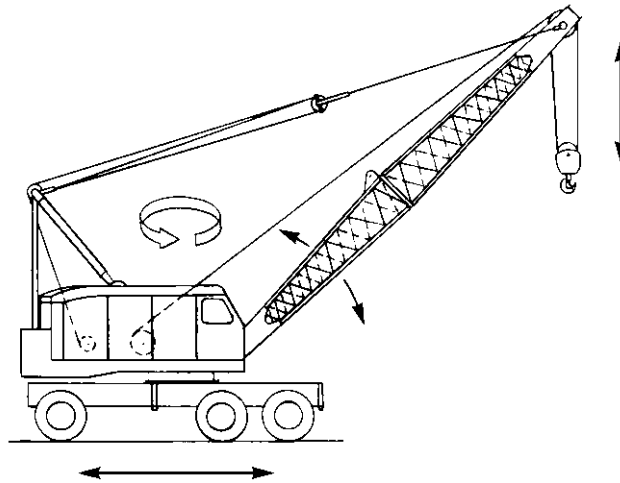

interruption of plant production, delays in schedule, release of hazards to the environment, or other jobsite factors.

crossover points: in multiple layer spooling of rope on a drum, those points of rope contact where the rope crosses the preceding rope layer.

dedicated spotter: a qualified person who is in continuous contact with the operator and whose sole responsibility is to verify that the specified clearance is maintained.

drum: a cylindrical member around which the rope is wound for lifting and lowering the load or boom.

flange point: the point of contact between the rope and the drum flange where the rope changes layers.

forward stability: the ability of a crane to resist overturning in the direction of the boom point while in a loaded or unloaded condition.

gantry (A-frame): a structural frame, extending above the superstructure, to which the boom support ropes are reeved.

jib: an extension attached to the boom point to provide added boom length for lifting specified loads. The jib may be in line with the boom or offset to various angles in the vertical plane of the boom.

jobsite: area within the boundaries of the project where the equipment is to be operated.

load hoist: a hoist drum and rope reeving system used for lifting and lowering loads.

load ratings: ratings in pounds (kilograms) established by the manufacturer.

lower load block: the assembly of hook or shackle, swivel, sheaves, pins, and frame suspended by the hoisting rope.

luffing attachment: a front end attachment for a mobile crane that uses an upper working boom or jib, which is capable of changing angle during operation and is

Figure 5-0.2.1-9 Wheel-Mounted Crane — Telescoping Boom (Single Control Station, Rotating)

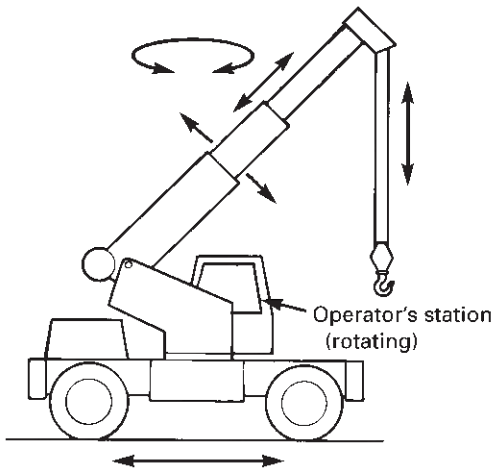

GENERAL NOTE: The boom may have a base boom structure of sections (upper and lower) between or beyond which additional sections may be added to increase its length, or it may consist of a base boom from which one or more boom extensions are telescoped for additional length.

Figure 5-0.2.1-10 Wheel-Mounted Crane — Telescoping Boom (Single Control Station, Fixed)

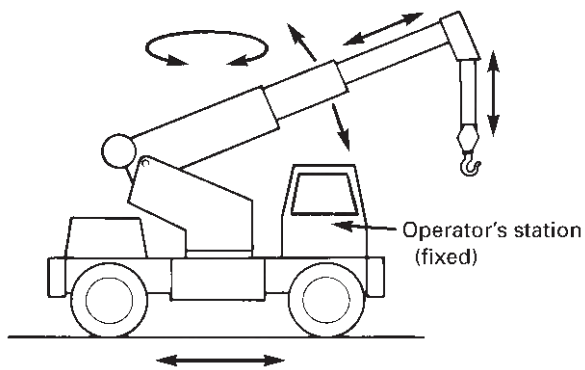

GENERAL NOTE: The boom may have a base boom structure of sections (upper and lower) between or beyond which additional sections may be added to increase its length, or it may consist of a base boom from which one or more boom extensions are telescoped for additional length.

mounted on top of a lower main boom. This is distinguished from a fixed jib, where the operating angle cannot be changed during operation. Typically, the lower boom operating angle can also be changed.

mast (boom): a frame hinged at or near the boom hinge for use in connection with supporting a boom. The head of the mast is usually supported and raised or lowered by the boom hoist ropes.

mast (jib): a frame hinged at or near the boom point for use in connection with supporting a jib.

maximum horizontal reach: the maximum horizontal distance the crane configuration can reach during load lifting or boom raising/lowering operations.

minimum breaking force: the minimum load at which a new and unused wire rope will break when loaded to destruction in direct tension.

mounting base: the traveling base on which the rotating superstructure is mounted.

multiple load line operation: simultaneous use of two or more lines reeved over sheaves on a single shaft or multiple shafts of a crane with multiple load drums to lift, rotate, or hold a single load.

normal operating conditions: conditions during which equipment is performing functions within the manufacturer's operating recommendations. Under these conditions, the operator is at an operator control station described in the instructions for the equipment; no other persons, except those designated, are to be on the equipment.

operational aid: an accessory that provides information to facilitate operation of the equipment or that takes control of particular functions without action of the operator when a limiting condition is sensed. Examples of such devices include, but are not limited to, the following: anti-two-block device, rated capacity indicator, rated capacity (load) limiter, boom angle or radius indicator, lattice boom hoist disconnect device, boom length indicator, crane level indicator, drum rotation indicator, load indicator, and wind speed indicator.

outriggers: extendable or fixed members attached to the mounting base, which rest on supports at the outer ends used to support the equipment.

pawl (dog): a device that engages a ratchet to prevent rotation.

payload: the load or loads being transported by the commercial truck chassis from place to place.

pendant: a rope, strand, or bar of specified length with fixed end connections.

power-controlled lowering: a system or device in the power train, other than the load hoist brake, that can control the lowering rate of speed of the load hoist mechanism.

qualified person: a person who, by possession of a recognized degree in an applicable field or certificate of professional standing, or who, by extensive knowledge, training, and experience, has successfully demonstrated the ability to solve or resolve problems relating to the subject matter and work.

radius: the distance from the axis of rotation of the superstructure to the center of gravity of the load.

rail clamp: a tong-like metal device mounted on a locomotive crane car, which can be connected to the track.

rated capacity: the maximum allowable load the equipment can lift at any given radius.

rated capacity indicator: a device that automatically monitors radius, load weight, and load rating and warns the crane operator of an overload condition.

rated capacity (load) limiter: a device that automatically monitors radius, load weight, and load rating and prevents movements of the crane, which would result in an overload condition.

reeving: a rope system in which the rope travels around drums and sheaves to provide a mechanical advantage for a hoist.

repetitive pickup point: when operating on a short cycle operation, the rope being used on a single layer and being spooled repetitively over a short portion of the drum.

rope: refers to wire rope unless otherwise specified.

rotation-resistant wire rope: stranded wire rope consisting of at least two layers of strands where the outer layer of strands is laid opposite to the underlying layer. The design results in a reduction in load-induced torque.

running rope: a rope that travels around sheaves or drums.

shall: a word indicating a requirement.

should: a word indicating a recommendation.

side loading: the component of a load applied horizontally and normal to the plane containing the axis of superstructure rotation and the centerline of the undeflected boom.

standby crane: a crane not in regular service that is used occasionally or intermittently as required.

standing rope: a supporting rope that maintains a constant distance between the points of attachment to the two components connected by the rope.

structural competence: the ability of the equipment and its components to withstand the stresses imposed by applied and dynamic loads.

superstructure: that portion of the equipment that rotates.

swing: rotation of the superstructure for movement of loads in a horizontal direction about the axis of rotation.

swing mechanism: the machinery involved in providing rotation of the superstructure.

swivel: a load-carrying member with thrust bearings to permit rotation under load in a plane perpendicular to the direction of the load.

tackle: an assembly of ropes and sheaves arranged for lifting, lowering, and pulling.

telescoping boom: a boom in which one or more boom sections are telescoped for additional length.

transit: the moving or transporting of equipment from one jobsite to another.

travel: the function of the equipment moving under its own power from one location to another on a jobsite.

two-block damage prevention feature: a system that will stall when two-blocking occurs without causing damage to the hoist rope or machinery components.

two-blocking: the condition in which the lower load block or hook assembly comes in contact with the upper load block or boom point sheave assembly.

two-block warning feature: a warning device to alert the operator of an impending two-blocking condition.

upper load block: the assembly of shackle, swivel, sheaves, pins, and frame suspended from the boom point.

whip line (auxiliary): a secondary rope system usually of lighter load capacity than that provided by the main rope system.

winch head: a power-driven spool for handling loads by means of friction between fiber or wire rope and the spool.

working load: the external weight applied to the equipment, including the weight of the attaching equipment such as the lower load block, shackles, and slings.

SECTION 5-0.3: PERSONNEL COMPETENCE

Persons performing the functions identified in this Volume shall meet the applicable qualifying criteria stated in this Volume and shall, through education, training, experience, skill, and physical fitness, as necessary, be competent and capable to perform the functions as determined by the employer or employer's representative.

SECTION 5-0.4: REFERENCES

(18)

The following is a list of publications referenced in this Standard:

ANSI Z26.1-1996, Safety Code for Glazing Materials for Glazing Motor Vehicles Operating on Land Highways
 Publisher: American National Standards Institute (ANSI),
 25 West 43rd Street, New York, NY 10036
 (www.ansi.org)

ASME B30.8-2010, Floating Cranes and Floating Derricks
 ASME B30.10-2009, Hooks

ASME B30.23-2011, Personnel Lifting Systems

ASME B30.26-2010, Rigging Hardware

Publisher: The American Society of Mechanical Engineers (ASME), Two Park Avenue, New York, NY 10016-5990
 (www.asme.org)

ASTM A1023/A1023M, Standard Specification for Stranded Carbon Steel Wire Ropes for General Purposes

Publisher: American Society for Testing and Materials (ASTM International), 100 Barr Harbor Drive, P.O. Box C700, West Conshohocken, PA 19428-2959 (www.astm.org)

AWS D14.3/D14.3M-2010, Welding Specifications for Earth Moving and Construction Equipment
Publisher: American Welding Society (AWS), 8669 NW 36 Street, No. 130, Miami, FL 33166 (www.aws.org)

ISO 7000, Graphical symbols for use on equipment — Registered symbols
ISO 7296, Cranes — Graphic symbols
Publisher: International Organization for Standardization (ISO), Central Secretariat, Chemin de Blandonnet 8, Case Postale 401, 1214 Vernier, Geneva, Switzerland (www.iso.org)

SAE J765–Oct. 1990, Crane Load Stability Test Code
SAE J987–Aug. 2012, Crane Structures — Method of Test

SAE J1028–Oct. 1998, Mobile Crane Working Area Definitions

SAE J1063–Nov. 1993, Cantilevered Boom Crane Structures — Method of Test

SAE J1977–Apr. 1997, Braking Performance — Rubber-Tired, Self-Propelled Cranes

SAE J2703, Crane — Access and Egress
Publisher: SAE International, 400 Commonwealth Drive, Warrendale, PA 15096 (www.sae.org)

U.S. DOT Safety Appliance Standards and Power Brakes Requirements (January 1973, Revised September 1977), DOT Standards, Federal Railroad Administration, United States Department of Transportation (DOT) (www.dot.gov)

Publisher: Superintendent of Documents, U.S. Government Printing Office (GPO), 732 N. Capitol Street, NW, Washington, DC 20401 (www.gpo.gov)

Chapter 5-1

Construction and Characteristics

SECTION 5-1.1: LOAD RATINGS AND TECHNICAL INFORMATION

(a) The crane manufacturer shall provide load rating charts and information for all crane configurations for which lifting is permitted.

(b) The manufacturer shall provide instructions for the proper assembly, disassembly, operation, inspection, and maintenance of the crane.

(c) The wire rope information listed in [para. 5-1.1.4\(b\)](#) shall be provided by the crane manufacturer for any ropes supplied with the crane. If wire rope is supplied by someone other than the crane manufacturer, the wire rope information shall be provided by the rope supplier.

(d) Under certain load conditions, torsion induced in a carbody or carrier frame can cause it to twist, resulting in an opposite side outrigger or portion of a crawler lifting free from the supporting surface. This condition does not indicate a loss of stability when working within the limits of the load rating chart. If this condition exists for any crane, the manufacturer shall describe this condition and provide instructions for continued operation when such liftoff occurs.

5-1.1.1 Load Ratings — Where Stability Governs Lifting Performance

(a) The margin of stability for determination of load ratings, with booms of stipulated lengths at stipulated working radii for the various types of crane mountings, shall be established by taking a percentage of the loads that will produce a condition of tipping or balance with the boom in the least stable direction relative to the mounting. With the indicated types of mounting under conditions stipulated in [\(c\)](#) and [\(d\)](#) below, the load ratings shall not exceed the percentages for cranes given in [Table 5-1.1.1-1](#).

(b) Lifting in excess of any specified load or radius limit, in directions other than the least stable, may result in overload of the crane components before the crane begins to tip.

(c) The following stipulations shall govern the application of the values in [\(a\)](#) above for locomotive cranes:

(1) The crane shall be standing on a track that is level within 1% grade.

(2) The radius of the load is the horizontal distance from a projection of the axis of rotation to the rail support surface, before loading, to the center of the vertical hoist line or tackle with load applied.

(3) Tipping loads from which ratings are determined shall be applied under static conditions only, i.e., without the dynamic effect of lifting, lowering, swinging, or booming.

(4) The weight of all auxiliary handling devices such as lower load block, hooks, and slings shall be considered as part of the load.

(d) Stipulations governing the application of the values in [\(a\)](#) above shall be in accordance with SAE J765.

(e) The effectiveness of these preceding stability factors will be influenced by such additional factors as freely suspended loads; track, wind, or ground conditions; condition and inflation of rubber tires; boom lengths; proper operating speeds for existing conditions; and, in general, careful and competent operation. Any standard attachments to the boom such as jibs and auxiliary or whip lines shall be considered as affecting stability, and a deduction shall be made from load ratings in accordance with the manufacturer's instructions. The effect of lights, pile lead adaptors, or other nonstandard attachments shall also be deducted from load ratings. All of these shall be taken into account.

(f) When cranes included in the scope of B30.5 are mounted on barges or pontoons, factors in addition to those stipulated in [paras. 5-1.1.1](#) and [5-1.1.2](#) will influence the stability and structural competence. The load rating for a crane on a barge or pontoon shall be modified as recommended by the manufacturer or a qualified person (refer to ASME B30.8).

5-1.1.2 Load Ratings — Where Factors Other Than Stability Govern Lifting Performance

Load ratings may be based on structural, mechanical, hydraulic, electrical, pneumatic, or limitations other than stability. The working margins associated with these load ratings vary depending on the crane configuration, the lifting radius, and the specific system component that is affected.

Table 5-1.1.1-1 Crane Load Ratings

Type of Crane Mounting	Maximum Load Rating, %
Locomotive, without outrigger support [Note (1)]	
Booms 60 ft (18 m) or less	85
Booms over 60 ft (18 m)	85 [Note (2)]
Locomotive, using outriggers fully extended and set	80
Crawler, without outrigger support	75
Crawler, using outriggers fully extended and set	85
Wheel mounted, without outrigger support	75
Wheel mounted, using outriggers fully extended and set, with tires off supporting surface	85
Wheel mounted, using outrigger beams partially extended and set, with tires off supporting surface	Notes (3) and (4)
Commercial truck vehicle mounted, with outrigger extended and set	85
Commercial truck mounted, using outrigger partially extended and set	Notes (3) and (4)

NOTES:

- (1) As a precaution while testing for free ratings, outriggers should be loosely applied; rail clamps should not be used.
- (2) The difference between the backward stability moment and the forward moment resulting from the load should not be less than 30,000 lb-ft (40 675 N·m) with the backward stability moment being the greater.
- (3) The following equation shall be used for less than full extension of all outrigger beams to find the rated capacity:

$$P \leq (T - 0.1F)/1.25$$

where

- F* = load applied at boom tip that gives the same moment effect as boom mass
- P* = rated capacity in the lifting direction specified
- T* = tipping load

- (4) If crane operation with outriggers in positions other than fully extended is permitted by the crane manufacturer, specified procedures, ratings, and limitations for any configurations that are permitted shall be provided.

5-1.1.3 Load Rating Chart

(18)

(a) Load rating charts shall be marked with a serial number, part number, or other traceable method that allows for the matching of charts to a specific crane(s).

(b) A durable load rating chart(s) with legible letters and figures shall be provided in paper, plastic, metal, or electronic display form with each crane and attached in a location accessible to the operator while at the controls. The data and information to be provided on these charts shall include, but not be limited to, the following:

(1) a full and complete range of manufacturer's crane load ratings at all stated operating radii, boom angles, work areas, boom lengths and configurations, jib lengths and angles (or offset), as well as alternate ratings for use and nonuse of optional equipment on the crane, such as outriggers and extra counterweights, which affect ratings

(2) a work area chart for which capacities are listed in the load rating chart (see Figure 5-1.1.3-1)¹

(3) if crane specifications include ratings for lifting in directions other than the least stable, the work area limitations corresponding to such additional ratings shall be clearly defined

(4) in areas where no load is to be handled, the work area figure and load rating chart shall so state

(5) recommended reeving for the hoist lines

(6) the diameter, rotation resistant or non-rotation resistant, minimum breaking force, and the maximum allowable load per line for hoist ropes

(7) if the weight of any portion of the hoist rope is required to be considered as part of the crane's lifted load, the method for determining such rope weight shall be provided

(8) cautions, warnings, and notes relative to limitations on the load ratings

(9) position of the gantry and requirements for intermediate boom suspension, where applicable

(10) maximum loads permitted during the actual boom extending operation, and any limiting conditions or cautions, where applicable

(11) tire pressure, where applicable

(12) identification of all forward and backward stability limitations and requirements relating to assembly, disassembly, setup, operation, inspection, and maintenance

5-1.1.4 Additional Information

(18)

(a) In addition to the data required on the load rating chart, the following information shall be provided either with the load rating chart or in the operating manual:

(1) recommended parts of load hoist reeving, a reeving diagram, and the rope length for all hoist drums on the crane

¹ Illustrations (a) through (d) of Figure 5-1.1.3-1 are reproduced from ANSI/SAE J1028 © 1998 SAE International.

(18)

Figure 5-1.1.3-1 Work Areas

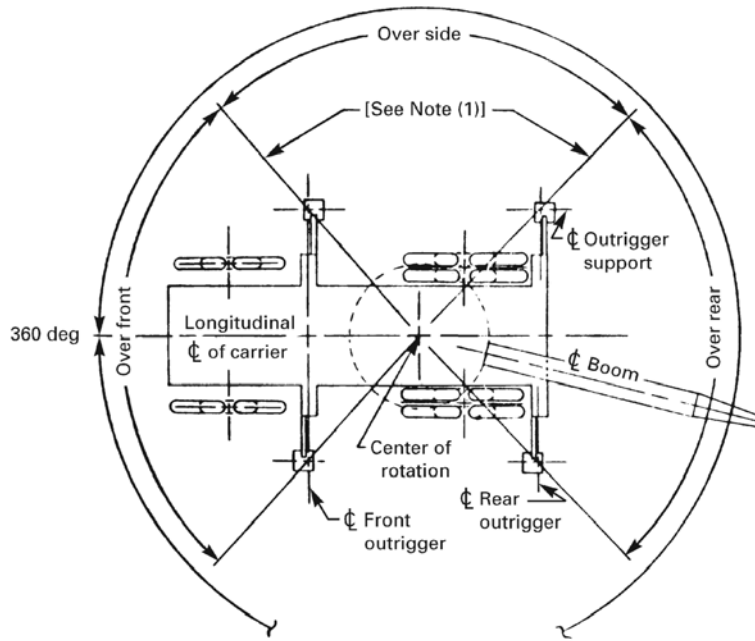

(a) Carrier on Outriggers — Front Outrigger Behind Front Wheels [Note (2)]

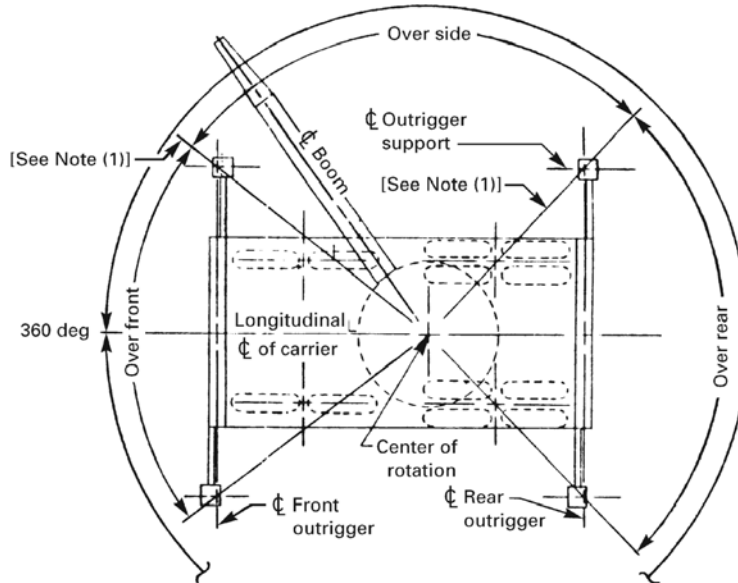

(b) Carrier on Outriggers — Front Outrigger Ahead of Front Wheels [Note (2)]

Copyright © SAE International

(18)

Figure 5-1.1.3-1 Work Areas (Cont'd)

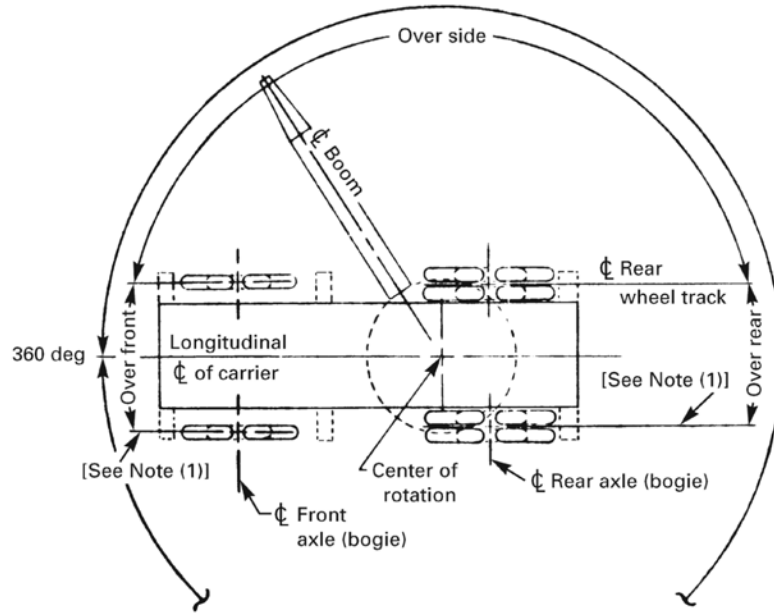

(c) Carrier on Tires [Note (2)]

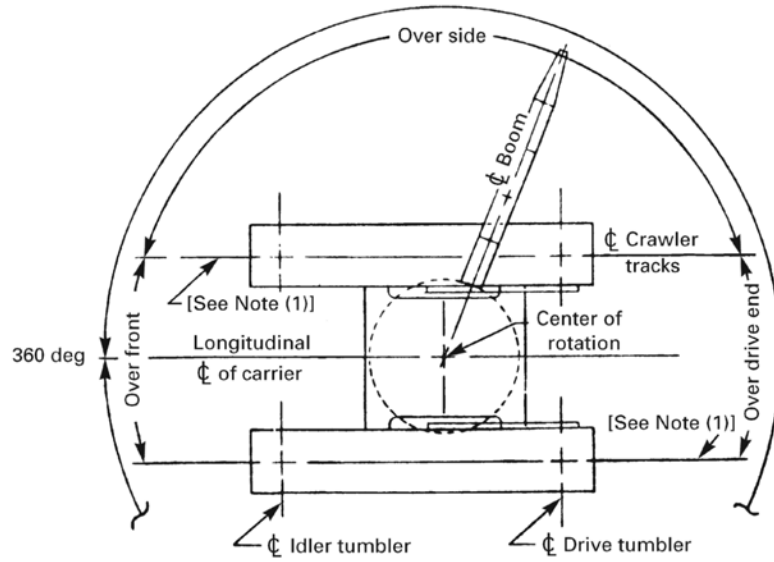

(d) Crawler Type Lower [Note (2)]

Copyright © SAE International

(18)

Figure 5-1.1.3-1 Work Areas (Cont'd)

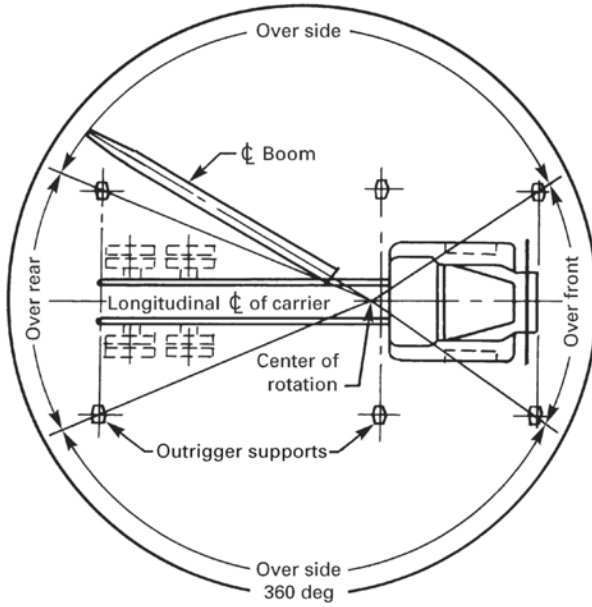

(e) Notes (1) and (2)

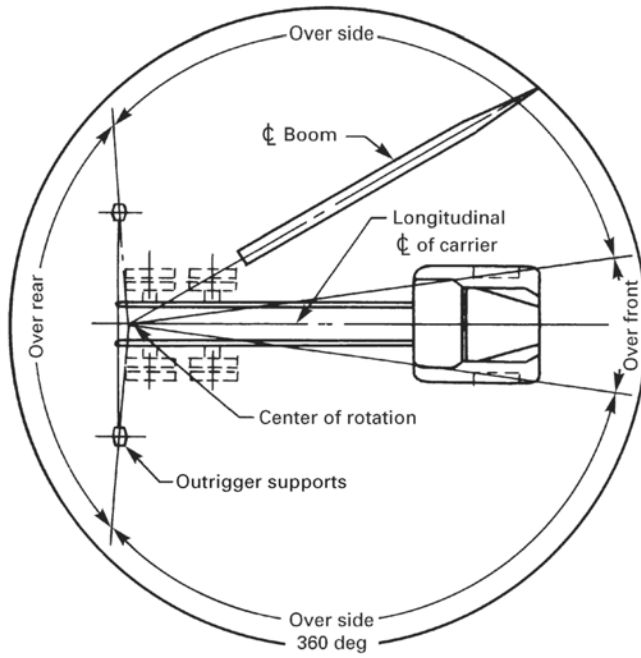

(f) Notes (1) and (2)

(18)

Figure 5-1.1.3-1 Work Areas (Cont'd)

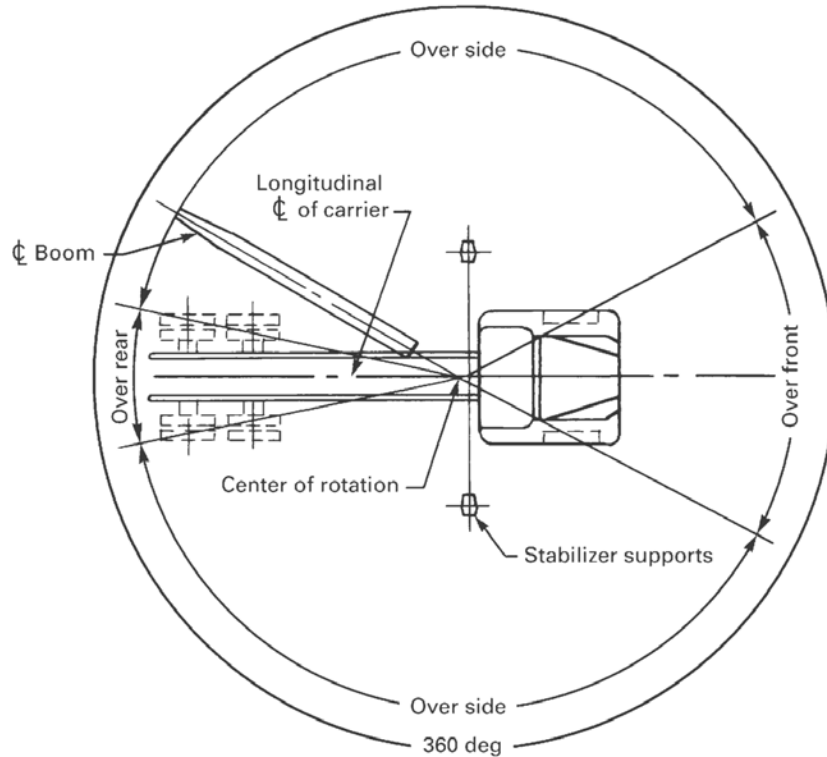

(g) Notes (1) and (2)

NOTES:

- (1) These lines determine the limiting position of any load for operation within the working areas indicated.
- (2) Configurations that deviate sufficiently from the work areas shown in Figure 5-1.1.3-1 shall have their working areas indicated by appropriate sets of diagrams supplied by the manufacturer.

(2) recommended boom hoist reeving, reeving diagram, and length of rope where applicable

(3) cautions, warnings, and notes relative to limitations on equipment, crane setup, and operating procedures, including indication of the least stable direction

(4) crane leveling instructions and specifications

(5) instructions for boom erection and conditions under which the boom or boom and jib combinations may be raised or lowered

(6) whether the hoist holding mechanism is automatically controlled, manually controlled, whether free-fall is available, or any combination thereof

(7) the maximum telescopic travel length of each boom telescopic section

(8) whether sections are telescoped with power or manually

(9) the sequence and procedure for extending and retracting the telescopic boom section

(10) hydraulic relief valve settings specified by the manufacturer

(11) if an outrigger(s) or portion of a crawler is permitted to lift free of its supporting surface while working within the limitations specified on the load rating chart, instructions shall be provided for continued operation when such liftoff occurs

(b) The information listed below shall be provided in legible form for the wire rope installed on each drum. A wire rope test certificate may be provided in lieu of the following individual items:

(1) rope diameter [e.g., 1 in. (25 mm)]

(2) type and construction (e.g., filler wire, Seale, rotation resistant)

(3) classification (e.g., 6 × 19, 34 × 7)

(4) rope grade (IPS, EEIP, 1770)

(5) rope core (e.g., IWRC, fiber core)

(6) direction and lay (e.g., RRL, LAL)

(7) minimum breaking force (e.g., 54 tons, 480 kN)

(8) weight per foot

(9) drum designation

(10) rope length

(18) SECTION 5-1.2: BACKWARD STABILITY**5-1.2.1 General Conditions**

The general conditions for determination of the backward stability margin, applicable to all cranes within the scope of this Chapter, are as follows:

- (a) crane to be equipped for crane operation with shortest recommended boom
- (b) boom positioned at maximum recommended boom angle
- (c) crane to be unloaded (lower load block on support)
- (d) outriggers free of the bearing surface when the crane is counterweighted for “on tires or on wheels” operation unless specified by the manufacturer for stationary use
- (e) crane to be standing on a firm supporting surface, level within 1% grade; locomotive cranes to be standing on a level track
- (f) all fuel tanks to be at least half full and all other fluid levels as specified

5-1.2.2 Minimum Backward Stability Criteria

The following are minimum acceptable backward stability criteria:

(a) *Locomotive Cranes.* The horizontal distance between the center of gravity of the crane and the axis of rotation shall not exceed 39% of the track gage.

(b) *Crawler Cranes.* The horizontal distance between the center of gravity of the crane and the axis of rotation shall not exceed 70% of the radial distance from the axis of rotation to the backward tipping fulcrum in the least stable direction.

(c) *Wheel-Mounted Cranes (Counterweighted for “on Tires or on Wheels” Operation)*

(1) With the longitudinal axis of the rotating superstructure of the crane at 90 deg to the longitudinal axis of the carrier, the total load on all wheels on the side of the carrier under the boom shall not be less than 15% of the total weight of the crane.

(2) With the longitudinal axis of the rotating superstructure of the crane in line with the longitudinal axis of the carrier in either direction, the total load on all wheels under the lighter loaded end of the carrier shall not be less than 15% of the total weight of the crane in the manufacturer’s specified work area and not be less than 10% of the total weight of the crane in an area not specified as a work area (see [Figure 5-1.1.3-1](#)).

(d) *Wheel-Mounted Cranes (Counterweighted for “on Outrigger” Operation).* Under the conditions of [paras. 5-1.2.1\(a\) through 5-1.2.1\(c\), 5-1.2.1\(e\), and 5-1.2.1\(f\)](#), and with the machine supported level on fully extended outriggers with all tires free of the supporting surface, the resistance to overturning in a backward direction shall be equivalent to those conditions specified in [\(c\)\(1\) and \(c\)\(2\)](#) above.

SECTION 5-1.3: BOOM HOIST, LOAD HOIST, AND TELESCOPING BOOM MECHANISMS**5-1.3.1 Boom Hoist Mechanism**

The boom hoist may use a rope drum for its drive or hydraulic cylinder(s), and the supporting structure may be a gantry or the same hydraulic cylinder(s) used to elevate the boom.

(a) The boom hoist shall be capable of elevating and controlling the boom with its rated load (for rope boom hoists when reeved according to the manufacturer’s specifications) and shall be capable of supporting the boom and rated load without action by the operator.

(b) In a rope-supporting and -elevating arrangement, boom lowering shall be done only under power control. Free-fall lowering of the boom shall not be permitted.

(1) The boom hoist drum shall have sufficient rope capacity to operate the boom in all positions, from the lowest permissible to the highest recommended, when using the manufacturer’s recommended reeving and rope size. No less than two full wraps of rope shall remain on the drum with the boom point lowered to the level of the crane-supporting surface. The drum end of the rope shall be anchored to the drum by an arrangement specified by the crane or rope manufacturer.

(2) The drum shall provide a first layer rope pitch diameter of not less than 15 times the nominal diameter of the rope used.

(c) On rope boom support machines, a braking mechanism and a ratchet and pawl or other locking device shall be provided to prevent inadvertent lowering of the boom.

(d) An integrally mounted holding device (such as a load hold check valve) shall be provided with boom support hydraulic cylinder(s) to prevent uncontrolled lowering of the boom in the event of a hydraulic system failure (e.g., supply hose rupture).

5-1.3.2 Load Hoist Mechanism

(18)

The hoist mechanism may consist of a drum or hydraulic cylinder(s) with necessary rope reeving.

(a) *Load Hoist Drums.* The load hoist drum assemblies shall have power and operational characteristics sufficient to perform all load lifting and lowering functions required in crane service when operated under recommended conditions.

(1) Where brakes and clutches are used to control the motion of the load hoist drums, they shall be of a size and thermal capacity sufficient to control all rated crane loads with minimum recommended reeving (where maximum rated loads are being lowered with near maximum boom length or operations involving long lowering distances, power-controlled lowering is usually desirable to reduce demand on the load brake).

Brakes and clutches shall be provided with adjustments where necessary to compensate for lining wear and to maintain force in springs, where used.

(2) Load hoist drums shall have rope capacity with the recommended rope size and reeving sufficient to perform crane service within the range of boom lengths, operating radii, and vertical lifts specified by the manufacturer.

(-a) No less than two full wraps of rope shall remain on the drum when the hook is in the extreme low position.

(-b) The drum end of the rope shall be anchored to the drum by an arrangement specified by the crane or rope manufacturer.

(-c) The drum flange shall extend a minimum one-half rope diameter or $\frac{1}{2}$ in. (13 mm), whichever is greater, over the top working layer of rope.

(3) The load hoist drums shall provide a first layer rope pitch diameter of not less than 18 times the nominal diameter of the rope used.

(4) A means controllable from the operator's station shall be provided to hold the drum from rotating in the lowering direction and be capable of holding the rated load without further action by the operator. Foot-operated brakes having a continuous mechanical linkage between the actuating and braking means, capable of transmitting full braking force, and equipped with a positive mechanical means to hold the linkage in the applied position, meet this requirement.

(5) Drum rotation indicators should be provided and located to afford sensing by the operator.

(b) *Load Hoist Brakes*

(1) When power-operated brakes having no continuous mechanical linkage between the actuating and braking means are used for controlling loads, an automatic means shall be provided to set the brake to prevent the load from falling in the event of loss of brake control power.

(2) Foot-operated brake pedals shall be constructed so that the operator's feet, when in proper position, will not slip off, and a means shall be provided for holding the brakes in the applied position without further action by the operator.

(c) *Power-Controlled Lowering.* When provided, a power-controlled lowering system shall be capable of handling rated loads and speeds as specified by the manufacturer. Such a system is recommended to assist in precision lowering and to reduce demand on the load brake.

(d) *Cylinders With Rope Reeving.* Cranes using a load hoist mechanism with hydraulic cylinder(s) and rope reeving shall have power and operational characteristics sufficient to perform all load lifting and lowering functions required in crane service when operated under recommended conditions. Sheaves used in multiple rope reeving shall have a pitch diameter not less than 16

times the nominal diameter of the rope and shall comply with [para. 5-1.7.4](#).

5-1.3.3 Telescoping Boom

(a) Extension and retraction of boom sections may be accomplished through hydraulic, mechanical, or manual means.

(b) The powered retract function shall be capable of controlling any rated load that can be retracted.

(c) An integrally mounted holding device (such as a load hold check valve) shall be provided with the telescopic hydraulic cylinder(s) to prevent uncontrolled retraction of the boom in the event of a hydraulic system failure (e.g., supply hose rupture).

SECTION 5-1.4: SWING MECHANISM

5-1.4.1 Swing Control

The swing mechanism shall start and stop with controlled acceleration and deceleration.

5-1.4.2 Swing Braking Means and Locking Device

(a) A braking means with holding power in both directions shall be provided to restrict movement of the rotating superstructure, when desired during normal operation. The braking means shall be capable of being set in the holding position and remaining so without further action by the operator.

(b) A device or boom support shall be provided to prevent the boom and superstructure from rotating when in transit. It shall be constructed to minimize inadvertent engagement or disengagement.

SECTION 5-1.5: CRANE TRAVEL

5-1.5.1 Travel Controls

(a) On all crane types with a single control station, the controls for the travel function shall be located at the operator's station.

(b) On all wheel-mounted multiple control station cranes, the travel controls shall be located in the carrier cab. Auxiliary travel controls may also be provided in the crane cab. If there is an operator in the crane cab when the crane is traveling, communication shall be provided between the cabs. Use of audible signaling devices will meet this requirement.

5-1.5.2 Travel Mechanism

(a) On locomotive cranes, when the travel mechanism must be temporarily deactivated in the normal course of the requirements of the user, provision shall be made to disengage the travel mechanism from the cab or outside the crane body.

(b) On a crawler crane, the travel and steering mechanism shall be arranged so that it is not possible for both crawlers to freewheel without operator control. Control shall be effected from the operator's position on the revolving superstructure.

5-1.5.3 Travel Brakes and Locks

(a) On crawler cranes, brakes or other locking means shall be provided to hold the machine stationary during working cycles on a level grade or while the machine is standing on the maximum grade recommended for travel. Such brakes or locks shall be arranged to remain in engagement in the event of loss of operating pressure or power.

(b) On locomotive cranes, brakes shall be provided to bring the crane to a stop while descending the maximum grade recommended for travel. Also, manual brake engagement means shall be provided to hold the machine stationary on the maximum grade recommended for travel. Such means shall be arranged to remain in engagement in the event of loss of operating air pressure.

(c) On wheel-mounted cranes, brakes shall be provided to bring the machine to a stop. Braking performance shall comply with the requirements of SAE J1977.

(d) On wheel-mounted cranes, means shall be provided to control completely the crane carrier travel when descending maximum grades specified by the manufacturer under maximum loading conditions. Where long or steep grades are to be negotiated, a retarder or similar device should be provided. Means shall be provided to hold the machine stationary on the maximum grade for travel recommended by the manufacturer.

(e) Where travel brakes are operated by air pressure, means shall be provided for manually or automatically stopping the vehicle when the operating pressure falls below the specified minimum level.

(f) Vehicle-mounted cranes on commercial trucks shall meet the requirements of the U.S. Department of Transportation standards.

SECTION 5-1.6: CONTROLS

5-1.6.1 General

(a) Basic controls (see Figures 5-1.6.1-1 and 5-1.6.1-2) used during the crane operating cycle shall be located within reach of the operator while at the operator's station and labeled as to their designated function and direction of movement.

(b) Controls for load hoist, boom hoist, swing, and boom telescope (when applicable) shall be provided with means for holding in the neutral position, without the use of positive latches.

(c) On machines equipped with telescoping-type booms, the arrangements of controls should be as shown in Figure 5-1.6.1-1. On machines not equipped with telescoping-type booms, the arrangements of controls should be as shown in Figure 5-1.6.1-2.

(d) Remote-operated cranes shall function so that if the control signal for any crane motion becomes ineffective, the crane motion shall stop.

(e) Provisions shall be made for emergency stop in the event of a device malfunction for remote-operated cranes.

5-1.6.2 Control Forces and Movements

(a) Forces shall be not greater than 35 lb (156 N) on hand levers and not greater than 50 lb (222 N) on foot pedals.

(b) Travel distance on hand levers shall be not greater than 14 in. (356 mm) from neutral position on two-way levers and not greater than 24 in. (610 mm) on one-way levers. Travel distance on foot pedals shall be not greater than 10 in. (254 mm).

5-1.6.3 Power Plant Controls

Controls for operating a superstructure mounted power plant shall be within reach of the operator and shall include the means to

- (a) start and stop
- (b) control the speed of internal combustion engines
- (c) stop two-cycle diesel engines under emergency conditions
- (d) shift selective transmissions

5-1.6.4 Engine Clutch

All cranes with a direct mechanical or hydrodynamic (such as torque converter or fluid coupling) drive to any crane function shall be provided with a clutch or other means for disengaging power. The controls shall be within reach of the operator's station.

SECTION 5-1.7: ROPES AND REEVING ACCESSORIES

5-1.7.1 Rope Design Factors

(a) For supporting rated loads and for supporting the boom and working attachments at recommended travel or transit positions and boom lengths

(1) the design factor for live or running ropes that wind on drums or travel over sheaves shall be not less than 3.5

(2) the design factor for boom pendants or standing ropes shall be not less than 3.0

(b) For supporting the boom under recommended boom erection conditions

(1) the design factor for live or running ropes shall be not less than 3.0

Figure 5-1.6.1-1 Telescopic Boom Crane Control Diagram (Suggested Mobile Telescopic Boom Crane Basic Operating Control Arrangement for New Cranes)

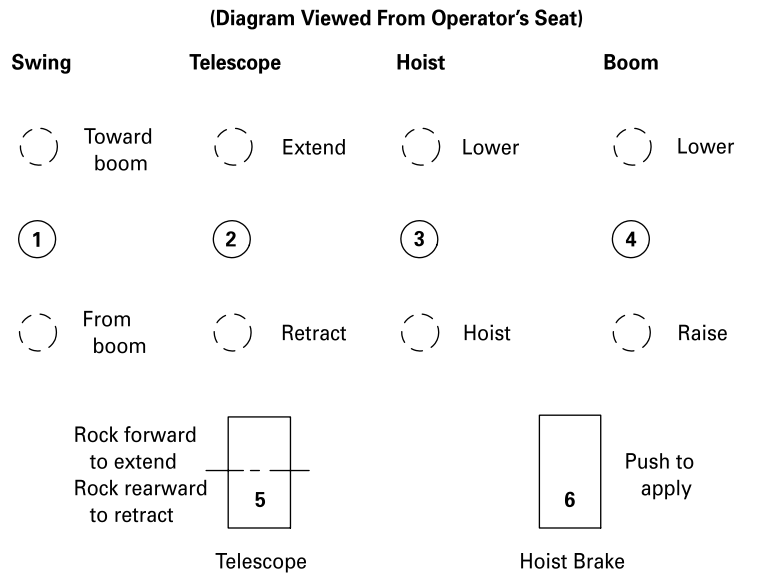

Control	Operation
1 Swing Control	Push forward to swing toward boom, swinging left for right-side operator position and right for left-side operator position. For centrally located operator, same as left-side operator position. Pull rearward for reverse action.
2 Telescope Control (If Applicable)	Push forward to extend telescopic boom. Center position to hold. Pull rearward to retract telescopic boom.
3 Mobile Control	Pull rearward to hoist. Center position may be held. Push forward to lower by power.
4 Boom Control	Pull rearward to raise boom. Center position to hold. Push forward to lower boom.
5 Telescope Pedal (If Applicable)	Rock pedal forward to extend telescopic boom. Center position to hold. Rock pedal rearward to retract telescopic boom.
6 Hoist Brake (If Applicable)	Push to stop or hold lowering load. Release to lower load.

GENERAL NOTES:

- (a) The control arrangement of [Figure 5-1.6.1-1](#) applies to mobile telescopic boom crane hand and foot controls.
- (b) The arrangement of the basic controls should be as shown in the control diagram. Controls 1 through 4 are levers for hand operation; controls 5 and 6 are pedals for foot operation, if applicable.
- (c) Controls for auxiliary functions, such as telescope and hoist, should be located adjacent to the main controls. Controls for all other functions should be positioned to avoid operator confusion and physical interference. Nothing in this recommended practice precludes the use of additional controls subject to the recommendations herein.
- (d) All basic controls should operate as specified in the control diagram. It is not the intent to limit the use thereof or to apply to combination, automatic, or other special operating control requirements.

Figure 5-1.6.1-2 Nontelescopic Boom Crane Control Diagram (Suggested Mobile Nontelescopic Boom Crane Basic Operating Control Arrangement for New Cranes)

(Diagram Viewed From Operator's Seat)

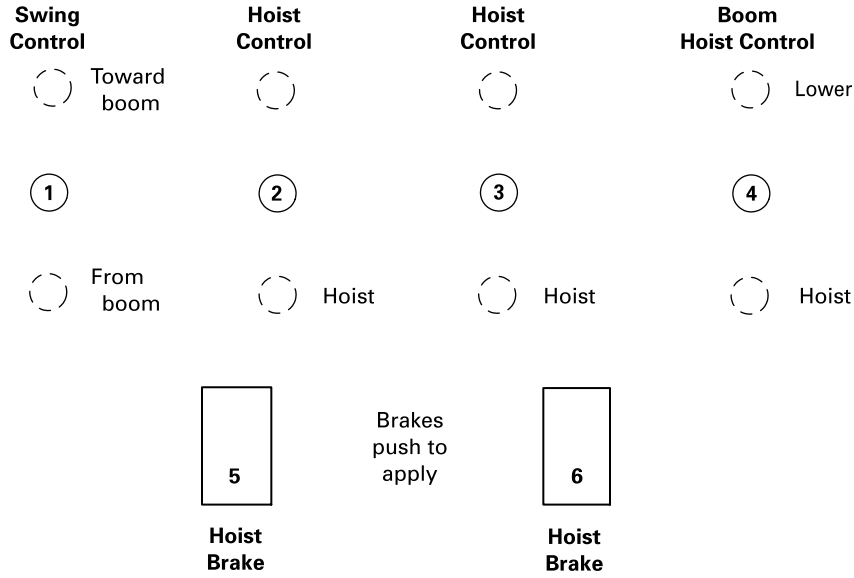

Control	Operation
1 Swing Control	Push forward to swing toward boom, swinging left for right-side operator position and right for left-side operator position. Pull back to reverse these actions.
2 Hoist Control	Pull back to hoist. Center (release) to lower by brake 5. Push forward to lower, if provided with powered load lowering on this drum.
3 Hoist Control	Pull back to hoist. Center (release) to lower by brake 6. Push forward to lower, if provided with powered load lowering on this drum.
4 Boom Hoist Control	Pull back to raise boom. Push forward to lower boom. Center (released) position must hold boom stationary even with boom safety pawl released.
5 Hoist Brake	Push to hold or stop lowering load. Release to lower load.
6 Hoist Brake	Push to hold or stop lowering load. Release to lower load.

GENERAL NOTES:

- (a) The control arrangement of [Figure 5-1.6.1-2](#) applies to mobile nontelescopic boom crane hand and foot controls.
- (b) The arrangement of the basic controls should be as shown in the control diagram. Controls 1 through 4 are levers for hand operation; controls 5 and 6 are pedals for foot operation, if applicable.
- (c) Controls for auxiliary functions, such as hoist, should be located adjacent to the main controls. Controls for all other functions should be positioned to avoid operator confusion and physical interference. Nothing in this recommended practice precludes the use of additional controls subject to the recommendations herein.
- (d) All basic controls should operate as specified in the control diagram. It is not the intent to limit the use thereof or to apply to combination, automatic, or other special operating control requirements.

(2) the design factor for boom pendants or standing ropes shall not be less than 2.5

(c) Rotation-resistant ropes shall have a design factor of 5 or greater. [The design factor of 5 or greater for rotation-resistant ropes may be modified by the crane user by complying with the provisions of [para. 5-3.2.1.1\(e\)](#).]

(d) The design factor specified in (a) through (c) above shall be the total minimum breaking force of all ropes in the system divided by the load imposed on the rope system when supporting the static weights of structure and crane rated load.

5-1.7.2 Ropes

(a) Ropes shall be in accordance with the requirements of the crane manufacturer, rope manufacturer, or a qualified person, and should be in accordance with ASTM A1023/A1023M.

(b) Fiber core ropes shall not be used for boom hoist or luffing attachment reeving.

(c) Rotation-resistant ropes shall not be used for boom hoist reeving as normally defined in [Section 5-1.3](#).

(d) Rotation-resistant ropes may be used as boom hoist reeving when load hoists are used as boom hoists for attachments such as luffing attachments or boom and mast attachment systems. Under these conditions, the following requirements shall be met:

(1) All the requirements of the boom hoist mechanism (see [para. 5-1.3.1](#)), with the exception of the drum, shall provide a first-layer rope pitch diameter of not less than 18 times the nominal diameter of the rope used.

(2) All the requirements of the load hoist mechanism (see [para. 5-1.3.2](#)).

(3) All sheaves used in the boom hoist reeving system shall have a rope pitch diameter of not less than 18 times the nominal diameter of the rope used.

(4) The design factor for the boom hoist reeving system shall not be less than 5.

(5) The design factor specified in (4) above shall be the total minimum breaking force of all parts of ropes in the system divided by the load imposed on the rope system when supporting the static weights of the structure and the crane rated load.

(6) The frequency of inspection of the wire rope shall be increased when using rotation-resistant rope in boom hoist or luffing attachment service.

(e) Rotation-resistant rope shall be given special care during installation as it is easily damaged.

(f) Socketing shall be done in the manner specified by the manufacturer of the wire rope or fitting.

(g) If a load is supported by more than one part of rope, the tension in the parts shall be equalized.

(h) Wherever exposed to ambient temperatures at the rope in excess of 180°F (82°C), rope having an independent wire-rope or wire-strand core, or other temperature damage-resistant core, shall be used.

5-1.7.3 Reeving Accessories

(a) Eye splices shall be made in a manner recommended by the rope or crane manufacturer, and rope thimbles should be used in the eye.

(b) Wire rope clips shall be drop-forged steel of the single-saddle- (U-bolt) or double-saddle-type clip. Malleable cast iron clips shall not be used. For spacing, number of clips, and torque values, refer to the clip manufacturer's recommendation. Wire rope clips attached with U-bolts shall have the U-bolt over the dead end of the rope and the live rope resting in the clip saddle. Clips shall be tightened evenly to the recommended torque. After the initial load is applied to the rope, the clip nuts shall be retightened to the recommended torque to compensate for any decrease in rope diameter caused by the load. Rope clip nuts should be retightened periodically to compensate for any further decrease in rope diameter during usage.

(c) Swaged, compressed, or wedge socket fittings shall be applied as recommended by the rope, crane, or fitting manufacturer. Any new poured socket or swaged socket assembly used as a boom pendant shall be proof tested to the crane or fitting manufacturer's recommendation, but in no case greater than 50% of the nominal strength of the component wire rope or structural strand.

(d) Wire rope clips used in conjunction with wedge sockets shall be attached to the unloaded dead end of the rope only (see [Figure 5-1.7.3-1](#)). This does not preclude the use of devices specially designed for dead ending rope in a wedge socket.

5-1.7.4 Sheaves

(a) Sheave grooves shall be free from surface defects that could cause rope damage. The cross-sectional radius at the bottom of the groove should be such as to form a close-fitting saddle for the size of rope used. The sides of the groove shall be tapered outward and rounded at the rim to facilitate entrance of the rope into the groove. Flange rims shall run true about the axis of rotation.

(b) Sheaves carrying ropes that can be momentarily unloaded shall be provided with close-fitting guards or other devices to guide the rope back into the groove when the load is reapplied.

(c) The sheaves in the lower load block shall be equipped with close-fitting guards that will prevent ropes from becoming fouled when the block is lying on the ground with loose ropes.

(d) All sheave bearings, except for permanently lubricated bearings, shall be provided with means for lubrication.

5-1.7.5 Sheave Sizes

(a) Boom-hoisting sheaves shall have pitch diameters of not less than 15 times the nominal diameter of the rope used, except as noted in [paras. 5-1.7.2\(c\)](#) and [5-1.7.2\(d\)](#).

Figure 5-1.7.3-1 Dead Ending Rope in a Socket

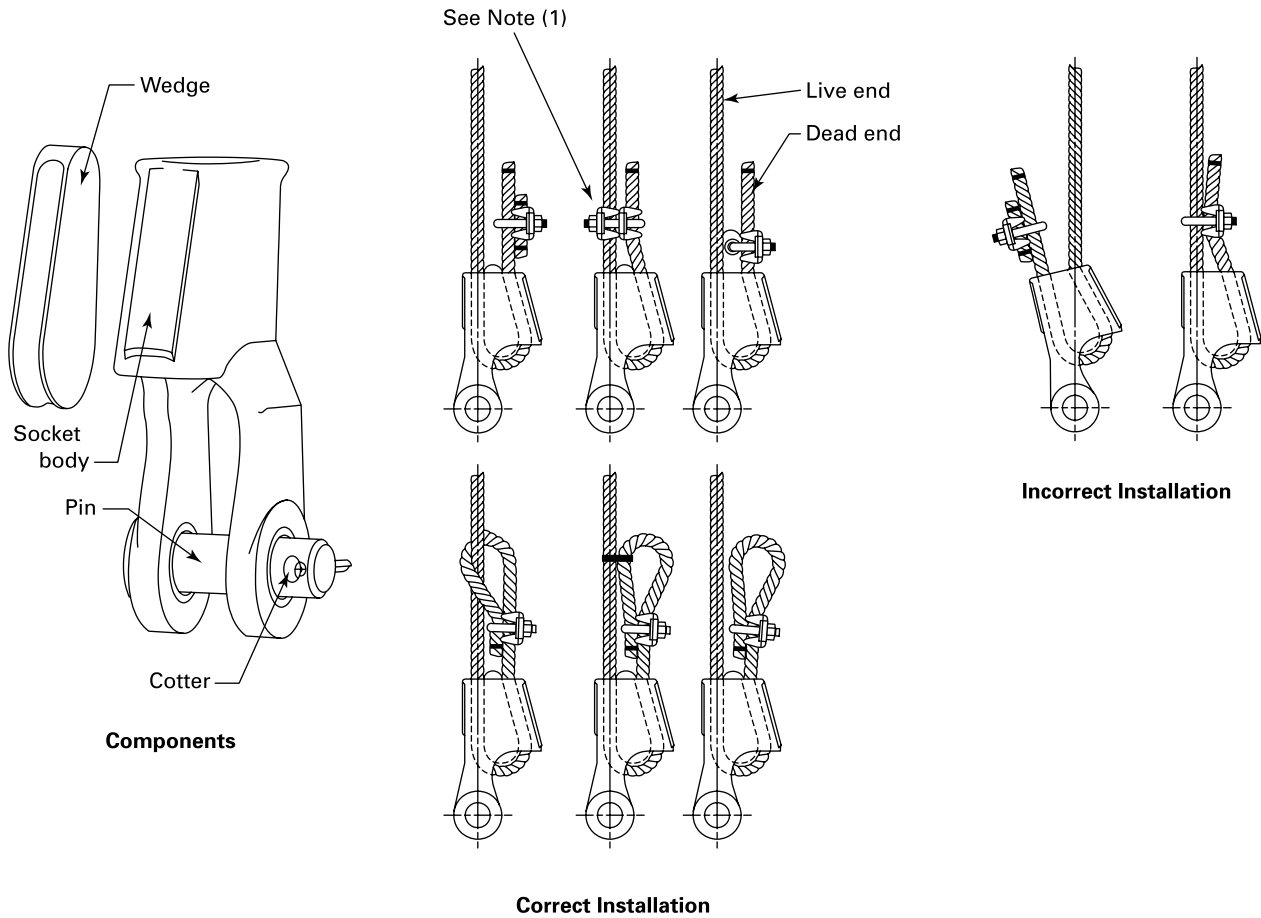

NOTE: (1) This type of clip must prevent crimping and damage to the live wire rope while stopping load transfer to the dead end.

(b) Load-hoisting sheaves shall have pitch diameters not less than 18 times the nominal diameter of the rope used.

(c) Load block (lower) sheaves shall have pitch diameters not less than 16 times the nominal diameter of the rope used.

5-1.7.6 Load Hook, Ball Assemblies, and Load Blocks

Load hooks, ball assemblies, and load blocks shall be of sufficient weight to overhaul the line from the highest hook position for boom or boom and jib lengths, and the number of parts of line in use. All hook and ball assemblies and load blocks shall be labeled with their rated capacity and weight. Hooks shall be equipped with latches unless the application makes the use of a latch impractical. When provided, the latch shall bridge the throat opening of the hook for the purpose of retaining slings or other lifting devices under slack conditions (refer to ASME B30.10).

SECTION 5-1.8: CABS

5-1.8.1 Construction

(18)

(a) Insofar as is practical, all cabs and enclosures shall be constructed to protect the superstructure machinery, brakes, clutches, and operator's station from the weather.

(b) Openings shall be provided in the front and on both sides of the cab or operator's compartment with visibility forward and to either side. Visibility forward shall include a vertical range adequate to cover the boom point at all times.

(c) When provided, windows shall be safety glazing material as defined in ANSI Z26.1. The front window may have a section that can be readily removed or held open, if desired. If the section is of the type held in the open position, it shall be secured to prevent inadvertent closure. A windshield wiper should be provided on the front window.

(d) All cab doors, whether of the sliding or swinging type, shall be restrained from inadvertent opening or closing while traveling or operating the machine. The

door adjacent to the operator, if of the swinging type, should open outward and, if of the sliding type, should slide rearward to open.

(e) A clear passageway shall be provided from the operator's station to an exit door on the operator's side.

(f) On wheel-mounted cranes, a seat belt shall be provided at each control station containing travel controls.

5-1.8.2 Platforms to Cab

(a) Principal walking surfaces shall be of a skid-resistant type.

(b) Outside platforms, if furnished, shall be provided with guardrails in accordance with SAE J2703. Where platforms are too narrow to use guardrails, handholds shall be provided at convenient points above the platform.

5-1.8.3 Access to Cab

(a) On locomotive cranes, handholds and steps shall be provided for access to the car and cab. Their construction shall conform to the requirements of the Safety Appliance Standards and Power Brakes Requirements of the Federal Railroad Administration.

(b) On all crawler and wheel-mounted cranes, handholds, steps, or both shall be provided, as needed, to facilitate entrance to and exit from the operator's cab and the carrier cab.

(c) Principal walking surfaces shall be of a skid-resistant type.

5-1.8.4 Cab Roof

Where necessary for rigging or service requirements, a ladder or steps shall be provided to give access to the cab roof. The ladder or steps shall conform to the requirements of SAE J2703. Where necessary, areas of the cab roof shall be capable of supporting, without permanent distortion, the weight of a 200 lb (90 kg) person.

SECTION 5-1.9: GENERAL REQUIREMENTS

5-1.9.1 Booms

(a) *Boom Stops.* Stops shall be provided to resist the boom falling backwards. Boom stops should be of one of the following types:

- (1) a fixed or telescoping bumper
- (2) a shock-absorbing bumper
- (3) hydraulic boom elevation cylinder(s)

(b) Jibs shall be restrained from backward overturning.

(c) A boom angle or radius indicator readable from the operator's station shall be provided.

(d) A boom hoist disconnect, shutoff, or hydraulic relief shall be provided to automatically stop the boom hoist when the boom reaches a predetermined high angle.

(e) A boom length indicator readable from the operator's station shall be provided for telescoping booms unless the load rating is independent of the boom length.

(f) Booms, boom sections, and jibs shall be identified and shall be used only for the purposes recommended by the manufacturer.

5-1.9.2 Exhaust Gases

Engine exhaust gases shall be piped to the outside of the cab and discharged in a direction away from the operator. All exhaust pipes shall be guarded or insulated to prevent contact with personnel when performing normal duties.

5-1.9.3 Outriggers

(a) Means shall be provided to hold all outriggers in the retracted position while traveling or in the extended position when set for operating.

(b) An indicator shall be provided at the operator's station(s) that allows the operator to visually determine if the horizontal outrigger beam positions coincide with the positions specified on the load rating chart.

(c) Power-actuated jacks, where used, shall be provided with the means (such as integral load hold check valves on hydraulic cylinders, mechanical locks, etc.) to prevent loss of support under load.

(d) Means shall be provided for fastening outrigger floats to the ends of the outriggers or jack cylinder rods when in use.

(e) *Partially Extended Outrigger Beams, Outrigger Beam Position*

(1) A device shall be provided that accurately locates the outrigger beam horizontal position(s) to coincide with the position(s) specified on the load rating chart.

(2) Visible indication of the manufacturer's specified outrigger beam horizontal positions shall be provided by means such as stripes painted on the outrigger beams.

5-1.9.4 Locomotive Crane Equipment

(a) *Truck Wedges or Jacks.* Locomotive crane cars shall be provided with removable wedges or jacks for transmitting loads from the crane body directly to the wheels without permitting the truck springs to function when handling heavy loads. These wedges shall be removable, or the jacks releasable, in a manner positive for transit.

(b) *Truck Center Pins.* Each truck center pin shall be provided with a connecting means, such as a king bolt, to permit truck weight to contribute to crane stability.

5-1.9.5 Welded Construction

All welding procedures and welding operator qualifications shall be in accordance with AWS D14.3/D14.3M when welding is to be performed on load-sustaining members. Where special steels or other materials are used, the manufacturer shall provide welding procedures.

5-1.9.6 Replacement Parts

Replacement parts shall be manufactured by using at least the same design factors of the parts they are intended to replace.

5-1.9.7 Guards for Moving Parts

(a) Exposed moving parts (e.g., gears, set screws, projecting keys, chains, chain sprockets, and reciprocating or rotating parts) that might constitute a hazard under normal operating conditions shall be guarded.

(b) Guards shall be fastened and shall be capable of supporting, without permanent distortion, the weight of a 200 lb (90 kg) person unless the guard is located where it is impossible for a person to step on it.

5-1.9.8 Clutch and Brake Protection

Dry friction brakes and clutches shall be protected against rain and other liquids such as oil and lubricants.

5-1.9.9 Hydraulic and Pneumatic Line Protection

Exposed lines subject to damage shall be protected insofar as it is practical.

5-1.9.10 Operational Aids

The crane and/or device manufacturer's instructions shall describe the purpose of the device. The crane and/or device manufacturer shall provide recommendations for continued operation or shutdown of the crane if operational aids are inoperative or malfunctioning. Without such recommendations and any prohibitions from the manufacturer against further operation, the requirements of [para. 5-3.2.1.2\(b\)](#) shall apply.

5-1.9.10.1 Two-Blocking Features

(a) Telescopic boom cranes shall be equipped with an anti-two-block device or a two-block damage prevention feature for all points of two-blocking (e.g., jibs, extensions).

(b) Lattice boom cranes shall be equipped with an anti-two-block device or a two-block warning feature that functions for all points of two-blocking.

5-1.9.10.2 Load Indicators, Rated Capacity Indicators, and Rated Capacity Limiters. All cranes with a maximum rated load capacity of 3 tons or more shall have a load indicator, rated capacity indicator, or rated capacity (load) limiter.

5-1.9.10.3 Boom Angle or Radius Indicator. See [para. 5-1.9.1\(c\)](#).

5-1.9.10.4 Boom Hoist Disconnect, Shutoff, or Hydraulic Relief. See [para. 5-1.9.1\(d\)](#).

5-1.9.10.5 Boom Length Indicator. See [para. 5-1.9.1\(e\)](#).

5-1.9.10.6 Crane Level Indicator. See [para. 5-1.9.12\(d\)](#).

5-1.9.10.7 Drum Rotation Indicator. See [para. 5-1.3.2\(a\)\(5\)](#).

5-1.9.11 Lubricating Points

Lubricating points should be accessible without the necessity of removing guards or other parts.

5-1.9.12 Miscellaneous Equipment

(a) The fuel tank filler pipe shall be located or protected so as not to allow spill or overflow to run onto the engine, exhaust, or electrical equipment of the machine being fueled.

(b) *Toolbox.* A metal receptacle should be secured to the crane for storing tools and lubricating equipment.

(c) An audible signal device shall be provided. The control for the device shall be within reach of the operator.

(d) Means shall be provided for the operator to visually determine the levelness of the crane.

(e) Hydraulic relief valves used to limit maximum pressure developed within the hydraulic system shall have pressure settings to permit operation under rated loading conditions and also to meet the requirements of [para. 5-1.3.1\(a\)](#).

(f) Means shall be provided for checking the manufacturer's specified pressure settings in each hydraulic circuit.

(g) Durable signs shall be installed at the operator's station and on the outside of the crane, warning that electrocution or serious bodily injury may occur, unless a minimum clearance of 10 ft (3 m) is maintained between energized lines (up to 50 kV) and the crane, load line, rigging, and load, and that greater clearances are required for higher voltages (refer to [Table 5-3.4.5.1-1](#)).

SECTION 5-1.10: STRUCTURAL PERFORMANCE

(a) Prototype booms, jibs, gantries, masts, outriggers, carrier frames, and upper frames of production models of rope-supported lattice boom cranes shall meet the performance requirements of SAE J987. On special designs (not production models) or specific lift situations, calculations that verify the equipment's ability to meet the performance requirements of SAE J987, done by the crane manufacturer or a qualified person, are acceptable.

(b) Prototype booms, jibs, masts, lattice extensions (jibs), outriggers, carrier frames, and upper frames of production models of telescopic cantilever boom cranes shall meet the performance requirements of SAE J1063. On special designs (not production models) or specific lift situations, calculations that verify the equipment's ability to meet the performance requirements of

SAE J1063, done by the crane manufacturer or a qualified person, are acceptable.

SECTION 5-1.11: CRANES USED FOR OTHER THAN LIFTING SERVICE

(a) When cranes within the scope of this Volume are used for service other than lifting service, the manufacturer or (when not available from the manufacturer) a qualified person shall establish the ratings, operating limitations, maintenance, testing, and inspection requirements that apply during that use. The manufacturer or qualified person shall consider, as minimum requirements, the maintenance, testing, and inspection requirements in [Chapter 5-2](#) and the conduct of operators provisions in [Section 5-3.1](#).

(b) Documentation supporting the ratings, operating limitations, maintenance, testing, and inspection requirements of (a) above shall be maintained.

SECTION 5-1.12: TRANSLATIONS OF SAFETY-RELATED INFORMATION AND CONTROL DESIGNATIONS

(a) *Translation of Non-English Documentation Into English*

(1) The wording of written non-English safety information and manuals regarding use, inspection, and maintenance shall be translated into English by using

professional translation industry standards, which include, but are not limited to, the following:

(-a) translation of the complete paragraph message, instead of word by word

(-b) grammatical accuracy

(-c) respectfulness of the source document content without omitting or expanding the text

(-d) accurate translation of the terminology

(-e) reflection of the level of sophistication of the original document

(2) The finished translation shall be verified for compliance with (1)(-a) through (1)(-e) above by a qualified person having an understanding of the technical content of the subject matter.

(3) Pictograms used to identify controls shall be described in the manuals. The pictograms should comply with ISO 7000, ISO 7296, or other recognized source, if previously defined. The text of the description shall meet the criteria of (1) and (2) above.

(b) Any non-English documentation provided in addition to English shall be translated and reviewed in accordance with the requirements listed in (a) above.

Chapter 5-2

Inspection, Testing, and Maintenance

(18) SECTION 5-2.1: INSPECTION — GENERAL

Inspections shall be performed by a designated person. Any deficiency identified shall be examined and a determination made by a qualified person as to whether it constitutes a hazard, and if so, what additional steps need to be taken to address the hazard.

(18) 5-2.1.1 Inspection Classification

(a) *Initial Inspection.* Prior to initial use, all new and altered cranes shall be inspected to verify compliance with the provisions of this Volume.

(b) *Regular Inspection.* The inspection procedure for cranes in regular service is divided into two general classifications based on the intervals at which inspections should be performed. The intervals depend on the nature of the critical components of the crane and the degree of their exposure to wear, deterioration, or malfunction. The two general classifications are herein designated as *frequent* and *periodic*, with respective intervals between inspections as defined below.

(1) *Frequent Inspection.* Daily to monthly intervals.

(2) *Periodic Inspection.* One- to 12-month intervals, or as specifically recommended by the manufacturer or a qualified person.

(18) 5-2.1.2 Frequent Inspection

Items such as the following shall be inspected for defects at intervals as defined in [para. 5-2.1.1\(b\)\(1\)](#) or as specifically indicated by the manufacturer, including observation during operation for any deficiencies that might appear between regular inspections. Any deficiencies shall be carefully examined and a determination made as to whether they constitute a hazard.

(a) all control mechanisms for maladjustment interfering with proper operation: daily, when used.

(b) all control mechanisms for excessive wear of components and contamination by lubricants or other foreign matter.

(c) structural members for damage or deformation. This inspection may be accomplished by observation from the ground without lowering the boom unless deficiencies are suspected.

(d) operational aids for malfunction: daily, when used.

(e) all hydraulic hoses, particularly those that flex in normal operation of crane functions, should be visually inspected once every working day, when used.

(f) hooks and latches for deformation, chemical damage, cracks, and wear (refer to ASME B30.10).

(g) rope reeving for compliance with crane manufacturer's specifications.

(h) electrical apparatus for malfunctioning, signs of excessive deterioration, dirt, and moisture accumulation.

(i) hydraulic system for proper oil level: daily, when used.

(j) tires for recommended inflation pressure.

5-2.1.3 Periodic Inspection

(18)

Complete inspections of the crane shall be performed at intervals as generally defined in [para. 5-2.1.1\(b\)\(2\)](#), depending on the crane's activity, severity of service, and environment, or as specifically indicated below. These inspections shall include the requirements of [para. 5-2.1.2](#) and items such as the following. Any deficiencies shall be examined and a determination made as to whether they constitute a hazard.

(a) deformed, cracked, or corroded members in the crane structure and entire boom

(b) loose bolts or rivets

(c) cracked or worn sheaves and drums

(d) worn, cracked, or distorted parts such as pins, bearings, shafts, gears, rollers, and locking devices

(e) excessive wear on brake and clutch system parts, linings, pawls, and ratchets

(f) any significant inaccuracies of operational aids [refer to [para. 5-2.1.6\(b\)](#)]

(g) lack of performance and compliance with safety requirements of gasoline, diesel, electric, or other power plants

(h) excessive wear of chain drive sprockets and excessive chain stretch

(i) cracked crane hooks

(j) malfunctioning travel steering, braking, and locking devices

(k) excessively worn or damaged tires

(l) hydraulic and pneumatic hose, fittings, and tubing
(1) evidence of leakage at the surface of the flexible hose or its junction with the metal and couplings.

(2) blistering or abnormal deformation of the outer covering of the hydraulic or pneumatic hose.

(3) leakage at threaded or clamped joints that cannot be eliminated by normal tightening or recommended procedures.

(4) evidence of excessive abrasion or scrubbing on the outer surface of a hose, rigid tube, or fitting. Means shall be taken to eliminate the interference of elements in contact or otherwise protect the components.

(m) hydraulic and pneumatic pumps and motors

- (1) loose bolts or fasteners
- (2) leaks at joints between sections
- (3) shaft seal leaks
- (4) unusual noises or vibration
- (5) loss of operating speed
- (6) excessive heating of the fluid
- (7) loss of pressure

(n) hydraulic and pneumatic valves

- (1) cracks in valve housing
- (2) improper return of spool to neutral position
- (3) leaks at spools or joints
- (4) sticking spools
- (5) failure of relief valves to attain correct pressure setting

(6) relief valve pressures as specified by the manufacturer

(o) hydraulic and pneumatic cylinders

- (1) drifting caused by fluid leaking across the piston
- (2) rod seals leakage
- (3) leaks at welded joints
- (4) scored, nicked, or dented cylinder rods
- (5) dented case (barrel)
- (6) loose or deformed rod eyes or connecting joints

(p) evidence of rubber particles on the hydraulic filter element, which may indicate hose, O-ring, or other rubber component deterioration. Metal chips or pieces on the filter may denote failure in pumps, motors, or cylinders. Further checking will be necessary to determine the origin of the problem before corrective action can be taken.

(18) 5-2.1.4 Cranes Not in Regular Use

(a) A crane that has been idle for a period of 1 month or more, but less than 6 months, shall be given an inspection conforming with the requirements of [paras. 5-2.1.2](#) and [5-2.4.2\(a\)](#) before being placed in service.

(b) A crane that has been idle for a period of over 6 months shall be given a complete inspection conforming with the requirements of [paras. 5-2.1.2](#), [5-2.1.3](#), and [5-2.4.2](#) before being placed in service.

(c) Standby cranes shall be inspected at least semiannually in accordance with the requirements of [paras. 5-2.1.2](#) and [5-2.4.2\(a\)](#). Cranes that are exposed to adverse environmental conditions should be inspected more frequently.

5-2.1.5 Inspection Records

(18)

(a) Dated records for periodic inspections shall be made on critical items such as brakes, crane hooks, ropes, and hydraulic and pneumatic relief pressure valves. Records should be kept where they are available.

(b) A crane log specific to the individual crane should be kept available in each crane. The crane log should contain, at a minimum, dated records of deficiencies or irregularities as determined by inspections and operation.

5-2.1.6 Operational Aids

(18)

(a) Prior to daily operation, operational aids shall be checked in accordance with the device/crane manufacturer's recommended procedures to determine if they are functioning properly.

(b) Operational aids shall be inspected and tested in accordance with the device/crane manufacturer's recommended procedures as part of the periodic inspection of [para. 5-2.1.3](#).

(c) When operational aids are inoperative or malfunctioning, the crane and/or device manufacturer's recommendations for continued operation or shutdown of the crane shall be followed until the problems are corrected [refer to [para. 5-3.2.1.2\(b\)\(1\)](#)]. Without such recommendations and any prohibitions from the manufacturer against further operation, the requirements of [para. 5-3.2.1.2\(b\)](#) shall apply.

SECTION 5-2.2: TESTING

5-2.2.1 Operational Tests

(a) Each new production crane shall be tested by the manufacturer to the extent necessary to ensure compliance with the operational requirements of this Section. Testing shall include, but is not limited to, the following:

- (1) load lifting and lowering mechanisms
- (2) boom lifting and lowering mechanisms
- (3) boom extension and retraction mechanism
- (4) swinging mechanism
- (5) travel mechanism
- (6) operational aids

(b) Where the complete production crane is not supplied by one manufacturer, such tests shall be conducted at final assembly.

(c) Operational crane test results shall be made available.

5-2.2.2 Load Testing

(a) Test loads shall not exceed load ratings established by the manufacturer unless approved in writing by the manufacturer or a qualified person. If required, operational aids that function to restrict the capacity of the crane may be temporarily overridden to handle the test load during the performance of the test.

(b) *Cranes With Altered, Repaired, or Replaced Parts.* Prior to initial use, all cranes in which load-sustaining parts have been altered, replaced, or repaired should be load tested by, or under the direction of, a qualified person who shall determine that the altered, replaced, or repaired parts are adequately tested.

(1) The replacement of the rope is specifically excluded from this requirement. However, a functional test of the crane under a normal operating load should be made prior to putting the crane back in service.

(2) Written reports that show test procedures and confirm the adequacy of repairs or alterations shall be furnished by a designated person.

(c) Where rerating is necessary

(1) no crane shall be rerated in excess of the original load ratings unless such rating changes are approved by the crane manufacturer or a qualified person

(2) any crane being rerated in excess of the original load ratings shall be tested under the direction of the crane manufacturer or a qualified person to confirm compliance with the requirements of [para. 5-1.1.1\(d\)](#) and [Section 5-1.10](#)

SECTION 5-2.3: MAINTENANCE

5-2.3.1 Preventive Maintenance

(a) A preventive maintenance program shall be established and should be based on the recommendations outlined in the crane manufacturer's manual. If a qualified person determines it is appropriate, the program should also include that individual's additional recommendations based on a review of the crane application and operations. Dated records should be placed on file.

(b) It is recommended that replacement parts be obtained from the original equipment manufacturer.

5-2.3.2 Maintenance Procedure

(a) Before adjustments and repairs are started on a crane, the following precautions shall be taken, as applicable:

(1) Place the crane where it will cause the least interference with other equipment or operations in the area.

(2) Set all controls in the off position and ensure that all operating features are secured from inadvertent motion by brakes, pawls, or other means.

(3) Render the starting means inoperative.

(4) Stop the power plant or disconnect at power takeoff.

(5) Lower the boom to the ground, if possible, or otherwise secure it against dropping.

(6) Lower the lower load block to the ground or otherwise secure it against dropping.

(7) Relieve hydraulic oil pressure from all hydraulic circuits before loosening or removing hydraulic components.

(b) "Warning" or "Out of Order" signs shall be placed on the crane controls. For locomotive cranes, blue flag protection shall be employed. Signs or flags shall be removed only by authorized personnel.

(c) After adjustments and repairs have been made, the crane shall not be returned to service until all guards have been reinstalled, trapped air is removed from the hydraulic system, deactivated devices or systems are restored to operating condition, and maintenance equipment is removed.

5-2.3.3 Adjustments and Repairs

(a) Any hazardous conditions disclosed by the inspection requirements of [Section 5-2.1](#) shall be corrected before operation of the crane is resumed. Adjustments and repairs shall be done only by designated personnel.

(b) Adjustments shall be made within the manufacturer's specified tolerances to maintain correct functioning of components. The following are examples:

(1) functional operating mechanisms

(2) operational aids

(3) pneumatic, electronic, hydraulic, and mechanical control systems

(4) power plants

(5) braking systems

(c) Repairs or replacements shall be provided as needed for operation. The following are examples:

(1) critical parts of functional operating mechanisms that are cracked, broken, corroded, bent, or excessively worn.

(2) critical parts of the crane structure that are cracked, bent, broken, or excessively corroded.

(3) damaged or worn hooks as described under "Maintenance" in ASME B30.10. Repairs by welding or reshaping are not recommended.

(d) Repairs shall be made according to the manufacturer's instructions if instructions are available. Absent instructions from the manufacturer, repairs shall be made according to the directions of a qualified person.

(e) Repairs shall return the crane to a condition of structural, mechanical, and functional integrity to permit operation of the crane in accordance with the manufacturer's published performance specifications.

(f) Instructions shall be provided by the manufacturer for the removal of air from hydraulic circuits.

5-2.3.4 Lubrication

(a) All moving parts of the crane for which lubrication is specified should be regularly lubricated. Lubricating systems should be checked for proper delivery of lubricant. Care should be taken to follow the manufacturer's recommendations as to the points and frequency of lubrication, maintenance of lubricant levels, and types of lubricant to be used.

Figure 5-2.4.2-1 Core Failure in 19 × 7 Rotation-Resistant Rope

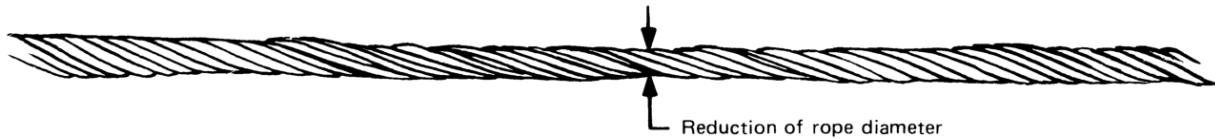

GENERAL NOTE: Notice the lengthening of lay and reduction of diameter.

(b) Machinery shall be stationary while lubricants are being applied and protection provided as called for in paras. 5-2.3.2(a)(2) through 5-2.3.2(a)(5), unless equipped for automatic or remote lubrication.

SECTION 5-2.4: ROPE INSPECTION, REPLACEMENT, AND MAINTENANCE

(18) 5-2.4.1 General

(a) Due to crane design configuration to maintain mobility, sheave diameters, drum diameters, and rope design factors are limited. Because of these limited design parameters, inspection to detect deterioration in accordance with para. 5-2.4.2 and timely replacement in accordance with para. 5-2.4.3 are essential. The information listed in para. 5-1.1.4(b) should be reviewed prior to periodic inspection to determine if the ropes currently installed on the crane correspond to the records.

(b) All inspections shall be performed by a designated person. Any deficiencies identified shall be examined and a determination made by a qualified person as to whether they constitute a hazard, and if so what additional steps need to be taken to address the hazard.

(18) 5-2.4.2 Inspection

(a) Frequent Inspection

(1) All running ropes in service should be visually inspected once each working day. A visual inspection shall consist of observation of all rope that can reasonably be expected to be in use during the day's operations. These visual observations should be concerned with discovering gross damage that may be an immediate hazard, including the following:

(-a) distortion of the rope such as kinking, crushing, unstranding, birdcaging, main strand displacement, or core protrusion. Loss of rope diameter in a short rope length or unevenness of outer strands should provide evidence that the rope or ropes must be replaced.

(-b) general corrosion.

(-c) broken or cut strands.

(-d) number, distribution, and type of visible broken wires [see paras. 5-2.4.3(b)(1), 5-2.4.3(b)(2), and 5-2.4.3(b)(7) for further guidance].

(-e) internal wear or broken wires for ropes operating on synthetic sheaves. Common indicators of internal deterioration include localized reduction in rope diameter, corrosion between the strands, localized lengthening of rope lay, wire displacement, or wire distortion.

(-f) core failure in rotation-resistant ropes (see Figure 5-2.4.2-1). When such damage is discovered, the rope shall either be removed from service or given an inspection as detailed in (b) below.

(2) Care shall be taken when inspecting sections of rapid deterioration such as flange points, crossover points, and repetitive pickup points on drums.

(3) Care shall be taken when inspecting certain ropes such as the following:

(-a) rotation-resistant ropes, because of their higher susceptibility to damage and increased deterioration when working on equipment with limited design parameters. The internal deterioration of rotation-resistant ropes may not be readily observable.

(-b) boom hoist ropes, because of the difficulties of inspection and the important nature of these ropes.

(b) Periodic Inspection

(1) The inspection frequency shall be determined by a qualified person and shall be based on such factors as expected rope life as determined by experience on the particular installation or similar installations, severity of environment, percentage of capacity lifts, frequency rates of operation, and exposure to shock loads. Inspections need not be at equal calendar intervals and should be more frequent as the rope approaches the end of its useful life. This inspection shall be performed at least annually.

(2) Periodic inspections shall cover the entire length of the rope. Only the surface wires of the rope need be inspected. No attempt should be made to open the rope. Any deterioration resulting in an appreciable loss of original strength, such as the conditions described below, shall be noted and a determination made as to whether further use of the rope would constitute a hazard.

(-a) points listed in (a) above

(-b) reduction of rope diameter below nominal diameter due to loss of core support, internal or external corrosion, or wear of outside wires

(-c) severely corroded or broken wires at end connections

(-d) severely corroded, cracked, bent, worn, or improperly applied end connections

(3) Care shall be taken when inspecting sections of rapid deterioration, such as the following:

(-a) sections in contact with saddles, equalizer sheaves, or other sheaves where rope travel is limited

(-b) sections of the rope at or near terminal ends where corroded or broken wires may protrude

(18) 5-2.4.3 Rope Replacement

(a) No precise rules can be given for determination of the exact time for rope replacement since many variable factors are involved. Once a rope reaches any one of the specified removal criteria, it may be allowed to operate to the end of the work shift, based on the judgment of a qualified person. The rope shall be replaced after that work shift, at the end of the day, or at the latest time prior to the equipment being used by the next work shift.

(b) Removal criteria for rope replacement shall be as follows:

(1) Broken Wires

(-a) in running ropes, six randomly distributed broken wires in one lay or three broken wires in one strand in one lay.

(-b) in rotation-resistant ropes, two randomly distributed broken wires in six rope diameters or four randomly distributed broken wires in 30 rope diameters. For special conditions relating to rotation-resistant rope, refer to [para. 5-3.2.1.1\(e\)\(1\)\(-b\)](#).

(2) one outer wire broken at the point of contact with the core of the rope that has worked its way out of the rope structure and protrudes or loops out from the rope structure. Additional inspection of this section is required.

(3) independent wire rope core (IWRC) or strand core protrusion between the outer strands.

(4) kinking, crushing, birdcaging, or any other damage resulting in distortion of the rope structure.

(5) apparent damage from any heat source, including, but not limited to, welding, power line strikes, or lightning.

(6) reduction from nominal diameter of more than 5%.

(7) in standing ropes, three or more broken wires in one rope lay anywhere in the wire rope or two or more broken wires at end connections.

(8) severe corrosion as evidenced by pitting.

(9) deviation shall be allowed from the removal criteria listed in (1) through (8) above only with written approval of the manufacturer of the specific wire rope.

(c) Broken wire removal criteria cited in this Volume applies to wire rope operating on multilayer drums regardless of sheave material.

(d) The design factor for replacement wire rope shall be in accordance with [para. 5-1.7.1](#).

(e) Replacement ropes shall meet the diameter and specifications shown on the load rating chart and shall meet or exceed the minimum breaking force shown, unless deviations are approved by the crane manufacturer, rope manufacturer, or a qualified person.

(f) If load hoist ropes installed on a crane deviate from the crane manufacturer's recommendations shown on the load rating chart, the following shall apply:

(1) The load ratings and allowable line pull shown on the load rating chart shall not be exceeded.

(2) If changes to the reeving specifications and/or a reduction in load ratings is necessary, these changes shall be approved by the crane manufacturer or a qualified person. Prior to lift operations, the changes shall be durably noted and maintained with the load rating chart.

(g) When replacement wire ropes are installed on a crane, the requirements of [para. 5-1.1.4\(b\)](#) shall be followed. The date of installation shall be noted.

(h) *Ropes Not in Regular Use*. All rope that has been idle for a period of a month or more due to shutdown or storage of a crane on which it is installed shall be given an inspection in accordance with [para. 5-2.4.2\(b\)](#) before it is placed in service. This inspection shall be for all types of deterioration and shall be performed in accordance with [para. 5-2.4.1\(b\)](#).

(i) Inspection Records

(1) *Frequent Inspection*. No records required.

(2) *Periodic Inspection*. To establish data as a basis for judging the proper time for replacement, a dated report of rope condition at each periodic inspection shall be kept on file. This report shall cover points of deterioration listed in [para. 5-2.4.2\(b\)\(2\)](#). If the rope is replaced, only that part need be recorded.

(j) A long-range inspection program should be established and should include records on the examination of ropes removed from service so that a relationship can be established between visual observation and actual condition of the internal structure.

5-2.4.4 Rope Maintenance

(a) Rope should be stored to prevent damage or deterioration.

(b) Unreeling or uncoiling of rope shall be done as recommended by the rope manufacturer and with care to avoid kinking or inducing a twist.

(c) Prior to cutting a wire rope, seizings shall be placed on each side of the point to be cut. The minimum length of each seizing shall be equal to or exceed the nominal diameter of the wire rope to which it is being applied. Seizing may consist of wire, strand, tape, or other material as long as the seizing holds the wires and strands firmly in place during the rope's cutting and handling. The required number of seizings is as follows:

(1) on preformed wire rope, one seizing on each side of the point to be cut

(2) on nonpreformed wire rope, at least three seizings on each side of the wire rope to be cut

(d) During installation, care should be exercised to avoid dragging of the rope in dirt or around objects that will scrape, nick, crush, or induce sharp bends in it.

(e) Rope should be maintained in a well-lubricated condition. It is important that lubricant applied as part of a maintenance program shall be compatible with the original lubricant, and to this end, the rope manufacturer should be consulted; lubricant applied shall be of the type that does not hinder visual inspection. Those sections of

rope that are located over sheaves or are otherwise hidden during inspection and maintenance procedures require special attention when lubricating rope. The object of rope lubrication is to reduce internal friction and to prevent corrosion.

(f) When an operating rope shows greater wear at well-defined localized areas than on the remainder of the rope, rope life can be extended (in cases where a reduced rope length is adequate) by cutting off a section at the worn end, and thus shifting the wear to different areas of the rope.

Chapter 5-3 Operation

SECTION 5-3.1: QUALIFICATIONS AND RESPONSIBILITIES

5-3.1.1 Operators

(a) Cranes shall be operated only by the following personnel:

(1) those who have met the requirements of [paras. 5-3.1.2\(a\) through 5-3.1.2\(c\)](#) and [5-3.1.2\(f\)](#).

(2) those who have met the requirements of [para. 5-3.1.2\(d\)](#) and who are training for the type of crane being operated. While operating the crane, trainees shall be under the supervision of a designated person. The number of trainees permitted to be supervised by a single designated person, the physical location of the designated person while supervising, and the type of communication required between the designated person and the trainee shall be determined by a qualified person.

(3) maintenance personnel who have completed all operator trainee qualification requirements. Operation by these persons shall be limited to those crane functions necessary to perform maintenance on the crane or to verify the performance of the crane after maintenance has been performed.

(4) inspectors who have completed all operator trainee qualification requirements. Operation by these persons shall be limited to those crane functions necessary to accomplish the inspection.

(b) Only the personnel specified in (a) above, oilers, supervisors, and those specific persons authorized by supervisors shall enter a crane cab. Persons shall only enter the cab when their duties require them to do so, and then only with the knowledge of the operator or other appointed persons.

5-3.1.2 Qualifications for Operators

Operators shall be required to successfully meet the qualifications for the specific type of crane (see [Figures 5-0.2.1-1 through 5-0.2.1-10](#)) that they are operating.

(a) Operator and operator trainees shall meet the following physical qualifications unless it can be shown that failure to meet the qualifications will not affect the operation of the crane. In such cases, specialized clinical or medical judgments and tests may be required.

(1) vision of at least 20/30 Snellen in one eye and 20/50 in the other, with or without corrective lenses.

(2) ability to distinguish colors, regardless of position, if color differentiation is required.

(3) adequate hearing to meet operational demands, with or without hearing aid.

(4) sufficient strength, endurance, agility, coordination, and speed of reaction to meet the operation demands.

(5) normal depth perception, field of vision, reaction time, manual dexterity, coordination, and no tendencies to dizziness or similar undesirable characteristics.

(6) a negative result for a substance abuse test. The level of testing will be determined by the standard practice for the industry where the crane is employed and this test shall be confirmed by a recognized laboratory service.

(7) no evidence of having physical defects or emotional instability that could render a hazard to the operator or others, or that in the opinion of the examiner could interfere with the operator's performance. If evidence of this nature is found, it may be sufficient cause for disqualification.

(8) no evidence of being subject to seizures or loss of physical control; such evidence shall be sufficient reason for disqualification. Specialized medical tests may be required to determine these conditions.

(b) Operator requirements shall include, but not be limited to, the following:

(1) evidence of successfully passing a physical examination as defined in (a) above.

(2) satisfactory completion of a written examination covering operational characteristics, controls, and emergency control skills, such as response to fire, power line contact, loss of stability, or control malfunction, as well as characteristic and performance questions appropriate to the crane type for which qualification is being sought.

(3) demonstrated ability to read, write, comprehend, and use arithmetic and a load rating chart, in the language of the crane manufacturer's operation and maintenance instruction materials.

(4) satisfactory completion of a combination written and verbal test on load rating chart usage that covers a selection of the configurations (the crane may be equipped to handle) for the crane type for which qualification is being sought.

(5) satisfactory completion of an operation test demonstrating proficiency in performing lifting, lowering, booming, telescoping, and swinging functions at various radii as well as shutdown. Testing shall also include proficiency in prestart and poststart inspection, securing procedures, and traveling by appropriate written, oral, or practical methods.

(6) demonstrated understanding of the applicable sections of the B30 Standard and federal, state, and local requirements.

(c) Operators who have successfully qualified for a specific crane type shall be required to be requalified if supervision deems it necessary. Requalification shall include, but not be limited to, the following:

(1) evidence of successfully passing a current physical examination as defined in (a) above

(2) satisfactory completion of a written examination covering operational characteristics, controls, and emergency control skills, such as response to fire, power line contact, loss of stability, or control malfunction, as well as characteristic and performance stability questions appropriate to the crane type for which requalification is being sought

(3) demonstrated ability to read, write, comprehend, and use arithmetic and a load rating chart, in the language of the crane manufacturer's operation and maintenance instruction materials

(4) satisfactory completion of a combination written and verbal test on load rating chart usage that covers a selection of the configurations (the crane may be equipped to handle) for the crane type for which requalification is being sought

(5) satisfactory completion of an operation test demonstrating proficiency in handling the specific crane type for which requalification is being sought, including both prestart and poststart inspections, maneuvering skills, shutdown, and securing procedures

(6) demonstrated understanding of the applicable sections of the B30 Standard and federal, state, and local safety requirements

(d) Trainee qualification requirements shall include, but not be limited to, the following:

(1) evidence of successfully passing a current physical examination as defined in (a) above

(2) satisfactory completion of a written examination covering safety, operational characteristics and limitations, and controls of the crane type for which qualification is being sought

(3) demonstrated ability to read, write, comprehend, and use arithmetic and a load rating chart, in the language of the crane manufacturer's operation and maintenance instruction materials

(4) satisfactory completion of a combination written and verbal test on load rating chart usage covering various crane configurations

(e) Trainee qualification, operator qualification, and operator requalification shall be performed by a designated person who, by experience and training, fulfills the requirements of a qualified person.

(f) Operator physical examinations shall be required every 3 yr as defined in (a) above, or more frequently if supervision deems it necessary.

5-3.1.3 Responsibilities

(18)

While the organizational structure of various projects may differ, the following roles are described here for purposes of delineating responsibilities. All responsibilities listed below shall be assigned in the worksite organization. (A single individual may perform one or more of these roles.)

(a) *Crane Owner*. The crane owner has custodial control of a crane by virtue of lease or ownership.

(b) *Crane User*. The crane user arranges the crane's presence on a worksite and controls its use there.

(c) *Site Supervisor*. The site supervisor exercises supervisory control over the worksite on which a crane is being used and over the work that is being performed on that site.

(d) *Lift Director*. The lift director directly oversees the work being performed by a crane and the associated rigging crew.

(e) *Crane Operator*. The crane operator directly controls the crane's functions.

(f) *Rigger*. The rigger selects, configures, and assembles the rigging equipment for attachment, support, control, and detachment of the load during lifting activities.

5-3.1.3.1 Responsibilities of the Crane Owner and Crane User. In some situations the owner and the user may be the same entity and is therefore accountable for all of the following responsibilities. In other cases, the user may lease or rent a crane from the owner without supervisory, operational, maintenance, or support personnel or services from the owner. In these situations, [paras. 5-3.1.3.1.1](#) and [5-3.1.3.1.2](#) shall apply.

5-3.1.3.1.1 Crane Owner. The crane owner's responsibilities shall include the following:

(a) providing a crane that meets the requirements of [Chapters 5-1](#) and [5-2](#) as well as specific job requirements defined by the user

(b) providing a crane and all necessary components, specified by the manufacturer, that meets the user's requested configuration and capacity

(c) providing all applicable load rating chart(s) and diagrams

(d) providing additional technical information pertaining to the crane, necessary for crane operation, when requested by the crane user

(e) providing field assembly, disassembly, operation, maintenance information, and warning decals and placards installed as prescribed by the crane manufacturer

(f) establishing an inspection, testing, and maintenance program in accordance with [Chapter 5-2](#) and informing the crane user of the requirements of this program

(g) designating personnel in accordance with [Section 5-0.3](#) for the purpose of maintenance, repair, transport, assembly, and disassembly

(h) designating personnel in accordance with [Section 5-0.3](#) for inspections as required in [Section 5-2.1](#)

(i) maintaining the rope information listed in [para. 5-1.1.4\(b\)](#) for the rope currently installed on each drum

(k) informing the crane owner if any rope on the crane is replaced or shortened. If a rope is replaced, the wire rope information listed in [para. 5-1.1.4\(b\)](#) shall be provided as well as the date of replacement.

5-3.1.3.2 Responsibilities of Site Supervisor and Lift Director. In some situations, the site supervisor and the lift director may be the same person.

5-3.1.3.2.1 Site Supervisor. The site supervisor's (18) responsibilities shall include the following:

(a) ensuring that the crane meets the requirements of [Chapter 5-2](#) prior to initial site usage.

(b) determining if additional regulations are applicable to crane operations.

(c) ensuring that a qualified person is designated as the lift director.

(d) ensuring that crane operations are coordinated with other jobsite activities that will be affected by or will affect lift operations.

(e) ensuring that the area for the crane is adequately prepared. The preparation includes, but is not limited to, the following:

(1) access roads for the crane and associated equipment

(2) sufficient room to assemble and disassemble the crane

(3) an operating area that is suitable for the crane with respect to levelness, surface conditions, support capability, proximity to power lines, excavations, slopes, underground utilities, subsurface construction, and obstructions to crane operation

(4) traffic control as necessary to restrict unauthorized access to the crane's working area

(f) ensuring that work involving the assembly and disassembly of a crane is supervised by a qualified person.

(g) ensuring that crane operators meet the requirements of [para. 5-3.1.2](#).

(h) ensuring that conditions that may adversely affect crane operations are addressed. Such conditions include, but are not limited to, the following:

(1) poor soil conditions

(2) wind velocity or gusting winds

(3) heavy rain

(4) fog

(5) extreme cold

(6) artificial lighting

(i) allowing crane operation near electric power lines only when the requirements of [para. 5-3.4.5](#) have been met.

(j) permitting special lifting operations only when equipment and procedures required by this Volume, the crane manufacturer, or a qualified person are employed. Such operations include, but are not limited to, the following:

(1) multiple crane lifts

(2) lifting personnel

(18) **5-3.1.3.1.2 Crane User.** The crane user's responsibilities shall include the following:

(a) complying with the requirements of this Volume, manufacturer's requirements, and those regulations applicable at the worksite.

(b) using supervisors for crane activities that meet the requirements for a qualified person as defined in [para. 5-0.2.2](#).

(c) ensuring that the crane is in proper operating condition prior to initial use at the worksite by

(1) verifying that the crane owner has provided documentation that the crane meets the requirements of [para. 5-2.1.5](#)

(2) verifying that a frequent inspection has been performed as defined in [para. 5-2.1.2](#)

(d) verifying that the crane has the necessary lifting capacity to perform the proposed lifting operations in the planned configuration. Load rating charts may be temporarily removed from the crane for lift planning or other purposes, provided the charts are replaced in the manufacturer's designated location before operating the crane.

(e) using crane operators that meet the requirements of [paras. 5-3.1.1](#) and [5-3.1.2\(f\)](#) and are qualified to perform the tasks that will be required with the crane that they are assigned to operate.

(f) ensuring the assigned operator(s) have been notified of adjustments or repairs that have not yet been completed, prior to commencing crane operations.

(g) designating personnel in accordance with [Section 5-0.3](#) for the purpose of maintenance, repair, transport, assembly, disassembly, and supervising lifting activities.

(h) designating personnel in accordance with [Section 5-0.3](#) for inspections as required in [Section 5-2.1](#).

(i) ensuring that all personnel involved in lifting activities, maintenance, repair, transport, assembly, disassembly, and inspection are aware of their responsibilities, assigned duties, and the associated hazards.

(j) ensuring that the inspection, testing, and maintenance programs specified by the crane owner are followed.

(3) pick and carry operations

(4) multiple load line use

(k) ensuring that work performed by a rigger(s) is supervised by a qualified person.

(l) ensuring that crane maintenance is performed by personnel that meet the competence requirements in [Section 5-0.3](#).

(18) **5-3.1.3.2.2 Lift Director.** The lift director's responsibilities shall include the following:

(a) being present at the jobsite during lifting operations.

(b) stopping crane operations if alerted to an unsafe condition affecting those operations.

(c) ensuring that the preparation of the area needed to support crane operations has been completed before crane operations commence.

(d) ensuring necessary traffic controls are in place to restrict unauthorized access to the crane's work area.

(e) ensuring that personnel involved in crane operations understand their responsibilities, assigned duties, and the associated hazards.

(f) addressing safety concerns raised by the operator or other personnel and being responsible if the lift director decides to overrule those concerns and directs crane operations to continue. (In all cases, the manufacturer's criteria for safe operation and the requirements of this Volume shall be adhered to.)

(g) appointing the signalperson(s) and conveying that information to the crane operator.

(h) ensuring that signalperson(s) appointed meet the requirements of [Section 5-3.3](#).

(i) allowing crane operation near electric power lines only when the requirements of [para. 5-3.4.5](#) and any additional requirements determined by the site supervisor have been met.

(j) ensuring that precautions are implemented when hazards associated with special lifting operations are present. Such operations include, but are not limited to, the following:

(1) multiple crane lifts

(2) lifting personnel

(3) pick and carry operations

(4) mobile cranes operating on barges

(5) multiple load line use

(k) ensuring that the applicable requirements of ASME B30.23 are met when lifting personnel.

(l) informing the crane operator of the weight of loads to be lifted, as well as the lifting, moving, and placing locations for these loads.

(m) obtaining the crane operator's verification that this weight does not exceed the crane's rated capacity.

(n) ensuring that a crane's load rigging is performed by a rigger(s) that meets the competence requirements in [Section 5-0.3](#).

5-3.1.3.3 Responsibilities of Crane Operators. The operator shall be responsible for the following listed items. The operator shall not be responsible for hazards or conditions that are not under his direct control and that adversely affect the lift operations. Whenever the operator has doubt as to the safety of crane operations, the operator shall stop the crane's functions in a controlled manner. Lift operations shall resume only after safety concerns have been addressed or the continuation of crane operations is directed by the lift director.

5-3.1.3.3.1 Crane Operator. The operator's responsibilities shall include the following: (18)

(a) reviewing the requirements for the crane with the lift director before operations.

(b) knowing what types of site conditions could adversely affect the operation of the crane and consulting with the lift director concerning the possible presence of those conditions.

(c) understanding and applying the information contained in the crane manufacturer's operating manual.

(d) understanding the crane's functions and limitations as well as its particular operating characteristics.

(e) using the crane's load rating chart(s) and diagrams and applying all notes and warnings related to the charts to confirm the correct crane configuration to suit the load, site, and lift conditions. Load rating chart(s) may be temporarily removed from the crane for lift planning or other purposes, provided the charts are replaced in the manufacturer's designated location before operating the crane.

(f) refusing to operate the crane when any portion of the load or crane would enter the prohibited zone of energized power lines except as defined in [para. 5-3.4.5.4](#).

(g) performing a daily inspection as specified in [paras. 5-2.1.2\(a\), 5-2.1.2\(c\) through 5-2.1.2\(f\), 5-2.1.2\(i\), and 5-2.4.2\(a\)\(1\)](#).

(h) promptly reporting the need for any adjustments or repairs to a designated person.

(i) following applicable lock out/tag out procedures.

(j) not operating the crane when physically or mentally unfit.

(k) ensuring that all controls are in the off or neutral position and that all personnel are in the clear before energizing the crane or starting the engine.

(l) not engaging in any practice that will divert the crane operator's attention while actually operating the crane controls.

(m) testing the crane function controls that will be used and operating the crane only if those function controls respond properly.

(n) operating the crane's functions, under normal operating conditions, in a smooth and controlled manner.

(o) knowing and following the procedures specified by the manufacturer or approved by a qualified person, for assembly, disassembly, setting up, and reeving the crane.

(p) knowing how to travel the crane.

(q) wearing the seat belt during transit or travel if the crane is so equipped.

(r) observing each outrigger during extension, setting, and retraction or using a signalperson to observe each outrigger during extension, setting, or retraction.

(s) ensuring that the load and rigging weight(s) have been provided.

(t) calculating or determining the net capacity for all configurations that will be used and verifying, using the load rating chart(s), that the crane has sufficient net capacity for the proposed lift.

(u) considering all factors known that might affect the crane capacity and informing the lift director of the need to make appropriate adjustments.

(v) knowing the standard and special signals as specified in [Section 5-3.3](#) and responding to such signals from the person who is directing the lift or an appointed signalperson. (When a signalperson is not required as part of the lift operation, the operator is then responsible for the movement of the crane. However, the operator shall obey a stop signal at all times, no matter who gives it.)

(w) understanding basic load rigging procedures. For responsibility of rigging the load and ensuring that the load is rigged properly, see [paras. 5-3.1.3.2.2\(n\)](#) and [5-3.1.3.4](#).

(x) if power fails during operations

(1) setting all brakes and locking devices

(2) moving all clutches or other power controls to the off or neutral position

(3) landing any load suspended below the hook under brake control if practical

(y) before leaving the crane unattended

(1) landing any load suspended below the hook, unless the requirements of [para. 5-3.2.1.4\(d\)](#) are met.

(2) disengaging the master clutch.

(3) setting travel, swing, boom brakes, and other locking devices.

(4) putting controls in the off or neutral position.

(5) stopping the engine. An exception to this may exist when crane operation is frequently interrupted during a shift and the operator must leave the crane. Under these circumstances, the engine may remain running and (1) through (4) above shall apply. The operator shall be situated where any entry to the crane can be observed.

(6) considering the recommendations of the manufacturer for securing the crane, when a local weather storm warning exists.

(18) **5-3.1.3.4 Responsibilities of the Rigger.** Riggers assigned to a load-handling activity shall, at a minimum, be responsible for the following:

(a) ensuring the weight of the load and its approximate center of gravity have been obtained.

(b) selecting the proper rigging equipment, inspecting it, and complying with the applicable operating practices according to the criteria of the applicable ASME B30 Volume (i.e., B30.9, B30.10, B30.20, B30.23, or B30.26).

(c) ensuring the rated load of the rigging equipment as selected and configured is sufficient for the load to be handled, based on the number of legs, hitch configuration, and effects of angles.

(d) properly attaching the rigging equipment to the hook, shackle, or other load-handling device.

(e) ensuring that rigging equipment is adequately protected from abrasion, cutting, or other damage during load-handling activities.

(f) rigging the load in a manner to ensure balance and stability during the load-handling activity.

(g) knowing and understanding the applicable signals for equipment in use.

(h) installing and using a tag line(s) when additional load control is required.

SECTION 5-3.2: OPERATING PRACTICES

5-3.2.1 Handling the Load

5-3.2.1.1 Size of Load

(a) No crane shall be loaded beyond the specifications of the load rating chart, except for test purposes as provided in [Section 5-2.2](#).

(b) The load to be lifted shall be within the rated capacity of the crane in its existing configuration [refer to [para. 5-1.1.1\(e\)](#)].

(c) If an outrigger(s) or portion of a crawler lifts free of its supporting surface while lifting within the limits of the specified load rating chart, refer to the instructions provided by the manufacturer for continued operation. If a liftoff condition is not addressed by the manufacturer's instructions, stop operation and consult the manufacturer or a qualified person for guidance.

(d) When loads that are not accurately known are to be lifted, the designated person responsible for supervising the lifting operations shall ascertain that the weight of the load does not exceed the crane ratings at the maximum radius at which the load is to be handled.

(e) When rotation-resistant ropes are used for load hoisting with an operating design factor less than 5, but in no case less than 3.5, the following special provisions shall apply:

(1) For each such lifting assignment

(-a) an appointed person shall direct each lift

(-b) a qualified person shall ascertain that the rope is in satisfactory condition [[paras. 5-2.4.2\(a\)\(1\)\(-a\)](#) through [5-2.4.2\(a\)\(1\)\(-e\)](#)] both before and after lifting; more than one broken wire in any one lay shall be sufficient reason to consider not using the rope for such lifts

(-c) operations shall be conducted in such a manner and at such speeds as to minimize dynamic effects

(2) Each lift under these provisions shall be recorded in the crane inspection record and such prior uses shall be considered before permitting another such lift.

(3) These provisions are not intended to permit duty cycle or repetitive lifts to be made with operating design factors less than 5.

5-3.2.1.2 Operational Aids

(a) In all cases, verified weights, measured radii, and manufacturer's load rating chart capacities and instructions shall take precedence over operational aids when handling a load. If it is necessary to temporarily override an operational aid to handle a rated capacity load within the limits established by the manufacturer's load capacity chart and instructions, the user shall comply with [paras. 5-3.2.1.1\(a\)](#) through [5-3.2.1.1\(d\)](#).

(b) When operational aids are inoperative or malfunctioning, the crane and/or device manufacturer's recommendations for continued operation or shutdown of the crane shall be followed until the problems are corrected. Without such recommendations and any prohibitions from the manufacturer against further operation, the following requirements shall apply:

(1) Recalibration or repair of the operational aid shall be accomplished as soon as is reasonably possible, as determined by a qualified person.

(2) When a load indicator, rated capacity indicator, or rated capacity limiter is inoperative or malfunctioning, the designated person responsible for supervising the lifting operations shall establish procedures for determining load weights and for conducting the lifts in accordance with [paras. 5-3.2.1.1\(a\)](#) through [5-3.2.1.1\(d\)](#).

(3) When a boom angle or radius indicator is inoperative or malfunctioning, radii or boom angle shall be determined by measurement.

(4) When an anti-two-block device, two-block damage prevention device, or two-block warning device is inoperative or malfunctioning, the designated person responsible for supervising the lifting operations shall establish procedures, such as assigning an additional signalperson, to furnish equivalent protection. This does not apply when lifting personnel. Personnel shall not be lifted when two-block devices are not functioning properly.

(5) When a boom length indicator is inoperative or malfunctioning, the designated person responsible for supervising the lifting operations shall establish procedures for conducting the lifts in accordance with [paras. 5-3.2.1.1\(a\)](#) through [5-3.2.1.1\(d\)](#).

(6) When a level indicator is inoperative or malfunctioning, other means shall be used to level the crane within the level requirements specified by the manufacturer.

5-3.2.1.3 Attaching the Load

(a) The hoist rope shall not be wrapped around the load.

(b) The load shall be attached to the hook by means of slings or other devices of sufficient capacity.

5-3.2.1.4 Holding the Load

(a) The operator shall not leave the controls while the load is suspended, except as permitted in [\(d\)](#) below.

(b) No person should be permitted to stand or pass under a suspended load.

(c) If the load hoist mechanism is not equipped with an automatic brake and the load must remain suspended for any considerable length of time, the operator shall hold the drum from rotating in the lowering direction by activating the device specified in [para. 5-1.3.2\(a\)\(4\)](#). The boom hoist brakes shall be set and the device specified in [para. 5-1.3.1\(c\)](#) shall be engaged.

(d) As an exception to [\(a\)](#) above, under those circumstances requiring a load to be held suspended for a period of time exceeding normal lifting operations, the operator may leave the controls provided that, prior to that time, the appointed individual and operator shall establish the requirements for restraining the boom hoist, telescoping, load, swing, and outrigger functions, and provide notices, barricades, or whatever other precautions may be necessary.

5-3.2.1.5 Moving the Load

(a) The person directing the lift shall see that

(1) the crane is level and, where necessary, blocked

(2) the load is well secured and balanced in the sling or lifting device before it is lifted more than a few inches

(3) the lift and swing path is clear of obstructions

(4) all persons are clear of the swing radius of the crane counterweight

(b) Before starting to lift, the following conditions should be noted:

(1) The hoist rope shall not be kinked.

(2) Multiple-part lines shall not be twisted around each other.

(3) The hook shall be brought over the load in such a manner as to minimize swinging.

(4) If there is a slack rope condition, it shall be determined that the rope is seated on the drum and in the sheaves as the slack is removed.

(5) The effect of ambient wind on the load and on crane stability.

(c) During lifting operations, care shall be taken that

(1) there is no sudden acceleration or deceleration of the moving load

(2) load, boom, or other parts of the machine do not contact any obstruction

(d) Side loading of booms shall be limited to freely suspended loads. Cranes shall not be used for dragging loads sideways.

(e) The operator should avoid carrying loads over people.

Figure 5-3.2.1.5-1 Examples of Typical Unequal Outrigger Extension Positions

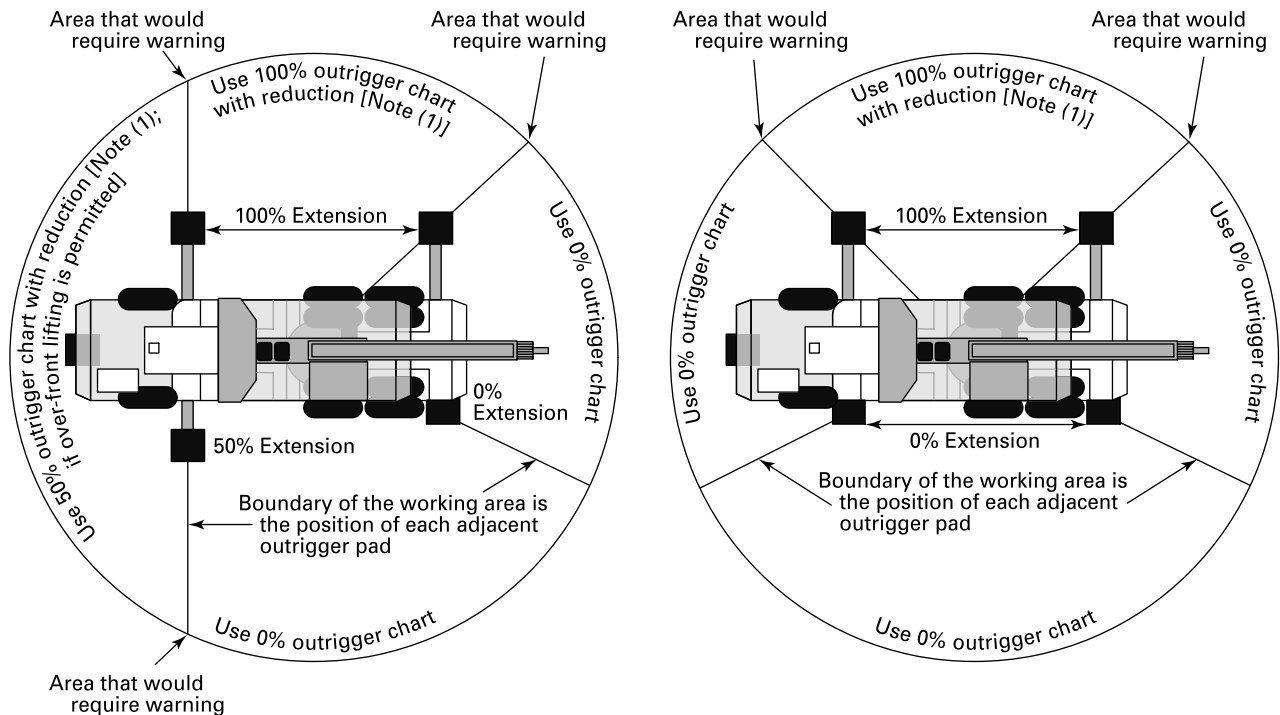

GENERAL NOTE:

These examples are not recommendations of load rating charts to be used for any specific outrigger configuration. These examples are only for clarification of [para. 5-3.2.1.5\(j\)\(3\)](#).

NOTE:

(1) If any outrigger on a side opposite the lifting area is not fully extended, the manufacturer's load rating chart being used shall be appropriately reduced and consideration shall be given to possible backward stability limitations.

(f) On wheel-mounted cranes, no loads shall be lifted over the front area, except as specified by the crane manufacturer.

(g) The operator shall test the brakes each time a load approaching the rated load is handled by lifting it a few inches and applying the brakes.

(h) Any time outriggers are used, the outriggers shall be extended or deployed per the crane manufacturer's instructions and, if specified, set to remove the machine weight from the wheels, except for locomotive cranes. [For locomotive cranes, refer to (1) below.]

(i) When outrigger floats are used, they shall be attached to the outriggers. Blocking under outrigger floats, when required, shall meet the following requirements:

(1) sufficient strength to prevent crushing, bending, or shear failure

(2) such thickness, width, and length as to completely support the float, transmit the load to the supporting surface, and prevent shifting, toppling, or excessive settlement under load

(3) use of blocking only under the outer bearing surface of the extended outrigger beam

(j) When partially extended outriggers are used, the following requirements, when applicable, shall be met:

(1) Crane operation with partially extended outriggers shall only be undertaken if approved by the crane manufacturer.

(2) Outriggers shall be set at equal positions that correspond to the load rating charts supplied by the manufacturer for those positions. Only the load rating chart(s) corresponding to the outrigger positions shall be used for operation.

(3) When situations arise where outriggers must be set at unequal positions that correspond to the load rating charts supplied by the manufacturer (see [Figure 5-3.2.1.5-1](#)), the load rating charts corresponding with the individual quadrants of operation shall be used. The manufacturer or qualified person shall be consulted to determine if any capacity reductions, special operating procedures, or limitations are required.

(-a) The crane operator shall approve the setup of the crane. If a crane operator has a supervisor involved in crane setup, the operator and the supervisor shall discuss and agree upon any required limitations.

(-b) A means shall be provided to limit crane movement or to warn the operator of proximity to prohibited operational ranges or areas.

(4) When situations arise that will not permit outriggers to be set at positions that correspond to the locations established by the manufacturer's load rating chart(s), the crane manufacturer shall be consulted to determine if any capacity reductions, special operating procedures, or limitations are required. If required information is not available from the manufacturer, a qualified person shall be consulted.

(k) Neither the load nor the boom shall be lowered below the point where less than two full wraps of rope remain on their respective drums.

(l) When lifting loads with locomotive cranes without using outriggers, the manufacturer's instructions shall be followed regarding truck wedges or screws. When using outriggers to handle loads, the manufacturer's instructions shall be followed.

(m) When two or more cranes are used to lift one load, one designated person shall be responsible for the operation. That person shall analyze the operation and instruct all personnel involved in the proper positioning, rigging of the load, and the movements to be made. Decisions such as the necessity to reduce crane ratings, load position, boom location, ground support, and speed of movement shall be in accordance with this analysis.

(n) While in transit, the following additional precautions shall be exercised:

(1) The boom should be carried in line with the direction of motion.

(2) The superstructure shall be secured against rotation (or the boom placed in a boom rack mounted on the carrier), except when negotiating turns when there is an operator in the cab or the boom is supported on a dolly.

(3) The empty hook shall be lashed or otherwise restrained so that it cannot swing freely.

(o) Before traveling a crane with a load, it shall be determined that this practice is not prohibited by the manufacturer. If not, a designated person shall be responsible for the operation. Decisions such as the necessity to reduce crane ratings, load position, boom location, ground support, travel route, and speed of movement shall be in accordance with that person's determination. Specified tire pressure shall be maintained. The boom should be carried in line with the direction of travel. Sudden starts and stops should be avoided. Tag or restraint lines should be used to control swinging of the load.

(p) A crane with or without a load shall not be traveled with the boom so high that it may bounce back over the cab.

(q) When rotating the crane, sudden starts and stops shall be avoided. Rotational speed shall be such that the load does not swing out beyond the radius at which it can be controlled. A tag or restraint line shall be used when rotation of the load is hazardous.

(r) When a crane is to be operated with the boom at a fixed angle, the boom-hoist pawl or other positive holding device shall be engaged.

(s) *Use of Winch Heads*

(1) Fiber and wire rope shall not be handled on a winch head without the knowledge of the operator.

(2) While a winch head is being used, the operator shall be within convenient reach of the power unit control lever.

(t) Personnel shall not be permitted to ride the bare hook or a load of material suspended from the hook.

5-3.2.1.6 Wind Speed Device. Wind speed shall be monitored at all sites where it can adversely affect crane operations. This should be accomplished with a device mounted at the highest unshielded point on the crane or located at the site.

5-3.2.2 Personnel Lifting

This Volume recognizes that mobile and locomotive cranes are designed and intended for handling materials and not personnel. Personnel are only permitted to ride in a personnel platform supported by the crane load line attachment or boom-mounted platform when used in accordance with the requirements of ASME B30.23 and the crane manufacturer's instructions. The crane shall not be used for other purposes while handling personnel. (Refer to ASME B30.23.)

5-3.2.3 Multiple Load Line Operation

Multiple load line operation shall only be permitted when the equipment and procedures required by this Volume and those required by the crane manufacturer or qualified person are applied.

(a) Simultaneously lifting or suspending individual loads on separate lines is prohibited.

(b) Personnel lifting is prohibited.

(c) Before operation with multiple load lines begins, the following actions shall be accomplished:

(1) A qualified person shall approve the planned operation.

(2) The lift director shall ensure that the crane operator has selected the correct load rating charts (e.g., boom or jib load rating chart) for the configuration being used, i.e., position of the load being lifted, lifting points, etc.

(3) The crane operator and the lift director shall verify that the load on any individual load line and the total weight of the load including hook blocks, hook balls, slings and rigging, etc., do not exceed the capabilities of the crane.

(4) The crane operator and the lift director shall review the operational characteristics and limitations of the crane established by the crane manufacturer or qualified person that relate to simultaneous multiple

drum operation, i.e., same or opposite direction of rotation of drums, limited rope layers on tandem drums, etc.

(d) Each load line shall be equipped with an anti-two-block device.

(e) Unless each lift point is capable of individually supporting the entire load weight, each load line shall be equipped with a load indicator readable during the lift by a designated person.

(f) Prior to and during lifting operations, load lines and rigging shall be monitored for interference. If interference occurs, operations shall be stopped and a qualified person shall determine whether the interference constitutes a hazard. Any hazard identified shall be corrected before lifting operations continue.

(g) Side loading of booms, jibs, and sheaves shall not exceed the limitations established by the crane manufacturer.

5-3.2.4 Critical Lifts

Certain hoisting or lifting operations are recognized to have increased levels of risk to personnel or property. The criteria to categorize a lift as “critical” on this basis are established by site supervision, project management, a qualified person, or company policies. Lift planning and oversight shall be tailored to each hoisting operation and shall be sufficient to manage varying conditions and their associated hazards. The information presented in [Nonmandatory Appendix A](#) suggests one method of documenting the planning and oversight necessary to reduce that risk.

SECTION 5-3.3: SIGNALS

5-3.3.1 General

(a) Communication between the crane operator and the signalperson shall be maintained continuously during all crane movements. If at any time communication is disrupted, the operator shall stop all crane movements until communication is restored and a proper signal is given and understood.

(b) If the operator has any concerns regarding the requested movement of the crane or needs to communicate with the signalperson, the operator shall stop all crane movement. Crane movement shall not resume until the operator and the signalperson agree that the issue at hand has been resolved.

(c) If it is desired to give instructions to the operator, other than those provided by the established signal system, the crane movements shall be stopped.

5-3.3.2 Standard Signals

Standard signals to the operator shall be in accordance with the standards prescribed in [para. 5-3.3.4](#) or [para. 5-3.3.5](#). Signals shall be discernible or audible at all times. No

response shall be made unless signals are clearly understood.

5-3.3.3 Signalperson Qualifications

Prior to signaling crane operations, all signalpersons shall be tested by a designated person and demonstrate their qualifications in the following areas:

(a) basic understanding of crane operation and limitations

(b) standard hand signals described in [para. 5-3.3.4](#) whenever hand signals are used

(c) standard voice signals described in [para. 5-3.3.5](#) whenever voice signals are used

5-3.3.4 Standard Hand Signals

Hand signals shall be as shown in [Figure 5-3.3.4-1](#) and shall be posted conspicuously at the jobsite.

5-3.3.5 Standard Voice Signals

Prior to beginning lifting operations using voice signals, the signals shall be discussed and agreed upon by the person directing lifting operations, the crane operator, and the appointed signalperson.

(a) Telephones, radios, or equivalent, if used, shall be tested before lifting operations begin. If the system is battery powered, extra batteries should be available at the jobsite.

(b) Prior to commencing a lift, the operator and signalperson shall contact and identify each other.

(c) All directions given to the crane operator by the signalperson shall be given from the operator’s direction perspective (e.g., swing right).

(d) Each series of voice signals shall contain three elements stated in the following order:

- (1) function and direction
- (2) distance and/or speed
- (3) function stop

NOTE: These are some examples of signals.

(a) swing right 50 ft, 25 ft, 15 ft, 10 ft, 5 ft, 2 ft, swing stop

(b) load down 100 ft, 50 ft, 40 ft, 30 ft, ..., 2 ft, load stop

(c) load up slow, slow, slow, load stop



(e) For lifting operations using voice signals, the person directing lifting operations shall consider the complexity of the lift, the capabilities of the particular crane, the experience and skill of the operator and signalperson, and the ability to communicate the necessary signals before permitting multiple simultaneous crane function signals.

5-3.3.6 Special Signals

For operations or crane attachments not covered by [para. 5-3.3.4](#), [para. 5-3.3.5](#), or [para. 5-3.3.7](#), additions to or modifications of the standard signal procedures may be required. In all such cases, the required special



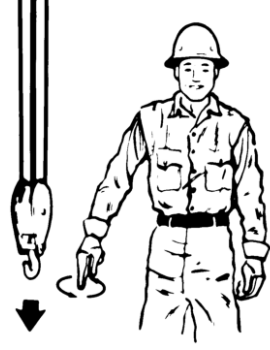
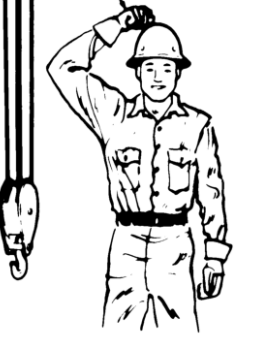

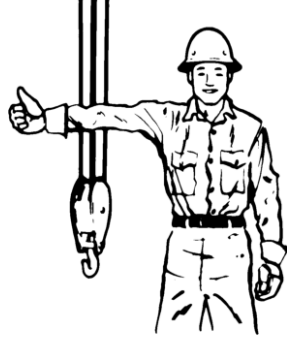
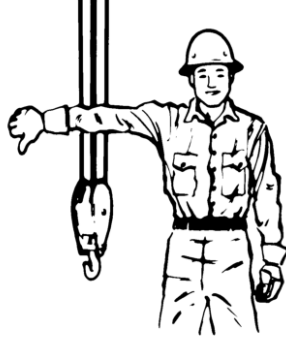
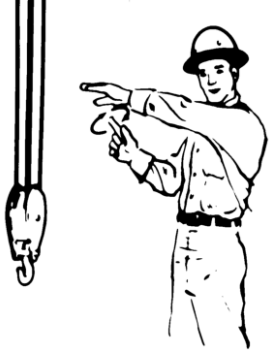
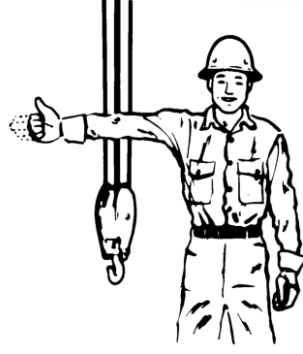
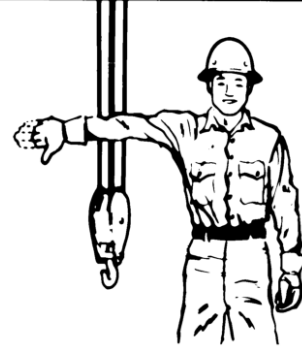
(18)

Figure 5-3.3.4-1 Standard Hand Signals for Controlling Crane Operations

 <p>HOIST. With forearm vertical, forefinger pointing up, move hand in small horizontal circle.</p>	 <p>LOWER. With arm extended downward, forefinger pointing down, move hand in small horizontal circle.</p>	 <p>USE MAIN HOIST. Tap fist on head; then use regular signals.</p>
 <p>USE WHIP LINE (Auxiliary Hoist). Tap elbow with one hand; then use regular signals.</p>	 <p>RAISE BOOM. Arm extended, fingers closed, thumb pointing upward.</p>	 <p>LOWER BOOM. Arm extended, fingers closed, thumb pointing downward.</p>
 <p>MOVE SLOWLY. Use one hand to give any motion signal and place other hand motionless in front of hand giving the motion signal. (Hoist slowly shown as example.)</p>	 <p>RAISE THE BOOM AND LOWER THE LOAD. With arm extended, thumb pointing up, flex fingers in and out as long as load movement is desired.</p>	 <p>LOWER THE BOOM AND RAISE THE LOAD. With arm extended, thumb pointing down, flex fingers in and out as long as load movement is desired.</p>

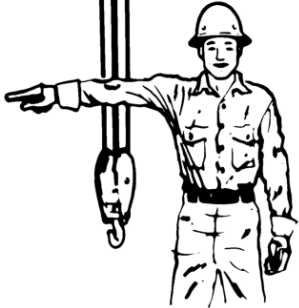
(18)

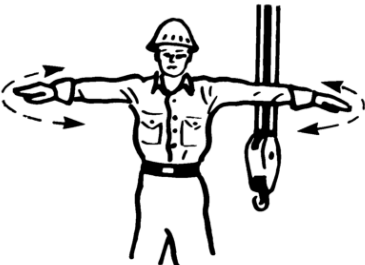
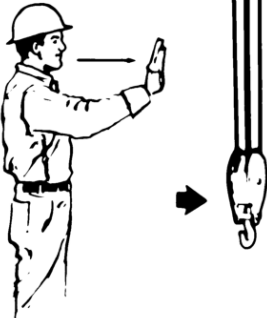
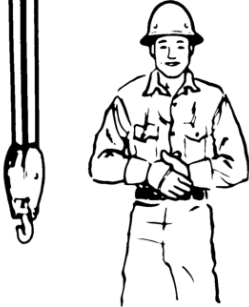
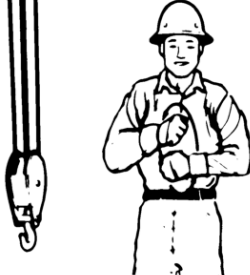
Figure 5-3.3.4-1 Standard Hand Signals for Controlling Crane Operations (Cont'd)

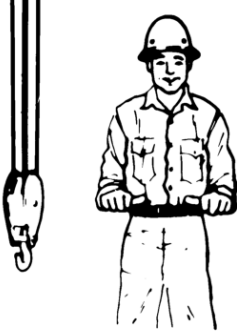
 <p>SWING. Arm extended, point with finger in direction of swing of boom.</p>	 <p>STOP. Arm extended, palm down, move arm back and forth horizontally.</p>	 <p>EMERGENCY STOP. Both arms extended, palms down, move arms back and forth horizontally.</p>
 <p>TRAVEL. Arm extended forward, hand open and slightly raised, make pushing motion in direction of travel.</p>	 <p>DOG EVERYTHING. Clasp hands in front of body.</p>	 <p>TRAVEL (Both Tracks). Use both fists in front of body, making a circular motion about each other, indicating direction of travel, forward or backward. (For land cranes only.)</p>
 <p>TRAVEL (One Track). Lock the track on side indicated by raised fist. Travel opposite track in direction indicated by circular motion of other fist, rotated vertically in front of body. (For land cranes only.)</p>	 <p>EXTEND BOOM (Telescoping Booms). Both fists in front of body with thumbs pointing outward.</p>	 <p>RETRACT BOOM (Telescoping Booms). Both fists in front of body with thumbs pointing toward each other.</p>

(18)

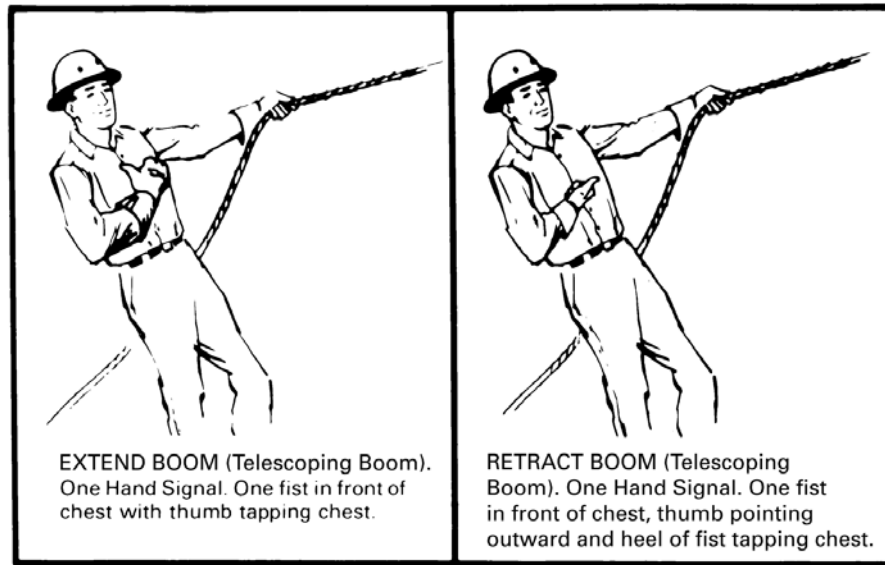
Figure 5-3.3.4-1 Standard Hand Signals for Controlling Crane Operations (Cont'd)

signals shall be agreed upon in advance by the person directing lifting operations, the crane operator, and the signalperson. These special signals should not be in conflict with the standard signals.

5-3.3.7 Audible Travel Signals

When moving the vehicle, the following signals shall be used:

- (a) STOP: one short audible signal
- (b) GO AHEAD: two short audible signals
- (c) BACK UP: three short audible signals

5-3.3.8 Audible Emergency Signal

Emergency signals can be given by anyone. The signal used shall be agreed upon for each jobsite location and it shall meet the requirements of [para. 5-3.3.6](#) (e.g., multiple short audible signals or a continuous audible signal).

SECTION 5-3.4: MISCELLANEOUS

5-3.4.1 Rail Clamps

Rail clamps, if used, should have some slack between the point of attachment to the rail and the end fastened to the crane. Rail clamps shall not be used as a means of restraining tipping of a locomotive crane.

5-3.4.2 Ballast or Counterweight

Cranes shall not be operated without the ballast or counterweight being in place as specified by the crane manufacturer. Under specific conditions, such as during crane assembly or unusual boom configurations, the crane manufacturer's recommendations for the

amount of ballast or counterweight shall be adhered to. The maximum ballast or counterweight approved by the manufacturer for use on a given machine shall not be exceeded. Unauthorized addition of ballast or counterweight constitutes a hazard in two ways.

(a) The structural competence of the various parts of the machine may be exceeded, causing failure.

(b) The manufacturer's margin of backward stability may be exceeded and the crane may turn over backwards or damage various parts of the machine.

5-3.4.3 Rerailing Locomotive Cranes

If a locomotive crane has been derailed, a wrecking frog or car replacer (or its equivalent) should be used and the crane should be hauled back onto the track by external power.

5-3.4.4 Swinging Locomotive Cranes

A locomotive crane shall not be swung into a position where railway cars on an adjacent track might strike it, until it has been ascertained that cars are not being moved on the adjacent track and that proper flag protection has been established.

5-3.4.5 Crane Operation in the Vicinity of Electric Power Lines (18)

5-3.4.5.1 General. This Volume recognizes that crane operation, including load handling, assembling, disassembling, inspecting, and maintaining mobile cranes where they can become energized by electric power lines, can be an extremely hazardous practice. When required to work in the vicinity of electric power lines, the

requirements below shall be followed to address the hazard. However, working in the vicinity of electric power lines should be avoided whenever possible. See [Figure 5-3.4.5.1-1](#) to determine the subsection to reference in a given situation.

[Figure 5-3.4.5.1-2](#) illustrates the specified clearance around an energized electric power line and how crane position and configuration can affect the ability to remain outside the specified clearance. [Figure 5-3.4.5.1-3](#) illustrates the specified clearance around an energized electric power line that shall be maintained when the crane is in travel or transit.

(a) To prevent the crane, load line, rigging, or load from becoming a conductive path when operating in the vicinity of energized electric power lines, the specified clearance shall be maintained at all times. The following two ways can be used to determine the specified clearance:

(1) Preferred Method: have a qualified representative of the utility owner/operator of the electric power lines determine the voltage and elevation of the electric power lines. Use [Table 5-3.4.5.1-1](#) to determine the specified clearance.

(2) Alternate Method: estimate the voltage of the electric power lines by comparing the electric power line support structures to those depicted in [Figure 5-3.4.5.1-4](#). If multiple electric power line support structures are in the vicinity of the worksite, use the highest typical voltage shown in [Figure 5-3.4.5.1-4](#). Maintain a specified clearance of 20 ft for electric power lines with typical voltages below or equal to 350 kV and a specified clearance of 50 ft for electric power lines with typical voltages above 350 kV.

(b) Operation of mobile cranes where they can become energized by electric power lines shall not be performed unless the requirements of this section are followed.

(c) Additional precautions and measures may need to be taken beyond those identified in this Volume for crane operation, transit, or travel in the vicinity of electric power lines when snow, ice, rain, fog, wind, darkness, or other conditions or environments affect visibility or induce unwanted movement or position of the crane, load, or electric power lines. These precautions or measures may include, but are not limited to, additional spotters, warning systems, increased distance from specified clearance, and procedures.

(d) Crane operators, signalpersons, riggers, and other involved personnel shall receive training on, as well as an evaluation of their understanding of, the electrical hazards associated with crane operation in the vicinity of electric power lines, the requirements of this section, and the procedures and emergency responses that are to be implemented should the equipment (crane, rigging, and lifting accessories), load line, or load become energized.

(e) Any overhead wire shall be considered to be an energized electric power line unless and until the utility owner/operator of the electric power lines indi-

cates that it is deenergized, and for transmission and distribution lines, that the electric power lines are visibly grounded at the jobsite. Crane operators and other personnel directly involved with the lifting operations shall not rely on the coverings of wires for protection.

(f) Operation of boom and load over energized electric power lines is extremely dangerous, due to possible misperception of distance and multiple contact points as viewed from the position of the operator and/or position of the signalperson. The operator should avoid operating the crane, with or without a load, in this area.

(g) If cage-type boom guards, insulating links, or proximity warning devices are used on cranes, such devices shall not be a substitute for the requirements of this section, even if such devices are required by law or regulation. Electrical hazards are complex, invisible, and lethal. To lessen the potential of false security, instructions related to the devices and hazards shall be reviewed with the crane operator, crew, and load-handling personnel. Instructions shall include information about the electrical hazard(s) involved, operating conditions for the devices, limitations of such devices, and testing requirements prescribed by the device manufacturer. The specified clearances to electric power lines, established in [Table 5-3.4.5.1-1](#), shall be maintained, regardless of any devices used on the crane.

(h) Before beginning operations, the site supervisor shall ensure that

(1) The area of crane placement at the worksite has been established.

(2) The crane to be used and its configuration have been identified.

(3) The area 360 deg around the crane has been defined up to the maximum horizontal reach.

(4) The dimensions of the load(s), rigging, and rigging accessories that will be used have been identified.

(5) A preliminary determination is made if any part of the equipment, load line, or load, if operated at the crane's maximum horizontal reach, has the capability to get closer than the specified clearance.

(6) The applicable paragraph listed in [para. \(j\)](#) below and the requirements to be followed to address the given condition are identified.

(7) The lift director has the information contained in [\(1\)](#) through [\(6\)](#) above.

(i) The lift director shall reevaluate the information contained in [\(h\)\(1\)](#) through [\(h\)\(6\)](#) above whenever changes that affect the crane position, crane configuration, or lift plan are required during operation.

(j) The following paragraphs provide additional requirements:

[5-3.4.5.2](#) Operation in the Vicinity of Deenergized and Grounded Electric Power Transmission and Distribution Lines

[5-3.4.5.3](#) Operation in the Vicinity of Deenergized Electric Power Lines Other Than Transmission and Distribution Lines

Figure 5-3.4.5.1-1 Flowchart to Assist in Determination of the Applicable Subsection for Crane Operation Near Electric Power Lines

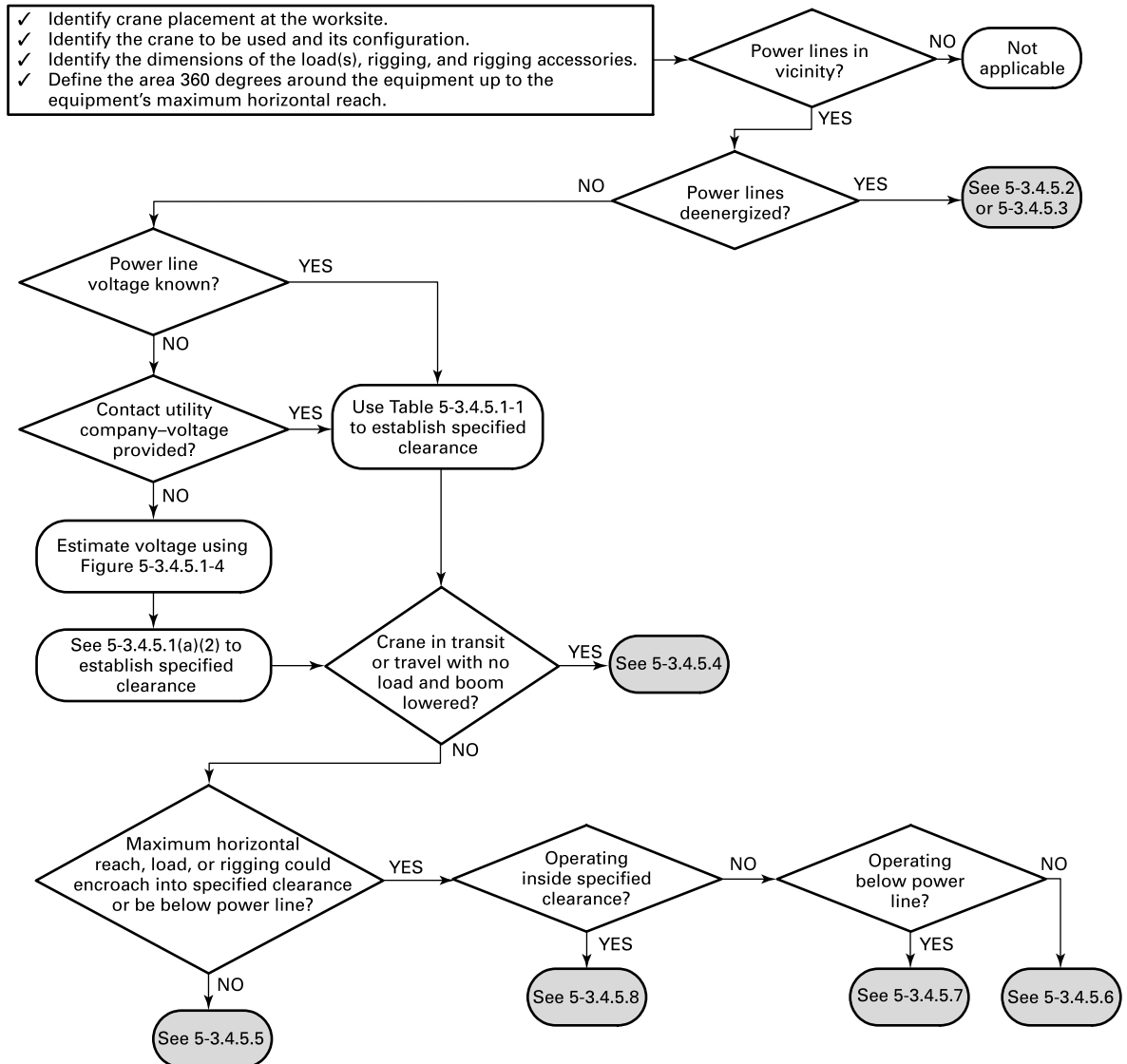

GENERAL NOTE: Any changes that affect the crane position, crane configuration, or any part of the lift plan shall require reevaluation.

Figure 5-3.4.5.1-2 Specified Clearance Around an Energized Electric Power Line

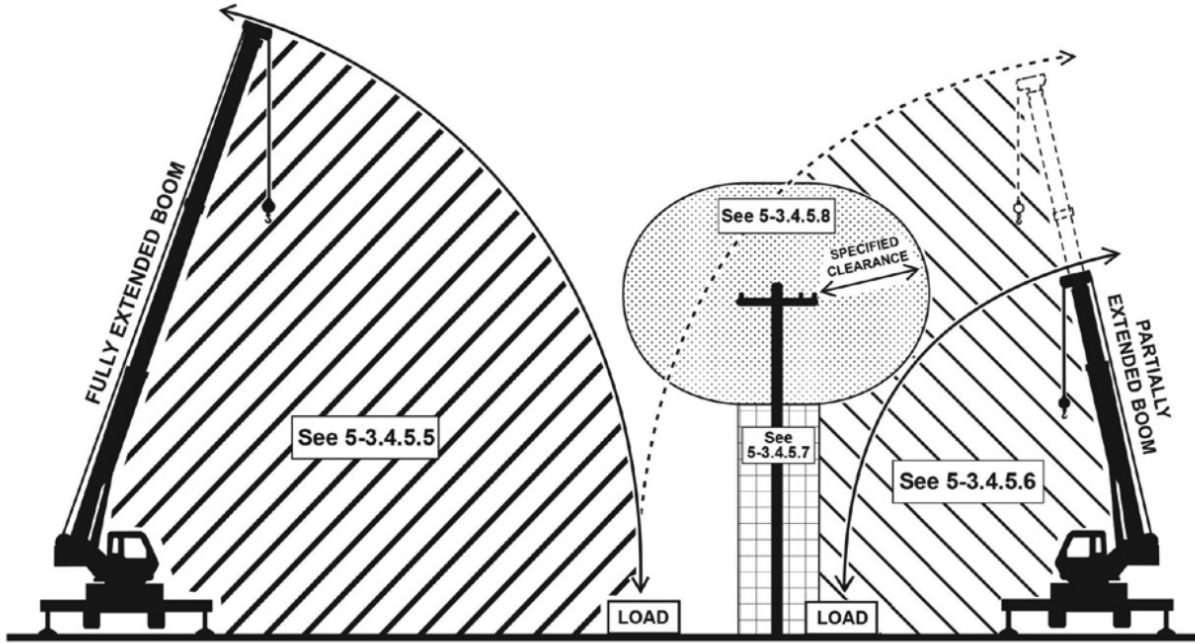

(a)

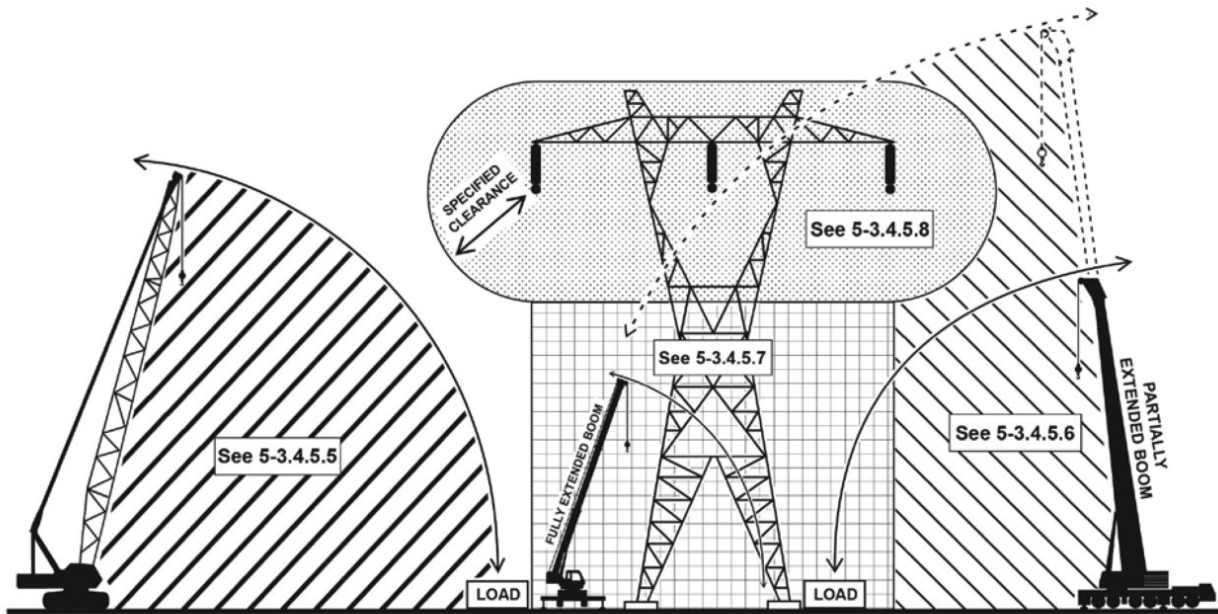

(b)

Figure 5-3.4.5.1-3 Specified Clearance Around an Energized Electric Power Line That Shall Be Maintained When the Crane Is in Travel or Transit

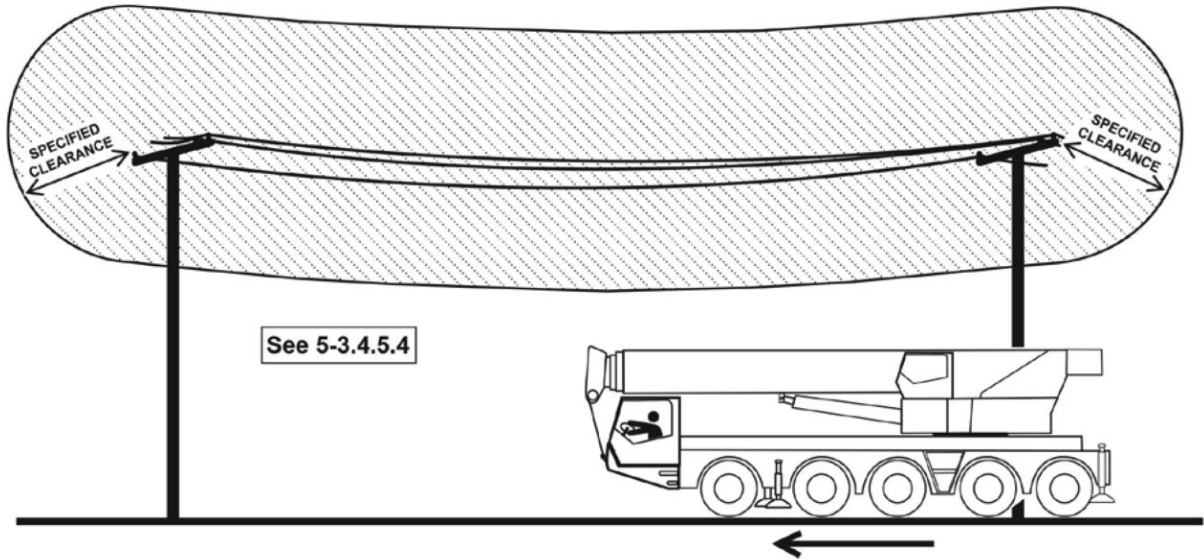

- 5-3.4.5.4 Transit or Travel in the Vicinity of Energized Electric Power Lines With No Load and Boom Lowered
- 5-3.4.5.5 Operation in the Vicinity of Energized Electric Power Lines and the Crane Configuration May Not Be Capable of Reaching Within the Specified Clearance
- 5-3.4.5.6 Operation in the Vicinity of Energized Electric Power Lines and the Crane Configuration May Be Capable of Reaching Within the Specified Clearance
- 5-3.4.5.7 Operation Below Energized Electric Power Lines
- 5-3.4.5.8 Operation Within the Specified Clearance With the Electric Power Lines Energized

5-3.4.5.2 Operation in the Vicinity of Deenergized and Grounded Electric Power Transmission and Distribution Lines.

This is the preferred condition for crane operation when the crane is required to work in the vicinity of power transmission and distribution lines since the hazard of injury or death due to electrocution has been removed.

The following steps shall be taken to ensure the electric power lines are deenergized:

- (a) The utility owner/operator of the electric power lines shall deenergize the electric power lines.
- (b) The electric power lines shall be visibly grounded to avoid electrical feedback and appropriately marked at the jobsite location.

(c) A qualified representative of the utility owner/operator of the electric power lines shall come to the site to verify that the steps of (a) and (b) above have been completed and that the electric power lines are deenergized and grounded.

Table 5-3.4.5.1-1 Specified Clearance in the Vicinity of Energized Electric Power Lines

Normal Voltage, kV (Phase to Phase)	Specified Clearance, ft (m)
During Operation	
Up to 50	10 (3)
Over 50 to 200	15 (4.6)
Over 200 to 350	20 (6.1)
Over 350 to 500	25 (7.6)
Over 500 to 750	35 (10.7)
Over 750 to 1,000	45 (13.7)
Over 1,000	Determine specified clearance after consultation with utility owner/operator
During Transit or Travel With No Load and Boom or Mast Lowered	
Up to 0.75	4 (1.2)
Over 0.75 to 50	6 (1.8)
Over 50 to 345	10 (3.1)
Over 345 to 750	16 (4.9)

5-3.4.5.3 Operation in the Vicinity of Deenergized Electric Power Lines Other Than Transmission and Distribution Lines.

This is the preferred condition for crane operation when the crane is required to work in the vicinity of electric power lines that are not in transmission or distribution service and that are insulated for the voltage at which they operate since the hazard of injury or death due to electrocution has been removed. The following steps shall be taken to ensure the electric power lines are deenergized:

- (a) The utility owner/operator of the electric power lines shall deenergize the electric power lines.

Figure 5-3.4.5.1-4 Electric Power Line Support Structures

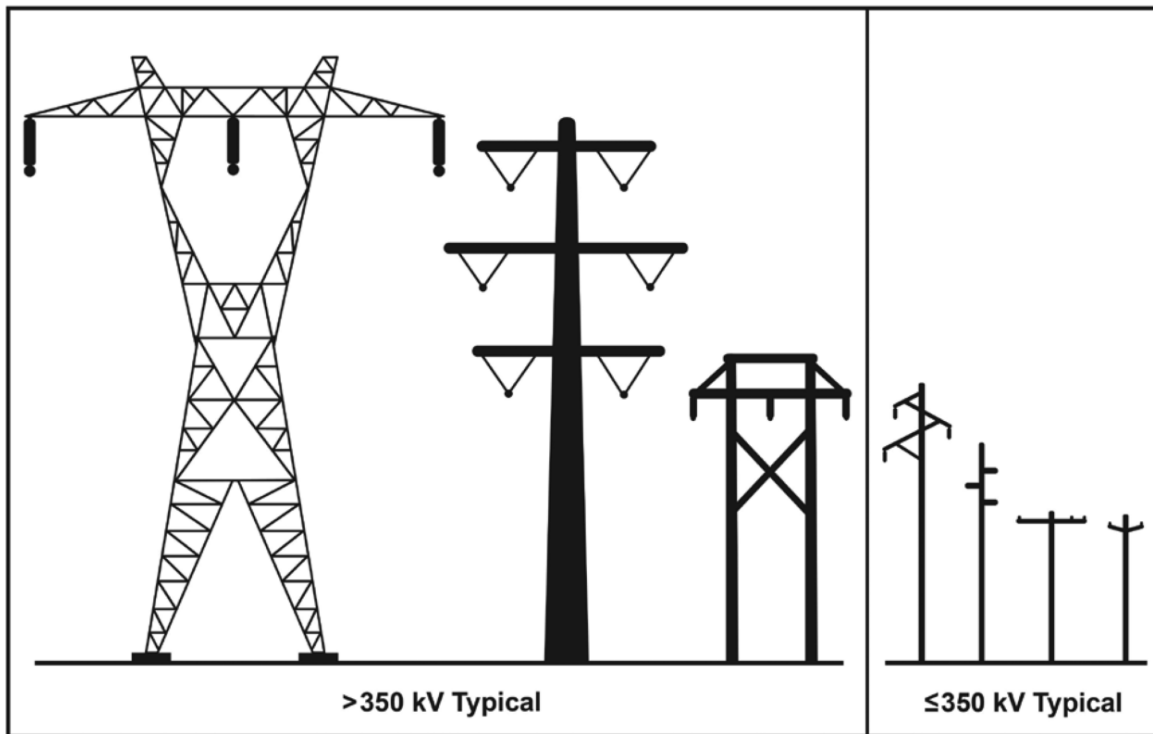

(b) The necessity for grounding the electric power lines shall be determined by the utility owner/operator of the electric power lines.

(c) A qualified representative of the utility owner/operator of the electric power lines shall come to the site to verify that the steps of (a) and (b) above have been completed and that the electric power lines are deenergized.

5-3.4.5.4 Transit or Travel in the Vicinity of Energized Electric Power Lines With No Load and Boom Lowered

(a) While the crane is in transit or traveling with no load and the boom and boom support system are sufficiently lowered, the specified clearance in Table 5-3.4.5.1-1 shall be maintained. When planning transit or travel of the crane, the effect of speed and terrain on boom and crane movement shall be considered.

(b) While traveling, a dedicated spotter shall be used if any part of the equipment will be within 20 ft (6.1 m) of an electric power line at any time.

5-3.4.5.5 Operation in the Vicinity of Energized Electric Power Lines and the Crane Configuration May Not Be Capable of Reaching Within the Specified Clearance. No part of the equipment, load line, or load shall be allowed in the vicinity of an electric power line unless the electric power lines are deenergized in accordance with para. 5-3.4.5.2 or para. 5-3.4.5.3 or where the electric power lines remain energized for

crane operations in the vicinity of electric power lines, the following is required:

(a) The horizontal and vertical distance of movement of electric power lines due to the wind, sag, or other conditions shall be added to the initial specified clearance.

(b) Evaluate if the equipment, load line, or load is capable of reaching within the resultant specified clearance.

(1) If the equipment, load line, or load is capable of entering within the resultant specified clearance and the crane is not operating below energized electric power lines, the requirements applicable under either para. 5-3.4.5.6 or para. 5-3.4.5.8 shall be followed.

(2) If the equipment, load line, or load is not capable of reaching within the resultant specified clearance and the crane is not operating below energized electric power lines, the lift director shall conduct an on-site planning meeting with the operator and the other workers who will be in the area of the equipment or load to review the location of the power line(s).

5-3.4.5.6 Operation in the Vicinity of Energized Electric Power Lines and the Crane Configuration May Be Capable of Reaching Within the Specified Clearance. No part of the equipment, load line, or load shall be allowed in the vicinity of an electric power line unless the lines are deenergized in accordance with para. 5-3.4.5.2 or para. 5-3.4.5.3 or where the electric

power lines remain energized for crane operations in the vicinity of electric power lines, the following is required:

(a) The horizontal and vertical distance of movement of electric power lines due to the wind, sag, or other conditions shall be added to the initial specified clearance.

(b) Evaluate if the equipment, load line, or load is capable of reaching within the resultant specified clearance.

(1) If the equipment, load line, or load is not capable of reaching within the resultant specified clearance and the crane is not operating below energized electric power lines, the requirements applicable under [para. 5-3.4.5.5](#) shall be followed.

(2) If the equipment, load line, or load is capable of reaching within the resultant specified clearance but the work is planned so that the equipment, load line, or load shall not enter into the specified clearance and the crane is not operating below energized electric power lines, the following steps shall be taken to minimize the hazard of electrocution or serious injury as a result of contact between the energized electric power lines and the equipment, load line, or load:

(-a) The equipment, load line, or load shall not enter into the resultant specified clearance.

(-b) The lift director shall conduct an on-site planning meeting with the operator and the other workers who will be in the area of the equipment or load to review the location of the electric power line(s) and the steps that shall be implemented to prevent encroachment/electrification.

(-c) Tag lines, when required, shall be of a nonconductive type. Nonconductive material can become conductive when exposed to moisture or contamination.

(-d) Erect and maintain an elevated warning line, barricade, or line of signs, in view of the operator, equipped with flags or similar high-visibility markings to mark the working radius at or farther than the specified clearance distance from the electric power lines.

(-e) Implement at least one of the following measures. If at any time the operator is unable to see the elevated warning line, barricade, or line of signs, a dedicated spotter shall be used in addition to complying with [\(-2\)](#) or [\(-3\)](#) below.

(-1) A dedicated spotter shall

(+a) be equipped with a visual aid to assist in identifying the specified clearance distance.

(+b) be positioned to accurately gauge the clearance distance.

(+c) when necessary, use equipment that enables direct communication with the operator.

(+d) give timely information to the operator so that the specified clearance can be maintained.

(-2) A device that automatically warns the operator when to stop movement shall be set to give the operator sufficient warning to prevent encroachment.

(-3) A device that automatically limits the range of movement shall be set to prevent encroachment.

5-3.4.5.7 Operation Below Energized Electric Power Lines.

No part of the crane, load line, or load (including rigging and lifting accessories) shall be allowed directly below an electric power line unless the electric power lines are deenergized in accordance with [para. 5-3.4.5.2](#) or [para. 5-3.4.5.3](#) or where the electric power lines remain energized during crane operations below electric power lines, the following is required:

(a) The horizontal and vertical distance of movement of electric power lines due to the wind, sag, or other conditions shall be added to the initial specified clearance as established in [para. 5-3.4.5.1](#). A qualified representative of the utility owner/operator of the electric power lines shall be consulted for specific movement distances.

(b) Identify if the crane is capable of reaching within the resultant specified clearance.

(1) If the load or uppermost part of the crane is capable of entering within the resultant specified clearance and the crane is operating below energized electric power lines, the requirements of [para. 5-3.4.5.8](#) shall be followed even if the work is not within the specified clearance.

(2) If the load or uppermost part of the crane is not capable of reaching within the resultant specified clearance, the lift director shall conduct an on-site planning meeting with the operator and the other workers who will be in the area of the equipment or load to review the location of the electric power lines.

5-3.4.5.8 Operation Within the Specified Clearance With the Electric Power Lines Energized.

The following steps shall be taken to minimize the hazard of electrocution or serious injury as a result of contact between the energized electric power lines and the equipment, load line, or load.

Before such operations take place, the lift director, together with a qualified representative of the utility owner/operator of the electric power lines or an engineer qualified in electrical power transmission, shall, after visiting the site, determine if this is the most feasible way to complete the operation and set minimum approach distances and procedures for such operations. The procedures developed to comply with this section shall be documented and readily available on site. These operations shall be under their supervision. The following shall be required:

(a) The lift director shall conduct an on-site planning meeting with the operator and the other workers who will be in the area of the equipment or load to review the location of the electric power line(s) and the steps that shall be implemented to prevent encroachment/electrification.

(b) Electrical system protective devices that automatically reenergize a circuit after an electrical power line contact occurrence shall be blocked or disengaged to inhibit this function.

(c) A dedicated spotter shall

(1) be equipped with a visual aid to assist in identifying the minimum approach distances.

(2) be positioned to accurately gauge the minimum approach distances.

(3) where necessary, use equipment that enables direct communication with the operator.

(4) give timely information to the operator so that the minimum approach distances can be maintained.

(d) There shall be an elevated warning line, or barricade (not attached to the crane), in view of the operator (either directly or through video equipment), equipped with flags or similar high-visibility markings, to prevent electrical contact.

(e) If the rigging will be within the specified clearance, it shall be nonconductive-type rigging. Nonconductive material can become conductive when exposed to moisture or contamination.

(f) If the crane is equipped with a device that automatically limits range of movement, the device shall be used and set to prevent any part of the equipment, load line, or load (including rigging and lifting accessories) from breaching the minimum approach distances established.

(g) Tag lines, when required, shall be of a nonconductive type. Nonconductive material can become conductive when exposed to moisture or contamination.

(h) Nonconductive barricades shall be used to form a perimeter to restrict access to the crane work area.

(i) Nonessential personnel shall be removed from and prohibited from entering the crane work area.

(j) No one shall be permitted to touch the equipment, load line, or load unless the lift director indicates that it is safe to do so.

(k) The equipment shall be grounded.

(l) Insulated barriers that are not a part of nor an attachment to the crane and will not allow contact between the energized electric power lines and the equipment, load line, or load shall be installed by the utility owner/operator of the electric power lines, except where such devices are unavailable for the line voltages involved.

5-3.4.6 Induced Electrical Charges

When a potentially hazardous condition exists due to an electrical charge that can be or is being induced into the equipment or materials being handled, a qualified person shall be contacted and his/her recommendation for corrective actions shall be followed.

Common sources of induced electrical charges include energized power lines, as well as radio frequency (RF), radar, microwave, and other electromagnetic energy transmitters.

5-3.4.7 Footing

Firm footing under both crawler tracks, all tires, or individual outrigger pads should be level within 1%. Where such a footing is not otherwise supplied, it should be provided by timbers, cribbing, or other structural members to distribute the load so as not to exceed the allowable bearing capacity of the underlying material.

5-3.4.8 Cabs

(a) Necessary clothing and personal belongings shall be stored in such a manner as to not interfere with access or operation.

(b) Tools, oil cans, waste, and other necessary articles shall be stored in the toolbox, and shall not be permitted to lie loose in or about the cab.

5-3.4.9 Refueling

(a) When refueling with gasoline using a portable container, it shall be a safety-type can equipped with an automatic closing cap and a flame arrester.

(b) Machines shall not be refueled while the engine is running.

(c) Smoking or open flames shall be prohibited in the refueling area.

5-3.4.10 Fire Extinguishers

(a) A portable fire extinguisher, with a basic minimum extinguisher rating of 10 BC, shall be installed in the cab or at the machinery housing.

(b) Operating and maintenance personnel shall be familiar with the use and care of the fire extinguishers provided.

NONMANDATORY APPENDIX A CRITICAL LIFTS

(18) A-1 CRITICAL LIFT IDENTIFICATION

Classification of a lift as being “critical” is often determined by company policy but may also be determined independently by site supervision, project management, or a qualified person. It is not the purpose of the B30.5 Volume to designate, authorize, or sanction any lift as being critical. Critical lifts can occur anytime during lifting, preparation for a lift, or dismantling from a lifting operation.

Examples of commonly accepted critical lift criteria are as follows:

(a) The total load being lifted is in excess of a predetermined threshold. This threshold may vary with company policy and with consideration given to such criteria as crane capacity, available rigging, and employee experience.

(b) The lifted load exceeds a predetermined percentage of the crane’s capacity, as shown on the crane manufacturer’s applicable load rating charts for the configuration being used. Responsible management may adjust this percentage depending on the jobsite conditions.

(c) The lifting of personnel in a personnel basket or platform. Such hoisting of personnel shall follow the requirements and procedures of the B30.23 Volume and special provisions as mandated by OSHA.

(d) The lifting operation involves more than one crane lifting a common load with shared loading of both cranes. Multicrane lifts utilizing one crane, as a tailing crane, may not be considered a critical lift unless another of these listed criteria applies.

(e) The item being lifted is unique and, if damaged, would be irreplaceable or not repairable and is vital to a system, facility, or project operation.

(f) The item is being removed from a structure, such as in demolition work, where the actual weight and the structural integrity are in doubt.

(g) The lifting operation is within a boom length of power lines (see [para. 5-3.4.5](#), Crane Operation in the Vicinity of Electric Power Lines) or over active work areas, occupied buildings, public roadways, transportation systems, etc.

(h) Other crane activities such as, but not limited to, the following, which may be considered as critical lifts as determined by either site management or project supervision:

(1) lifting with limited clearance or in confined work areas

(2) lifting at heights that make control of the load difficult

(3) lifts utilizing a specially engineered load rigging system

A-2 CRITICAL LIFT PLANS

A critical lift plan, with documentation as determined by site supervision or project management, shall be prepared on all critical lifts prior to the commencement of those lifts. The lift plan shall include items necessary to address the special conditions of each lift. These items should include, but not be limited to, the following:

(a) the total weight to be lifted, which includes, but is not limited to, the weights of

(1) load

(2) block and ball

(3) below-the-hook lifting devices, lifting bars, or beams

(4) jib, erected or stowed, as applicable

(5) rigging, including slings and hardware

(6) rope, load line as applicable

(b) the crane placement location with consideration given to

(1) foundation, ground support

(2) boom swing area, as applicable

(3) track or outrigger loading

(4) electrical hazards

(5) obstructions and clearances

(6) load path

(c) identification of the crane(s) to be used describing the required configuration(s) noting

(1) capacity

(2) lifting arrangement

(3) load radius requirements

(4) percentage of crane capacity needed

(d) sling and rigging selection, which should include, but not be limited to, the following:

(1) type of arrangement

(2) identified sling angles

(3) number and size of slings

(4) sling rated capacities and lengths

(5) hardware selection and sizing

(e) diagram(s) of lifting area dimensions including

(1) site layout information and rigging arrangements

- (2) pickup and placement locations
- (3) obstructions and clearances
- (4) jobsite access and egress for the load
- (5) load orientation
- (f) diagram of rigging configuration including
 - (1) load center of gravity
 - (2) arrangement of slings and below-the-hook lifting devices
 - (3) hardware arrangements
 - (4) capacities of slings and hardware
 - (5) pick points on the load
 - (6) calculated sling angles
 - (7) types of sling hitches

A-3 CRITICAL LIFT APPROVALS

All critical lift plans shall be reviewed for approval by responsible jobsite personnel including site management, rigging supervision, the crane operator performing the lift, qualified personnel designing the lift, and safety personnel

as applicable. These approvals shall be signed and dated. Any disapproval(s) by the responsible personnel shall cause the total plan to be reexamined and, if necessary, revised to gain final approval (or to resolve any disapproval). All revisions shall also be signed and dated.

A-4 CRITICAL LIFT PRE-LIFT MEETING

Before performing a critical lift and following any revision(s) to the original plan, participating personnel shall meet to accomplish the following:

- (a) Review and discuss the details of the critical lift plan.
- (b) Discuss any hazards, delays, project coordination, unique conditions, emergency contingencies, safety concerns, etc.
- (c) Resolve any questions or concerns before commencing lifting operations.
- (d) Assign personnel and responsibilities.
- (e) Establish communication methods.

ASME Services

ASME is committed to developing and delivering technical information. At ASME's Customer Care, we make every effort to answer your questions and expedite your orders. Our representatives are ready to assist you in the following areas:

ASME Press	Member Services & Benefits	Public Information
<i>Codes & Standards</i>	Other ASME Programs	Self-Study Courses
Credit Card Orders	Payment Inquiries	Shipping Information
IMEchE Publications	Professional Development	Subscriptions/Journals/Magazines
Meetings & Conferences	Short Courses	Symposia Volumes
Member Dues Status	Publications	Technical Papers

How can you reach us? It's easier than ever!

There are four options for making inquiries* or placing orders. Simply mail, phone, fax, or E-mail us and a Customer Care representative will handle your request.

<i>Mail</i>	<i>Call Toll Free</i>	<i>Fax—24 hours</i>	<i>E-Mail—24 hours</i>
ASME	US & Canada: 800-THE-ASME	973-882-1717	customercare@asme.org
150 Clove Road, 6th Floor	(800-843-2763)	973-882-5155	
Little Falls, New Jersey	Mexico: 95-800-THE-ASME		
07424-2139	(95-800-843-2763)		

*Customer Care staff are not permitted to answer inquiries about the technical content of this code or standard. Information as to whether or not technical inquiries are issued to this code or standard is shown on the copyright page. All technical inquiries must be submitted in writing to the staff secretary. Additional procedures for inquiries may be listed within.

ASME B30.5-2018

ISBN 978-0-7918-7191-1



9 780791 871911



J 0 8 3 1 8