



International
Labour
Office
Geneva

Safety and health in the use of machinery



**Safety and health
in the use of machinery**

ILO code of practice

Safety and health in the use of machinery

International Labour Office Geneva

Copyright © International Labour Organization 2013
First published 2013

Publications of the International Labour Office enjoy copyright under Protocol 2 of the Universal Copyright Convention. Nevertheless, short excerpts from them may be reproduced without authorization, on condition that the source is indicated. For rights of reproduction or translation, application should be made to ILO Publications (Rights and Permissions), International Labour Office, CH-1211 Geneva 22, Switzerland, or by email: pubdroit@ilo.org. The International Labour Office welcomes such applications.

Libraries, institutions and other users registered with reproduction rights organizations may make copies in accordance with the licences issued to them for this purpose. Visit www.ifro.org to find the reproduction rights organization in your country.

ILO

Safety and health in the use of machinery. ILO code of practice
Geneva, International Labour Office, Programme on Safety and Health at Work and the Environment, 2013

ISBN 978-92-2-127725-5 (print)

ISBN 978-92-2-127726-2 (web pdf)

occupational safety / occupational health / hazard / protective equipment / machinery / code of practice
13.04.2

Also available in French: *La sécurité et la santé dans l'utilisation des machines* (ISBN 978-92-2-227725-4), Geneva, 2013, and in Spanish: *Seguridad y salud en la utilización de la maquinaria* (ISBN 978-92-2-327725-3), Geneva, 2013.

ILO Cataloguing in Publication Data

The designations employed in ILO publications, which are in conformity with United Nations practice, and the presentation of material therein do not imply the expression of any opinion whatsoever on the part of the International Labour Office concerning the legal status of any country, area or territory or of its authorities, or concerning the delimitation of its frontiers.

The responsibility for opinions expressed in signed articles, studies and other contributions rests solely with their authors, and publication does not constitute an endorsement by the International Labour Office of the opinions expressed in them.

Reference to names of firms and commercial products and processes does not imply their endorsement by the International Labour Office, and any failure to mention a particular firm, commercial product or process is not a sign of disapproval.

ILO publications and electronic products can be obtained through major booksellers or ILO local offices in many countries, or direct from ILO Publications, International Labour Office, CH-1211 Geneva 22, Switzerland. Catalogues or lists of new publications are available free of charge from the above address, or by email: pubvente@ilo.org

Visit our website: www.ilo.org/publn

This publication was produced by the Document and Publications Production,
Printing and Distribution Branch (PRODOC) of the ILO.

*Graphic and typographic design, layout and composition, manuscript preparation,
copy editing, proofreading, printing, electronic publishing and distribution.*

PRODOC endeavours to use paper sourced from forests managed
in an environmentally sustainable and socially responsible manner.

Code: DTP-CAD-CORR-NOU-IMPR

Preface

This new ILO code of practice sets out principles concerning safety and health in the use of machinery and defines safety and health requirements and precautions applicable to governments, workers and employers, and also to designers, manufacturers and suppliers of machinery. Machinery is used in virtually all work activities, and thus presents certain safety and health risks in a large number of workplaces all over the world. Many new types of machinery are also introduced each year, hence the urgent need for a systematic approach to ensure safety and health when machinery is put on the market.

The ILO Global Strategy on Occupational Safety and Health adopted in 2003 called for the revision of the Guarding of Machinery Convention, 1963 (No. 119), and Recommendation (No. 118), and recommended that “Priority should also be given to the development of a new instrument on the guarding of machinery in the form of a code of practice”.

In response, the Governing Body of the International Labour Office, at its 306th Session (November 2009), took the decision to convene a meeting of experts to draw up a code of practice on safety and health in the use of machinery. The meeting was held in Geneva from 29 November to 7 December 2011. Eight experts appointed following consultations with governments, eight following consultations with the Employers’ group and eight following consultations with the Workers’ group of the Governing Body participated in the meeting. After examining and finalizing the text, based on a draft prepared by the Office, the experts adopted this code of practice. In view of the comprehensive needs of all the stakeholders, this new code covers a much broader scope in addition to the guarding of machinery.

The practical recommendations of this code of practice are intended for the use of all those who have a responsibility for safety and health

Safety and health in the use of machinery

in the use of machinery. The code is not intended to replace national laws, regulations or accepted standards. Its object is to provide guidance to those who may be engaged in the framing of provisions relating to the use of machinery at work, such as competent authorities and the management of companies where machinery is supplied or used. The code also offers guidelines to designers, manufacturers, suppliers and employers' and workers' organizations.

Local circumstances and the availability of financial and technical resources will determine the speed and extent of implementation. The provisions of this code should also be read in the context of the conditions in the country proposing to use the information. With this in mind, the needs of developing countries have been taken into consideration.

The text of the code was approved for publication by the Governing Body of the ILO at its 313th Session (March 2012).

List of participants

Chairperson

Ms R. Edwards, Regional Director, Midlands, Health and Safety Executive (United Kingdom)

Experts appointed after consultations with governments

Dr J. Basri, Director-General, Department of Occupational Safety and Health (Malaysia)

Adviser

Mr A. Yahya, Director, Department of Occupational Safety and Health (Malaysia)

Ms A. Becker, Auditora Fiscal do Trabalho, Ministerio do Trabalho e Emprego (Brazil)

Mr F. Boye, Acting Chief Inspector of Factories, Department of Factories Inspectorate (Ghana)

Mr J. Malatse, Director of Electrical and Mechanical Engineering, Department of Labour (South Africa)

Mr G. Mansour, Provincial Coordinator, Specialized Professional Services, Ontario Ministry of Labour (Canada)

Mr C. Maujean, Senior Officer, Coordination of Work Equipment Inquiries Standardization and Market Surveillance of Machinery (France)

Mr T. Mössner, Expert for Safety of Machinery and Mechanical Hazards, Federal Institute for Occupational Safety and Health (Germany)

Mr T. Saito, Senior Researcher, Mechanical Safety Researching Group, National Institute of Occupational Safety and Health (Japan)

Safety and health in the use of machinery

Experts appointed after consultations with the Employers' group

Mr J. Gallego Pérez, Engineer, Inversiones Mundial SA (Colombia)

Mr P. Jarvie, Occupational Health and Safety Manager, Employers and Manufacturers' Association (New Zealand)

Mr N. Kawaike, General Manager for Standardization Division, Japan Machinery Federation (Japan)

Mr N. Mphofu, Health and Safety Manager, Steel and Engineering Industry Federation of South Africa (South Africa)

Ms M. Nilsson, Expert and Adviser on Occupational Safety and Work Environment, the Association of Swedish Engineering Industries (Sweden)

Dr S. Sandrock, Researcher on Applied Ergonomics, Institut für angewandte Arbeitswissenschaft (Germany)

Mr L. Wong Moi Sang, Employers' Adviser, Mauritius Employers' Federation (Mauritius)

Mr U. Wortmann, EMEA HS&E Manager, Procter & Gamble (Belgium)

Experts appointed after consultations with the Workers' group

Ms J. Bodibe, Policy Coordinator on Occupational Health and Safety, Congress of South African Trade Unions (South Africa)

Mr M. Breidbach, Member of Global Health and Safety Committee, Coordinator EWC WG Health and Safety, IGM, Arcelor Mittal Bremen GmbH (Germany)

Mr N. Hosokawa, Japanese Electronic and Information Union (Japan)

List of participants

Ms F. Murie, Director of Health and Safety, Building and Woodworkers International (Switzerland)

Mr L. Carlos de Oliveira, Director of the Sindicato dos Metalúrgicos de São Paulo, and Director of Força Sindical (Brazil)

Mr S. Sallman, Safety and Health Specialist, United Steelworkers (United States)

Mr R. Sneddon, Community National Health and Safety Officer, The Grange (United Kingdom)

Ms D. Vallance, National OHS Coordinator, Australian Manufacturing Workers' Union (Australia)

International governmental and non-governmental organizations represented

World Health Organization (WHO): Dr Ivan D. Ivanov, Dr Evelyn Kortum; WHO Collaborating Centre for Occupational Health: Dr Vladimir Murashov

International Organisation of Employers (IOE): Dr Janet Asherson

International Trade Union Confederation (ITUC): Ms Esther Busser

ILO secretariat

Mr Seiji Machida, Director – Programme on Safety and Health at Work and the Environment (SafeWork)

Dr Tsuyoshi Kawakami, Coordinator, Occupational Safety, Policy and Management Systems Cluster – Programme on Safety and Health at Work and the Environment (SafeWork)

Dr Shengli Niu, Coordinator and Senior Specialist, Occupational Health Cluster – Programme on Safety and Health at Work and the Environment (SafeWork)

Safety and health in the use of machinery

Mr Pavan Baichoo, Technical Specialist, Occupational Safety, Policy and Management Systems Cluster – Programme on Safety and Health at Work and the Environment (SafeWork)

Dr Marie-Louise Riley-Roberts, ILO Consultant, Health and Safety Executive (United Kingdom)

Ms Tuiri Kerttula, ILO Consultant, Finnish Safety and Chemicals Agency (Tukes) (Finland)

Contents

Preface	V
List of participants	VII
Introduction	1
Part I. General requirements	5
1. General provisions	7
1.1. Scope and application	7
1.2. Objectives	7
1.3. Hierarchy of controls	8
1.4. Definitions	8
2. General obligations, responsibilities and duties	12
2.1. Roles and obligations of the competent authority	12
2.2. General responsibilities of designers and manufacturers	14
2.3. General responsibilities of suppliers	22
2.4. General responsibilities of employers	22
2.5. Worker participation	39
2.6. Cooperation	41
Part II. Technical requirements and specific measures	43
3. General statements on the working environment	45
3.1. Materials and products	45
3.2. Lighting	45
3.3. Design of machinery to facilitate its handling	46
3.4. Ergonomics	47
3.5. Operating positions	50
3.6. Seating	50

Safety and health in the use of machinery

4. Control systems	52
4.1. Safety and reliability of control systems	52
4.2. Control devices	53
4.3. Starting	55
4.4. Stopping	56
4.5. Failure of the energy source	59
5. Machinery guarding and protection against mechanical hazards	60
5.1. Risk of loss of stability	60
5.2. Risk of break-up during operation	60
5.3. Risks due to falling or ejected objects	61
5.4. Risks due to surfaces, edges or angles	61
5.5. Risks related to combined machinery	61
5.6. Risks related to variations in operating conditions	61
5.7. Risks related to moving parts	62
5.8. Choice of protection against risks arising from moving parts	62
5.9. Moving transmission parts	63
5.10. Moving parts involved in the process	63
5.11. Risks of uncontrolled movements	64
5.12. General requirements for guards	64
5.13. Special requirements for guards	65
5.14. Adjustable guards restricting access	66
5.15. Special requirements for protective devices	66
6. Machinery guarding and protection against other hazards	67
6.1. Electricity supply	67
6.2. Static electricity	67
6.3. Energy supply other than electricity	67
6.4. Errors in fitting	67

Contents

6.5.	Extreme temperatures	68
6.6.	Effect of climate	68
6.7.	Fire	69
6.8.	Explosion	69
6.9.	Noise	69
6.10.	Vibration	71
6.11.	Ionizing and non-ionizing radiation arising from the machinery	72
6.12.	External radiation	73
6.13.	Laser radiation	73
6.14.	Emissions of hazardous materials and substances	74
6.15.	Risk of being trapped in machinery	74
6.16.	Risk of slipping, tripping or falling	75
6.17.	Lightning	75
6.18.	Access to operating positions and servicing points	75
6.19.	Isolation of energy sources	75
6.20.	Worker intervention	76
6.21.	Cleaning of internal parts	76
7.	Information and marking	77
7.1.	Information and information devices	77
7.2.	Warning devices	77
7.3.	Warning of residual risks	77
7.4.	Marking of machinery	78
8.	Supplementary measures relating to specific machinery types	79
8.1.	Portable hand-held and hand-guided machinery (such as chainsaws, hedge trimmers, cartridge- operated tools, grinders, etc.)	79
8.2.	Portable impact fixing machinery (pneumatic and explosive cartridge activated)	80

Safety and health in the use of machinery

8.3. Machinery for working wood and material with similar physical characteristics (such as circular saws, band saws, planing and thickening machinery)	80
8.4. Machinery presenting hazards due to its mobility (such as vehicles, earth-moving machinery, excavators, harvesters and tractors)	81
8.5. Lifting machinery (such as cranes and hoists)	82
8.6. Machinery for the lifting of persons	84

Bibliography

85

Appendices

91

I. Types of different guarding for machinery	92
II. Detailed supplementary technical information for certain specific machinery types	101
III. Example of a lathe as a prompt to assist in the risk assessment process for any machinery	129
IV. Generic risk assessment template	130
V. Ergonomic risk assessment template	134

Introduction

This code of practice is based on principles established in international instruments relevant to the protection of workers' safety and health. It is intended to provide guidance on safety and health in the use of machinery in the workplace. Worker safety and health should be addressed from design to decommissioning of machinery (figure 1).

Figure 1. Division of responsibilities for ensuring safety in the use of machinery during its life cycle

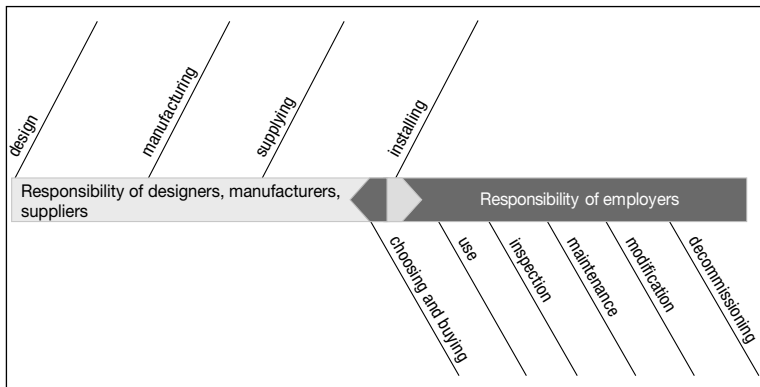

Part I of the code sets out the scope, objectives, hierarchy of controls and definitions, as well as the general obligations, responsibilities and duties of the competent authority, designers and manufacturers, suppliers and employers, workers and their organizations. Part II deals with technical requirements and specific measures that should be taken in order to protect workers' safety and health. The relevant sections of this part should be used by manufacturers and suppliers to ensure that machinery is designed and constructed in such a way that it is safe

Safety and health in the use of machinery

for use and fits the purpose for which it is intended. The relevant sections should be used by employers to assess whether machinery they select and use or modify is fit for purpose and suitable for the specific working environment and conditions. Part II includes chapters on general statements, control systems, machinery guarding and protection against mechanical and other hazards, information, including marking and supplementary measures relating to specific machinery types.

The appendices provide more specific information for manufacturers, suppliers and employers to supplement Parts I and II. They include information on types of different guarding for machinery and detailed supplementary technical information for certain specific machinery types. The information in the appendices is intended to be informative and provide more detailed guidance to assist designers and manufacturers and employers. Because the state of the art may change over time, enabling more effective measures to be provided, designers and manufacturers and employers should always refer to current specific guidance, starting with the references indicated in the bibliography of this code, for example.

The application of the code at the national and enterprise levels should be pursued as part of comprehensive occupational safety and health (OSH) programmes and systems, seeking further guidance from relevant ILO instruments, in particular the Occupational Safety and Health Convention, 1981 (No. 155), the Occupational Safety and Health Recommendation, 1981 (No. 164), the Protocol of 2002 to the Occupational Safety and Health Convention, the Promotional Framework for Occupational Safety and Health Convention, 2006 (No. 187), the Promotional Framework for Occupational Safety and Health Recommendation, 2006 (No. 197), and the *Guidelines on Occupational Safety and Health Management Systems (ILO–OSH 2001)*, as well as other ILO instruments and codes of practice listed in the bibliography.

The practical recommendations of ILO codes of practice are intended for the use of all those, in both the public and private sectors, who have responsibility for safety and health management. Codes of practice are not intended to replace national laws or regulations or accepted standards. They are drawn up with the objective of providing guidance, in accordance with the provisions of national laws and regulations, to all those who may be engaged, through social dialogue, in the framing of provisions of this kind or in elaborating programmes of prevention and protection at the national or enterprise level. They are addressed in particular to governmental and public authorities, employers and workers and their organizations, as well as management and safety and health committees in related enterprises.

The provisions of this code of practice should be read in the context of the conditions in the country proposing to use the guidance it contains, the scale of operation involved and technical possibilities. In this regard, the needs of developing countries are also taken into consideration.

PART I. GENERAL REQUIREMENTS

1. General provisions

1.1. Scope and application

1.1.1. This code applies to any work activity in which machinery is used.

1.1.2. The code is intended to apply generally to the design, manufacture, supply and use of machinery for use at work. It does not take into account the particular specificities relating to certain categories of machinery, such as weapons, pressure vessels, medical devices, seagoing vessels, vehicles and trailers solely for transportation of passengers by rail, road, air or water, machinery for military use and household appliances for domestic use, which are typically covered by special legislation at the national level.

1.1.3. This code applies to all stages of the life cycle of the machinery, including second-hand, rebuilt, modified or redeployed machinery for use at work.

1.2. Objectives

1.2.1. The objective of this code is to protect workers from the hazards of machinery and to prevent accidents, incidents and ill health resulting from the use of machinery at work by providing guidelines for:

- (a) ensuring that all machinery for use at work is designed and manufactured to eliminate or minimize the hazards associated with its use;
- (b) ensuring that employers are provided with a mechanism for obtaining from their suppliers necessary and sufficient safety information about machinery to enable them to implement effective protective measures for workers; and

Safety and health in the use of machinery

- (c) ensuring that proper workplace safety and health measures are implemented to identify, eliminate, prevent and control risks arising from the use of machinery.

1.3. Hierarchy of controls

1.3.1. Unless a particular hazard is removed, the risk associated with such a hazard can never be completely eliminated.

1.3.2. The approach most commonly used is referred to as the hierarchy of controls, from preferred to least desirable, as follows:

- (a) elimination;
- (b) substitution;
- (c) engineering controls;
- (d) administrative (procedural) controls; and
- (e) personal protective equipment (PPE).

1.4. Definitions

1.4.1. The following definitions apply for the purposes of this code:

- *Competent authority*: A minister, government department or other public authority with the power to issue regulations, orders or other instructions having the force of law.
- *Competent person*: A person with suitable training and sufficient knowledge, experience and skill for the safe performance of the work in question. The competent authority may define appropriate criteria for designating such persons and may determine the duties to be assigned to them.
- *Dangerous occurrence*: Readily identifiable event, as defined under national laws and regulations, with potential to cause injury

General provisions

- or disease to people at work or the general public, for example a “near miss” or a “near hit”.
- *Employer*: Any physical or legal person that employs one or more workers.
 - *Fault tolerance*: Ability of a functional unit to continue to perform a required function in the presence of faults or errors.
 - *Guard*: A part of machinery specifically designed to provide protection by means of a physical barrier.
 - *Hazard*: The inherent potential to cause injury or damage to people’s health.
 - *Incident*: An unsafe occurrence arising out of or in the course of work where no personal injury is caused.
 - *Life cycle*: All phases of the life of machinery, i.e.:
 - (a) transport, assembly and installation;
 - (b) commissioning;
 - (c) use; and
 - (d) decommissioning, dismantling and disposal.
 - *Machinery*: An assembly fitted with, or intended to be fitted with, a drive system other than one using only directly applied human or animal effort, consisting of linked parts or components, at least one of which moves, and which are joined together for a specific application.
 - *Maintenance*: Workplace activities such as constructing, installing, setting up, testing, adjusting, inspecting, modifying, and maintaining machinery on a preventive, periodic and predictive basis. These activities include lubrication, cleaning or unjamming

Safety and health in the use of machinery

of machinery and making adjustments or tool changes where a worker may be exposed to the unexpected energization or start-up of the machinery or release of hazardous stored energy.

- *Manufacturers*: Any natural or legal persons responsible for marketing machinery under their names or trademarks, whether they actually design and manufacture the machinery themselves or contract those tasks to a third party. This includes cases in which the machinery is manufactured exclusively for their use.
- *OSH management system*: A set of interrelated or interacting elements to establish occupational safety and health (OSH) policy and objectives, and to achieve those objectives.
- *Protective device*: A safeguard other than a guard which reduces risk, either alone or in conjunction with a guard.
- *Risk*: A combination of the likelihood of an occurrence of a hazardous event and the severity of injury or damage to health of workers caused by this event.
- *Risk assessment*: The process of evaluating the risks to safety and health arising from hazards at work.
- *Safety and health committee*: A committee with representation of workers' safety and health representatives and employers' representatives established and functioning at organization level according to national laws, regulations and practice.
- *Supplier*: Any natural or legal person in the supply chain, including the manufacturer, importer and distributor, who makes the machinery available, including second-hand machinery.
- *Worker*: Any person who performs work, either regularly or temporarily, for an employer.

General provisions

- *Workers' representative:* In accordance with the Workers' Representatives Convention, 1971 (No. 135), any person who is recognized as such by national law or practice, whether they are:
 - (a) trade union representatives, namely, representatives designated or elected by trade unions or by members of such unions; or
 - (b) elected representatives, namely, representatives who are freely elected by the workers of the organization in accordance with provisions of national laws or regulations or of collective agreements and whose functions do not include activities which are recognized as the exclusive prerogative of trade unions in the country concerned.

2. General obligations, responsibilities and duties

2.1. Roles and obligations of the competent authority

2.1.1. The competent authority should formulate, implement and periodically review a coherent national policy on safety in the use of machinery, taking into account national conditions and practice and in consultation with the most representative organizations of employers and workers concerned.

2.1.2. Such a policy should take due account of relevant international regulations, standards and systems, including the guidance contained in this code of practice.

2.1.3. The competent authority should establish and from time to time review laws, regulations and standards for safety in the use of machinery, in consultation with the most representative organizations of employers and workers concerned, and relevant professional bodies.

2.1.4. The competent authority should establish mechanisms to ensure compliance with national laws and regulations. These should include an adequate and appropriate system of risk-based inspection. The system of enforcement should provide for corrective measures and adequate penalties for violations of national laws and regulations concerning the policy.

2.1.5. On safety and health grounds, the competent authority may justifiably:

- (a) prohibit or restrict the use of hazardous machinery;
- (b) specify qualifications of workers who, for reasons of safety and health, are allowed to use specific machinery, or are allowed to use them but only under conditions prescribed in accordance with national laws and regulations.

General obligations, responsibilities and duties

2.1.6. The competent authority should, where appropriate, require designers, manufacturers and suppliers to provide it with safety and health-related information on the assessment of the hazards and risks associated with machinery.

2.1.7. The competent authority should ensure that guidance is provided to employers, workers and their representatives to help them comply with their legal obligations under the policy. The competent authority should provide assistance to employers, workers and their representatives with respect to their OSH responsibilities, obligations and rights.

2.1.8. The competent authority should ensure that machinery on the market satisfies the legal OSH requirements.

2.1.9. The competent authority should endeavour to promote close cooperation between designers, manufacturers, suppliers, employers, workers and their representatives on safety and health in the use of machinery.

2.1.10. The competent authority should establish, apply, and periodically review a system for the recording and notification by employers of occupational accidents, occupational diseases and dangerous occurrences caused by machinery.

2.1.11. The competent authority should have a system for investigating occupational accidents, diseases and dangerous occurrences as appropriate. Such investigations should make use of relevant reports and other available information.

2.1.12. The competent authority should, in accordance with national law and practice:

- (a) periodically carry out inspections and monitor compliance with relevant laws and regulations in the use of machinery;

Safety and health in the use of machinery

- (b) inform employers, workers and their representatives of the findings of inspections for the implementation of required remedial action;
- (c) have the authority to issue an order to stop the use of machinery in situations where there is an imminent or serious danger to the safety or health of workers; and
- (d) produce and update safety guidance, where appropriate, in co-operation with the representative organizations of employers and workers.

2.1.13. The competent authority should have sufficient human and financial resources to fulfil its responsibilities. Systems should be in place to ensure that its staff are competent to deal with the OSH issues associated with machinery and are able to provide appropriate support and advice.

2.1.14. The authority, rights and responsibilities of inspectors should be established and publicized.

2.2. General responsibilities of designers and manufacturers

2.2.1. Machinery should be designed to be inherently safe so that hazards are eliminated. Where this is not possible, manufacturers and designers should ensure that adequate technical protective measures are provided, so that safety and health risks are reduced to the lowest practical level, using the hierarchy of controls and referring in particular to section 3.4 for aspects relating to ergonomics.

2.2.2. Manufacturers should ensure that the machinery they produce fulfils the safety requirements of applicable laws and regulations.

2.2.3. Manufacturers should ensure that the relevant certification, markings or documentation are available in accordance with national law and practice.

General obligations, responsibilities and duties

2.2.4. Manufacturers should provide instructions for installation and use of the machinery, including the information needed by the employer, operator and users of the machinery for its safe operation and maintenance.

2.2.5. Manufacturers of machinery should monitor and study any reports of malfunctions, dangerous occurrences and accidents and diseases involving the actual machinery in question or similar machinery, and any remedial measures that have been taken to control unacceptable risks that have been identified, in order to prevent recurrences. Manufacturers and designers should use the collected information on accidents and diseases to improve the safety of machinery. Manufacturers should inform designers and customers of serious defects which affect safety and health they have identified in the design or use of the machinery and the action they should take. This action could include product recall.

2.2.6. When designing machinery, the manufacturer should carry out an iterative process of risk assessment and risk reduction as part of the design process.

2.2.7. By the iterative process of risk assessment and risk reduction (see figures 2 to 4) referred to in 2.2.6, the manufacturer should:

- (a) determine the full range of uses to which the machinery may be put, which should include both the intended use and any reasonably foreseeable misuse;
- (b) with reference to (a), identify the hazards or hazardous situations which the use or misuse of such machinery may present;
- (c) eliminate any hazards as far as is reasonably practicable;
- (d) estimate the risks, taking into account the severity of a possible injury or damage to health and the probability of its occurrence;

Safety and health in the use of machinery

- (e) evaluate whether the risk level is adequately controlled with a view to determining whether risk reduction is required; and
- (f) reduce the risks identified in (e) by the application of protective measures.

2.2.8. Manufacturers should ensure that machinery they produce for the workplace complies with the requirements set out in the relevant sections of Part II of this code, or other corresponding international or national standards and recommendations, taking into account the state of the art;¹ if it is not possible to meet those requirements, the machinery should be designed and constructed with the aim of approaching those requirements as closely as possible.

2.2.9. Manufacturers should ensure that machinery is designed and constructed in such a way that it fits the purpose for which it is intended. It should be operated, adjusted and maintained without putting persons at risk during its operation under foreseeable conditions, but also taking into account any reasonably foreseeable misuse.

2.2.10. Manufacturers should ensure in the design process that consideration is given to measures for eliminating or reducing any reasonably foreseeable risk during transporting, installing, dismantling, disabling and scrapping of machinery.

2.2.11. Manufacturers should ensure that machinery is designed and constructed to take into account possible constraints to which the operator may be subject as a result of the necessary or anticipated use of personal protective equipment (PPE).

¹ “State of the art” refers to the concept whereby manufacturers and suppliers must use the most effective technical means available at the time at a cost which is reasonable taking account of the total cost of the category of machinery concerned and the risk reduction required. The state of the art evolves when more effective means become available or when their cost diminishes, so that the technical solution that may have been appropriate at a given time may be considered inadequate later.

General obligations, responsibilities and duties

Figure 2. Iterative risk assessment and reduction process

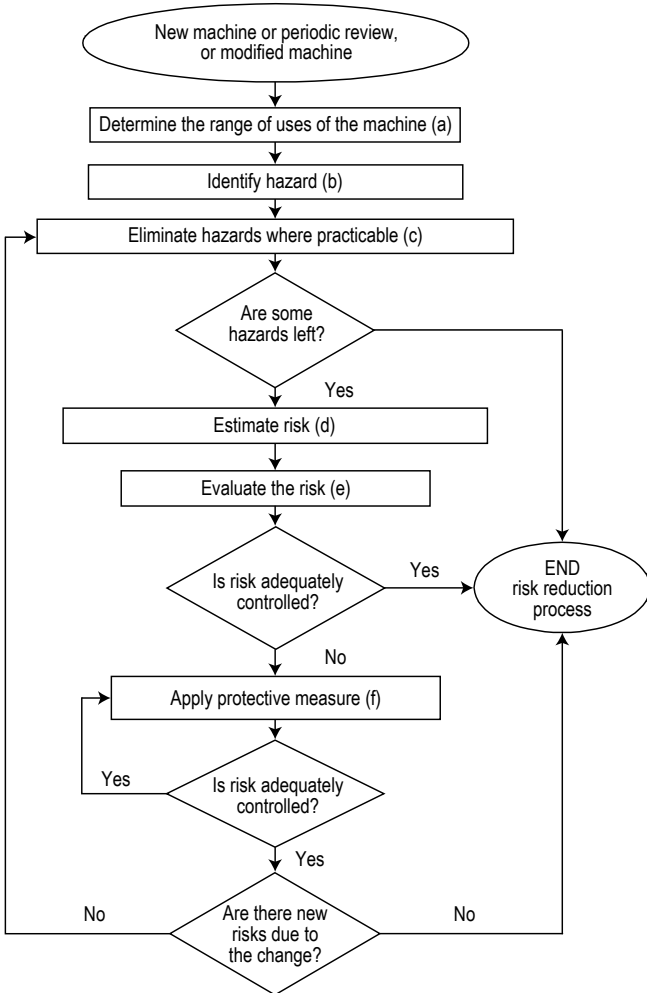

Safety and health in the use of machinery

Figure 3. Example of the iterative risk assessment and reduction process for machinery involving flammable fluid where the hazard can be eliminated

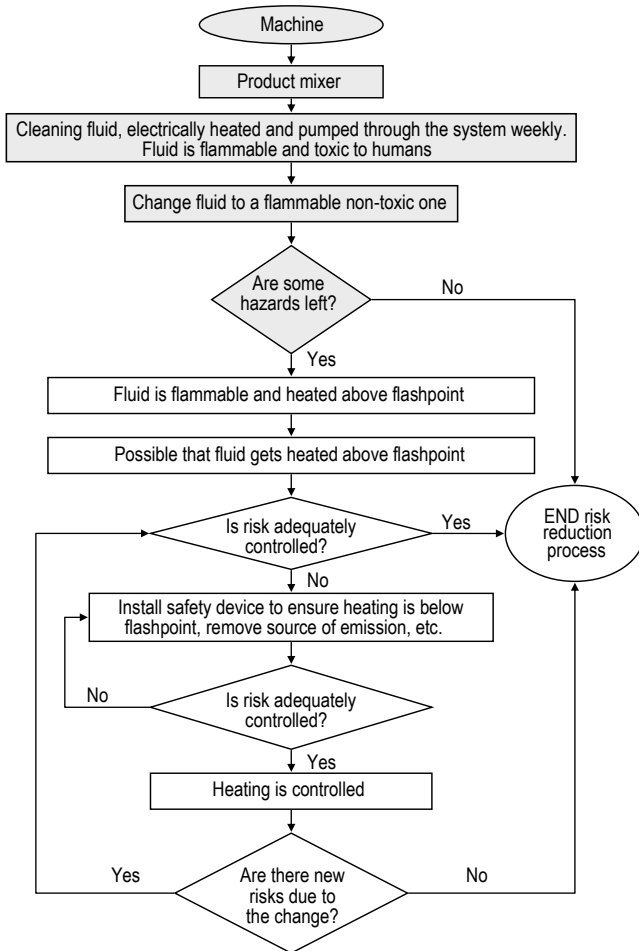

General obligations, responsibilities and duties

Figure 4. Example of the iterative risk assessment and reduction process for a power concrete saw where the hazard cannot be eliminated but is controlled

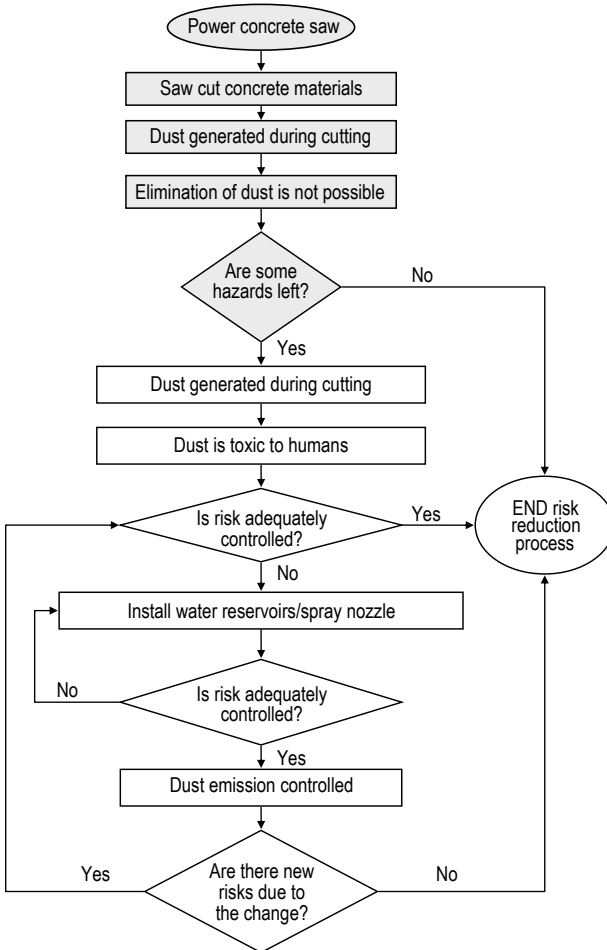

Safety and health in the use of machinery

2.2.12. Manufacturers should ensure that machinery is supplied with all the special equipment and accessories essential to enable it to be adjusted, maintained and used safely.

2.2.13. In accordance with national law and practice, manufacturers should mark and label machinery visibly, legibly and indelibly with any information and warnings that are essential for its safe use. Information and warnings on the machinery should preferably be provided in the form of readily understandable symbols or pictograms.

2.2.14. Instructions

2.2.14.1. Manufacturers of machinery should provide instructions for the safe use of the machinery they have manufactured. Each instruction manual or other written instructions (for example, on the packaging) should contain at least the following information:

- (a) the business name and full address of the manufacturer;
- (b) the make and model of the machinery;
- (c) the drawings, diagrams, descriptions and explanations necessary for the safe use, maintenance and repair of the machinery, as well as for checking that it is functioning correctly;
- (d) a description of the intended use of the machinery;
- (e) warnings indicating foreseeable ways in which the machinery should not be used;
- (f) assembly, installation and connection instructions;
- (g) instructions for reducing noise or vibration;
- (h) instructions for servicing and putting the machinery into use and, if necessary, instructions for training operators;

General obligations, responsibilities and duties

- (i) information about any residual risks that remain, despite inherently safe design measures, safeguarding and complementary protective measures adopted;
- (j) instructions for users on protective measures to be adopted, including, where appropriate, PPE to be provided;
- (k) the essential characteristics of tools which may be fitted to the machinery;
- (l) the conditions in which the machinery meets the requirement of stability during use, transportation, assembly, dismantling when out of service, testing or foreseeable breakdowns;
- (m) instructions to ensure that transportation, handling and storage can be effected safely;
- (n) operating instructions that are to be followed in the event of an accident or breakdown or, if a blockage is likely to occur, details of the procedure for safely unblocking the equipment;
- (o) the description of the setting up, adjustment and maintenance operations that should be carried out by the user and the preventive maintenance measures that should be applied;
- (p) instructions designed to enable adjustment and maintenance to be carried out safely, including the protective measures that should be taken during these operations;
- (q) the specifications of the spare parts to be used, when these may affect the safety and health of workers or others in the vicinity;
- (r) data on exposures generated by the machinery with regard to noise, vibration, radiation, gases, vapours and dust, where these may affect the safety and health of workers or others in the vicinity; and

Safety and health in the use of machinery

- (s) explanations of any information and warnings provided on the machinery in the form of symbols or pictograms.

2.3. General responsibilities of suppliers

2.3.1. Suppliers of machinery, including second-hand machinery, should ensure that machinery they supply:

- (a) fulfils the safety requirements of the country or market in which the machinery is put into service; and
- (b) is accompanied by instructions for use in the language or languages of the country or market in which it is put into service.

2.3.2. Suppliers should ensure that the machinery they supply is marked in accordance with the relevant national law and practice in force where the machinery is used.

2.3.3. Suppliers should ensure that relevant new OSH information that becomes available for the machinery they supply is passed on to their customers where practical.

2.3.4. Where suppliers assemble machinery prior to or on delivery, they should ensure that guards and protective devices are not damaged or missing.

2.3.5. When second-hand machinery is sold, suppliers should ensure that the machinery is safe and meets the technical requirements set out in this code, and national laws and regulations in the country to which it is being supplied.

2.4. General responsibilities of employers

2.4.1. Occupational safety and health policy and organization

2.4.1.1. Employers, in consultation with workers and their representatives, should set out in writing an OSH policy, and ensure that

General obligations, responsibilities and duties

workers and their representatives are consulted and encouraged to participate actively in all elements of the OSH management system, including their arrangements for the safe use of machinery.

2.4.1.2. Employers should implement an appropriate management system to control risks generated by the use of machinery and arrange for competent persons to be in charge of the following tasks:

- (a) implementation of technical measures to protect workers when using machinery;
- (b) establishment, maintenance and review of safe working procedures; and
- (c) investigation of the causes of machinery-related accidents and disease at the workplace and evaluation of measures to avoid recurrences.

2.4.1.3. The investigation of the origin and underlying causes of work-related injuries, ill health, diseases and incidents should identify any failures in the OSH management of machinery and should be documented.

2.4.1.4. The results of such investigations should be communicated to the safety and health committee, where it exists, and the committee should make appropriate recommendations.

2.4.1.5. The results of investigations, in addition to any recommendations from the safety and health committee, should be communicated to appropriate persons for corrective action, included in the management review and considered for continual improvement activities.

2.4.1.6. Whenever two or more employers are undertaking activities at the same workplace, they should cooperate in applying the provisions of this code, without prejudice to the responsibility of each employer for the safety and health of workers in his or her employment.

Safety and health in the use of machinery

2.4.2. Buying and selecting machinery

2.4.2.1. Machinery should only be selected after carefully taking into account all factors affecting OSH and working conditions, in addition to economic and technical criteria.

2.4.2.2. Employers should buy machinery for use in the workplace only if it complies with national laws and regulations and relevant international standards.

2.4.2.3. In selecting machinery, employers should ensure that they select machinery that is fit for the purpose and suitable for the specific working conditions concerned. This should be undertaken, as appropriate, in consultation with workers and their representatives.

2.4.2.4. When second-hand machinery is introduced at the workplace, employers should ensure that it is safe and meets the technical requirements determined by national laws and regulations.

2.4.3. Inspection of machinery

2.4.3.1. Employers should ensure that, where the safety of machinery depends on the installation, it should be subject to an initial inspection (after installation and before first being put into service). It should be inspected if moved to a new site or location.

2.4.3.2. Employers should ensure that machinery is safe through regular inspection by a competent person.

2.4.3.3. Inspections of hazardous machinery, as determined by national legislation, should be carried out only by persons familiar with the construction of the machinery, and capable of noticing any faults and determining their effects on safety and health. The qualifications of the competent persons, as well as the periodicity of inspections, should be determined in accordance with national law and practice.

General obligations, responsibilities and duties

2.4.3.4. Employers should ensure that machinery exposed to exceptional conditions such as accidents, adverse natural phenomena or prolonged periods of inactivity likely to affect the safety of the machinery, is subject to special inspections by competent persons in accordance with national law and practice.

2.4.3.5. The results of inspections should, where appropriate, be recorded by the employer and used for improving safety in the use of machinery. The record should be kept for a suitable period of time.

2.4.3.6. When machinery is hired or moved around from one workplace to another and, where there are national requirements to that effect, it should be accompanied by relevant documentation indicating that a recent inspection has been carried out.

2.4.3.7. The manner in which inspections are to be carried out by the competent person should be consistent with national laws and regulations. During an inspection the manufacturer's instructions for inspections should be taken into due account.

2.4.4. Risk assessment and risk reduction

Risk assessment and reduction process for employers

1. Introduction

1.1. Risk assessment is the process of evaluating the risks to safety and health arising from hazards at work. Risk is a combination of two factors: the **likelihood** that a given hazardous event will occur, and the likely **severity** of the consequences if it does occur. The objective of risk assessments is to develop a common ground of understanding of the hazard and its associated risks among workers involved in each stage of the life cycle of machinery.

Safety and health in the use of machinery

2. General requirements

2.1. In ensuring safety in the use of machinery by reducing the associated risks, risk assessments should be conducted at various levels. Risk assessment should be completed by employers to ensure that the machinery is safe and to provide a safe system of work, and workers should be consulted to reflect their views and experiences, and should actively participate in the risk assessment procedures.

2.2. Risk assessments are an iterative process (see Appendices IV and V for risk assessment templates that provide a preliminary approach, and Appendix III for an example of a machine (in this case, a lathe) to assist in the risk assessment process). When each new protective measure is put in place, a risk assessment should be carried out to ensure that it does not introduce a new hazard.

3. Outline of the risk assessment procedure

3.1. Safety and health risks can be assessed in five steps as follows:

- (1) collecting the appropriate information and determining the limits of the machinery, such as use, speed, time, environmental and interface limits;
- (2) identifying and documenting the hazards associated with the tasks to be performed for the use and maintenance of machinery in the workplace;
- (3) assessing risks arising from hazards by estimating the likelihood and severity of consequences and deciding whether the risks are adequately controlled;
- (4) planning actions to eliminate or reduce risk; and
- (5) documenting risk assessment results.

3.2. Risk assessments to ensure safety in the use of machinery should cover the following seven aspects:

- (a) adequacy of initial machinery design;
- (b) correct selection of machinery;
- (c) adequacy of machinery installation;
- (d) correct use;
- (e) adequate maintenance;
- (f) managing changes in personnel, materials and work methods; and
- (g) equipment and process modifications.

3.3. Employers should consider the persons affected when identifying tasks and hazards. These may include: operators and helpers, maintenance individuals, engineers, technicians, sales personnel, installation and removal personnel, administrative personnel, trainees, passers-by, designers, managers, supervisors, safety personnel, safety committees, safety consultants, and loss control administrators. In addition, employers should determine the level of knowledge, training, experience and ability of these people.

3.4. Risks should be analysed by: (1) identifying factors affecting the hazard and the severity of potential consequences; (2) evaluating effectiveness of existing controls; (3) estimating the likelihood of the possible consequences, considering exposure and hazard levels; and (4) combining the above to obtain a level of risk and to prioritize the risk for action.

3.5. Typical categories of hazards and hazardous situations include (see also Part II): (1) mechanical; (2) electrical; (3) thermal;

Safety and health in the use of machinery

(4) noise; (5) vibration; (6) radiation; (7) materials and substances; (8) ergonomic; (9) unexpected start-up, overrun and overspeed; (10) inadequate stopping; (11) rotating parts; (12) power supply failure; (13) control circuit failure; (14) errors of fitting; (15) break-up during operation; (16) falling or ejected objects or fluids; (17) loss of stability and overturning of machinery; (18) slipping, tripping and falling; and (19) combinations of the above.

3.6. There are many established methods and techniques for carrying out risk assessments. Some use a numerical weighting system to determine priorities for action. For each hazard identified, a numerical value is assigned to the likelihood of the hazard causing harm, as well as to the severity of the consequences. This can be expressed on a rising scale from low to high as follows:

Likelihood:

- (1) rare: has rarely if ever happened;
- (2) unlikely: is possible, but is not expected to happen;
- (3) possible: could be expected to happen once a year;
- (4) likely: will probably occur, but is not persistent;
- (5) almost certain: occurs regularly.

Severity:

- (1) insignificant: no injury or ill health;
- (2) minor: short-term impact;
- (3) moderate: semi-permanent injury or ill health;
- (4) major: disabling injury or ill health;
- (5) catastrophic: potentially fatal.

3.7. The degree of risk can be represented in the following manner: Risk = Severity \times Likelihood.

3.8. By determining the level of risk associated with each hazard identified in the working environment, employers and workers and their representatives can identify areas for priority action. For example, a risk that rarely arises (1) and has insignificant consequences (1) would have the lowest priority (1) (i.e. $1 \times 1 = 1$), whereas a hazardous event that occurs regularly (5) and has potentially fatal consequences (5) would have the highest priority for action (25) (i.e. $5 \times 5 = 25$). The higher the level of risk, the more important it is to apply controls that eliminate, reduce or minimize exposure to the hazard.

3.9. All tasks associated with the machinery should be identified (task analysis). Examples of task categories include: packing and transportation, unloading and unpacking, systems installation, start-up and commissioning, set up and try out, operation in all modes, tool change, planned maintenance, unplanned maintenance, major repair, recovery from control failure, recovery from jamming, troubleshooting, housekeeping, decommissioning and disposal.

4. Risk control

4.1 Three main criteria for evaluating the effectiveness of risk control can be used: the hierarchy of controls; legislation and standards; and the effectiveness of monitoring processes.

4.2. The hierarchy of controls gives the priority order in which hazard and risk controls should be considered. The prime emphasis is on: (1) elimination of the hazard; where that is not practicable, minimization of risk by: (2) substitution with less hazardous materials and substances; (3) engineering controls, such as safeguards and

Safety and health in the use of machinery

machinery control techniques; (4) administrative controls, including appropriate procedures, training and systems of work; and (5) use of personal protective equipment (PPE).

4.3. As regards legislation and standards, factors that should be considered are whether: (1) the law is satisfied (hazard-specific legislation may require specific risk control actions); (2) the controls meet or exceed industry standards; and (3) the controls take account of currently available knowledge.

4.4. As regards monitoring processes, the following questions should be considered by employers: (1) Are support systems and management processes in place? (2) Are they effective and reliable in ensuring that suitable protective measures are implemented and maintained? (3) Are they effective in warning when protective measures may be deteriorating or failing? (4) Are the warnings acted upon? and (5) What systems are in place to decide and implement adequate modification?

5. Maintaining and documenting risk control processes

5.1. It is important to establish and maintain a risk register and keep key documents relating to risk management, as this enables suppliers and employers to track the status of hazards and risks. The key documents include: a list of hazards, their location and people exposed; a range of scenarios under which these hazards may cause injury; the nature of any damage or injury that may be caused; and the results of the risk assessment.

5.2. Documentation of the risk assessment and the risk reduction process should demonstrate the procedure that has been followed and the results that have been achieved. The supplier should provide documentation on significant hazards, protective measures

taken, any residual risks, and recommendations for additional protective measures to be implemented by the employer in the use of the machinery. Employers' documentation should include the protective measures adopted and the resulting residual risks in the workplace.

5.3. It is equally important to document and communicate risk management procedures, since documented procedures are essential if there is to be a common understanding of how things should be done and risks controlled. Employers, workers and others should participate effectively in safety and health risk management, be aware of the procedures and have the necessary knowledge and skills to contribute.

2.4.4.1. Before the machinery is put into service, employers should be sure that they understand all the instructions provided. On the basis of that information, they should assess the risks arising from actual situations in which the machinery is used, taking into account work materials, the placement of the machinery in the work area, operating procedures, organization of work at the workplace, workers' capabilities and the overall working environment. This should be done in consultation with the workers concerned and their representatives.

2.4.4.2. Employers should ensure that the machinery they use complies with the requirements set out in relevant sections of Part II of this code, or other corresponding international or national standards and recommendations, taking into account the state of the art; if it is not possible to meet those requirements, the machinery should be adapted with the aim of approaching those requirements as closely as possible.

2.4.4.3. Employers should reassess the risks arising from the use of existing machinery periodically, whenever modifications are

Safety and health in the use of machinery

made, or if work conditions change significantly, taking into account the information provided by the manufacturer and supplier. Where such information is not available, employers should seek information from other relevant sources. This information should be used to complete the risk assessment process with a view to protecting workers by appropriate preventive measures.

2.4.4.4. Employers should take appropriate measures to protect workers against the risks identified by the assessment referred to in 2.4.4.1 and 2.4.4.2. First, hazards should be eliminated by technical means such as substitution of hazardous materials. Where this is not possible, the employer should ensure that safety and health issues are managed through technical measures such as engineering controls, layout design, barriers, upgraded guards and protective devices, ventilation, noise enclosure and ergonomic solutions. If that is not possible, the safety of workers should be ensured, where appropriate, through training and safe systems of work and supervision and, where residual hazards cannot be controlled by these measures, through the use of PPE, backed up by appropriate safety information and signs.

2.4.4.5. Where PPE is necessary to protect the safety and health of workers, it should be fit-for-purpose, suited to the individual and provided at no cost to workers. The employer should implement measures to ensure that it is available, used and stored and maintained safely and in good working order. Workers should be consulted in its selection and trained in its use.

2.4.4.6. The employer should continuously monitor the safety of the machinery, including any changes in the working environment and organization of work; where changes are found to have occurred, a new risk assessment may be necessary.

2.4.4.7. The employer should undertake an ergonomic risk assessment (see Appendix V) of machinery use to ensure that the safety and

General obligations, responsibilities and duties

health protection of workers is optimized during the work task process. The main factors to be addressed include:

- (a) characteristics of the working environment and its impact on workers;
- (b) equipment/workstation overall design and flow-through;
- (c) the weight of the product or tools being handled;
- (d) the frequency of handling products, tools and applying force;
- (e) the duration in which products or tools are handled or force is applied;
- (f) the postures adopted by workers when handling the materials/products or applying the force; and
- (g) the physical characteristics of workers when carrying out their activities (height, build, gender and age).

2.4.4.8. Investigations of the origin and underlying causes of work-related injuries, ill health, diseases and incidents should identify any failures in the OSH management of machinery and should be documented.

2.4.4.9. The results of such investigations should be communicated to the safety and health committee, where it exists, and the committee should make appropriate recommendations.

2.4.4.10. The results of investigations, in addition to any recommendations from the safety and health committee, should be communicated to appropriate persons for corrective action, included in the management review and considered for continual improvement activities.

Safety and health in the use of machinery

2.4.5. Recording and documentation

2.4.5.1. Employers should establish appropriate recording systems relating to safety and health in the use of machinery and document the relevant information on matters such as significant safety and health hazards and risks arising from machinery used in the workplace, the arrangements for prevention and control, and details of any dangerous occurrences or accidents that occur. Employers should ensure that such records are available and readily retrievable at all reasonable times for the workers concerned and their representatives and the competent authority. Employers should share information on faults and defects with the manufacturer and supplier.

2.4.5.2. Records and documentation on safety in the use of machinery should be periodically reviewed, updated and, where appropriate, communicated and made readily accessible to workers and their representatives and the competent authority.

2.4.5.3. Employers should consider creating documented work methods for machinery identified as high risk following the risk assessment. This could include, but should not be limited to:

- (a) safe operating procedures (SOPs);
- (b) job safety analysis (JSA);
- (c) safe work method statements (SWMSs);
- (d) work instruction (WI).

These can be used for training, competency assessment, quality and skill development purposes.

2.4.6. Use of machinery

2.4.6.1. Employers should take the measures necessary to ensure that machinery is suitable for the work to be carried out, or otherwise properly adapted for its intended purpose, and is safe for workers.

General obligations, responsibilities and duties

2.4.6.2. Employers should ensure that machinery is correctly installed and safeguarded and that protective devices and markings are used so that workers are protected from danger to their safety and health.

2.4.6.3. Employers should ensure that workers are adequately trained and competent.

2.4.6.4. Employers should ensure adequate and competent supervision of work and work practices, including adherence to work procedures.

2.4.7. Maintenance

2.4.7.1. Employers should take all necessary measures to ensure that, throughout its working life, machinery is maintained in a condition such that it continues to meet the relevant safety requirements. The manufacturer's instructions should be taken into account when maintenance is carried out.

2.4.7.2. Employers should ensure the safety of machinery through a system of preventive maintenance, including regular inspections and testing, where appropriate, of protective devices and guards and emergency stops. Any defects should be rectified promptly. In the event that serious defects are noted, the machinery should not be used until the defects have been corrected.

2.4.7.3. Where appropriate, the maintenance systems should include written procedures and communication on how the work can be carried out safely (for example, "permit to work" systems, procedures for working in confined spaces and lock-off procedures).

2.4.7.4. Employers should ensure that maintenance is performed safely and that, where appropriate:

- (a) the work is performed in accordance with the relevant special instructions and procedures;

Safety and health in the use of machinery

- (b) before the work begins, approval is given by the appointed supervisor; and
- (c) the necessary arrangements have been made at the workplace to ensure that the work being carried out will not endanger the maintenance workers or other persons.

2.4.7.5. Where there are specific hazards such as electricity, pressure differentials, poor air quality or radiation, employers should ensure that such hazards are identified and controlled so that workers and other persons in the workplace are not endangered. This should include confirmation that:

- (a) electrical, gas and liquid connections have been isolated and any excess pressure in the systems concerned has been discharged;
- (b) any unexpected movement of machinery is prevented;
- (c) suspended loads have been secured;
- (d) scaffolding, work platforms and ladders used for the work have an adequate stability and carrying capacity;
- (e) the tools to be used are in good condition and suitable for their intended purpose;
- (f) when tanks or confined spaces are serviced, or inspected or cleaned, measures have been taken to control the danger caused by lack of oxygen, toxic gases or other hazardous substances, and that appropriate emergency procedures are in place;
- (g) access to the danger area is restricted to essential personnel; and
- (h) appropriate PPE and protective clothing are used.

2.4.7.6. Emergency prevention, preparedness and response arrangements should be established and maintained in relation to the use of machinery. These arrangements should identify the potential for

General obligations, responsibilities and duties

accidents and emergency situations. They should be made according to the size and nature of activity of the organization.

2.4.7.7. Emergency prevention, preparedness and response arrangements should be established in cooperation with external emergency services and other bodies where applicable.

2.4.7.8. Where machinery has an inspection log, it should be kept up to date.

2.4.7.9. Employers should ensure that if maintenance is required while the machinery is running, it is performed by competent persons, and risk mitigation measures, such as use of “hold to run” controls with slow running speeds, are applied.

2.4.8. Decommissioning and disposal

2.4.8.1. Employers should ensure that the decommissioning and disposal of machinery are carried out safely, taking into account the manufacturer’s instructions and in accordance with national law and practice.

2.4.9. Competence, education and training of workers

2.4.9.1. Employers should ensure that workers have received the necessary training, information and instructions to perform the work competently and safely. Taking into account information provided by the manufacturer and supplier, the training, information and instructions should include information on:

- (a) risks which the use of the machinery may entail;
- (b) risk avoidance and foreseeable abnormal situations;
- (c) safe working procedures; and
- (d) the use of PPE.

Safety and health in the use of machinery

2.4.9.2. Workers should be instructed on how to obtain and use the information provided to prevent accidents.

2.4.9.3. In-house training programmes organized by employers should be developed in consultation with workers and their representatives. Training programmes should:

- (a) cover all workers at the workplace, including managers and supervisors, migrant and temporary workers and contractors, as appropriate;
- (b) be conducted by competent persons and provided during working hours;
- (c) include effective and timely initial and refresher training at appropriate intervals;
- (d) include participant evaluation for comprehension and retention of the matters taught; and
- (e) be reviewed periodically by the safety and health committee, where it exists, or by employers in consultation with workers and their representatives, modified as necessary, and adequately documented.

2.4.9.4. The employer should provide training required by national law and practice, as appropriate.

2.4.9.5. Training, instruction and information should be carried out in an appropriate manner using written, oral, visual and participative approaches in order to ensure that workers have understood the material, and should be given in a language understood by the workers.

2.4.9.6. The extent of the training and instruction received and required should be reviewed and updated simultaneously with the review of the working systems and practices.

General obligations, responsibilities and duties

2.4.9.7. The review should specifically include an examination of the following points:

- (a) whether workers understand the hazards and risks of the machinery they use;
- (b) whether workers understand the most effective use of the guarding and protection measures provided; and
- (c) whether workers are familiar with procedures in the event of an accident or emergency.

2.4.9.8. Employers should ensure that all workers present at the worksite are made aware of the potential dangers in the work area resulting from machinery.

2.4.10. Recording and notification of accidents and diseases to the competent authority

2.4.10.1. Employers should set up a system for the recording and notification of occupational accidents, occupational diseases and dangerous occurrences caused by machinery to the competent authority in accordance with national law and practice.

2.4.10.2. The notification report should contain relevant information on the nature, cause and consequences of the dangerous occurrences, occupational diseases or accidents in accordance with national legislation.

2.5. Worker participation

2.5.1. Workers' responsibilities

2.5.1.1. Workers should:

- (a) follow safe working methods as instructed by their employers;
- (b) cooperate with their employers in ensuring safety in the use of machinery;

Safety and health in the use of machinery

- (c) use and take care of PPE, protective clothing and any facilities made available to them, and not misuse anything provided for their own protection or the protection of others; and
- (d) participate actively in safety and health training.

2.5.1.2. Workers should take all reasonable steps to eliminate or minimize the risk to themselves and to others resulting from their use of machinery at work.

2.5.1.3. Workers should inform their supervisor without delay of any situation which they believe could present a risk.

2.5.2. Workers' rights

2.5.2.1. Workers using machinery should have the right to:

- (a) participate in the application and review of relevant OSH measures and, in accordance with national law and practice, to select OSH representatives; and
- (b) be consulted, informed and trained on all relevant aspects of machinery use, including emergency procedures associated with their work. Information should be presented in a form and language which workers easily understand.

2.5.2.2. Workers and their representatives should have the right to:

- (a) where appropriate, participate in accident investigations carried out by employers and the competent authority; and
- (b) be consulted before decisions are taken on issues relevant to safety in the use of machinery at the workplace and to be involved in risk assessment and the implementation and review of risk control measures and have the time and resources to do so.

General obligations, responsibilities and duties

2.5.2.3. Workers should have the right to remove themselves without suffering undue consequences from work situations which they have reasonable justification to believe present an imminent and serious danger to their safety or health resulting from machinery. They should inform their supervisor immediately of any machinery hazard. Workers who justifiably take those actions should be protected from victimization, for which there should be recourse in national laws and practice.

2.5.2.4. Workers should have the right to appeal to the competent authority if they consider that the measures taken and the means used by the employer are inadequate for the purpose of ensuring OSH at work in accordance with national law and practice.

2.6. Cooperation

2.6.1. The competent authority, designers, manufacturers and suppliers of machinery, and employers and workers and their representatives should cooperate in a constructive manner to ensure that the objectives of this code of practice are achieved.

2.6.2. Employers, in discharging their responsibilities, should cooperate as closely as possible with workers or their representatives with respect to safety in the use of machinery.

2.6.3. Workers should cooperate as closely as possible with their employers in the discharge by the latter of their responsibilities and should comply with all procedures and practices relating to safety in the use of machinery.

2.6.4. Where workers have removed themselves from danger in accordance with 2.5.2.3, employers, in cooperation with workers and their representatives, should immediately investigate the risk and take any corrective action necessary.

Safety and health in the use of machinery

2.6.5. The employer should establish and encourage the participation of workers and their representatives in a safety and health committee, and recognize workers' safety and health representatives, in accordance with national law and practice. Such safety and health committees should give due attention to safety and health in the use of machinery and the prevention of accidents and ill health due to machinery.

2.6.6. Employers should establish and maintain appropriate arrangements and procedures for:

- (a) ensuring internal communication between relevant levels and functions of the organization in the use of machinery; and
- (b) ensuring that the concerns, ideas and inputs of workers and their representatives are received, considered and responded to.

PART II. TECHNICAL REQUIREMENTS AND SPECIFIC MEASURES

The relevant sections of this part should be used by manufacturers and suppliers to ensure that machinery is designed and constructed in such a way that it is safe for use and fits the purpose for which it is intended. The relevant sections of this part should be used by employers to assess whether machinery they select and use or modify is fit for purpose and suitable for the specific working environment and conditions.

3. General statements on the working environment

3.1. Materials and products

3.1.1. Measures should be taken to ensure that materials used to construct machinery, and products used or created during its use, do not endanger safety or health of people. In particular, where fluids are used, the machinery should be designed and constructed so as to prevent risks from filling, use, recovery and draining.

3.2. Lighting

3.2.1. Adequate and suitable lighting should be provided for the operation of machinery so that machinery movements, controls and displays can easily be seen.

3.2.2. Machinery should be supplied with integral lighting suitable for the operations concerned where the absence of such lighting would be likely to cause a risk despite ambient lighting of normal intensity. Such lighting should not cause dangerous stroboscopic effects, dazzle or harmful shadow.

3.2.3. Localized lighting should be provided around the work area when the machinery or guards render normal lighting inadequate for safe operation. Localized lighting should also be provided in

Safety and health in the use of machinery

regular maintenance areas that are poorly lit, for example inside certain electrical compartments where electrical isolation is necessary for access.

3.2.4. Artificial lighting should not produce glare or disturbing shadows.

3.2.5. Internal parts requiring inspection and adjustment, as well as the maintenance areas, should be provided with appropriate lighting.

3.3. Design of machinery to facilitate its handling

3.3.1. Machinery and each component part thereof should:

- (a) be capable of being handled and transported safely; and
- (b) be designed and packaged so that it can be stored safely and protected from damage.

3.3.2. Machinery should be designed to ensure that during transportation of the machinery and its component parts there should be no possibility of sudden movements or hazards due to instability as long as the machinery and its component parts are handled in accordance with the relevant instructions.

3.3.3. Where the weight, size or shape of machinery or its various component parts prevent them from being moved by hand, the machinery or each component part should:

- (a) be fitted with attachments for lifting gear; or
- (b) be designed so that it can be fitted with such attachments; or
- (c) be shaped in such a way that standard lifting gear can easily be attached.

3.3.4. Where machinery, or any of its component parts, is to be moved by hand, it should be either:

General statements on the working environment

- (a) easily movable; or
- (b) equipped for picking up and moving safely.

3.3.5. Special arrangements should be made for the handling of tools and machinery parts such as sharp edges which, even if light-weight, may be hazardous.

3.4. Ergonomics

3.4.1. Considerations at the design and manufacturing stages

3.4.1.1. Designers and manufacturers should design and produce machinery with due regard to ergonomic principles.

3.4.1.2. Under the intended conditions of use, the discomfort, fatigue and physical and psychological stress faced by the operator should be reduced to the minimum possible, taking into account ergonomic principles such as:

- (a) allowing for the variability of the operator's physical dimensions, strength and stamina;
- (b) providing enough space for movements of the parts of the operator's body;
- (c) avoiding a machine-determined work rate;
- (d) avoiding monitoring that requires lengthy concentration; and
- (e) adapting the human-machine interface to the foreseeable characteristics of the operators.

3.4.1.3. In applying the ergonomic requirements for machinery used in the workplace, the ergonomic factors shown in figure 5 should be considered.

Figure 5. Ergonomic factors

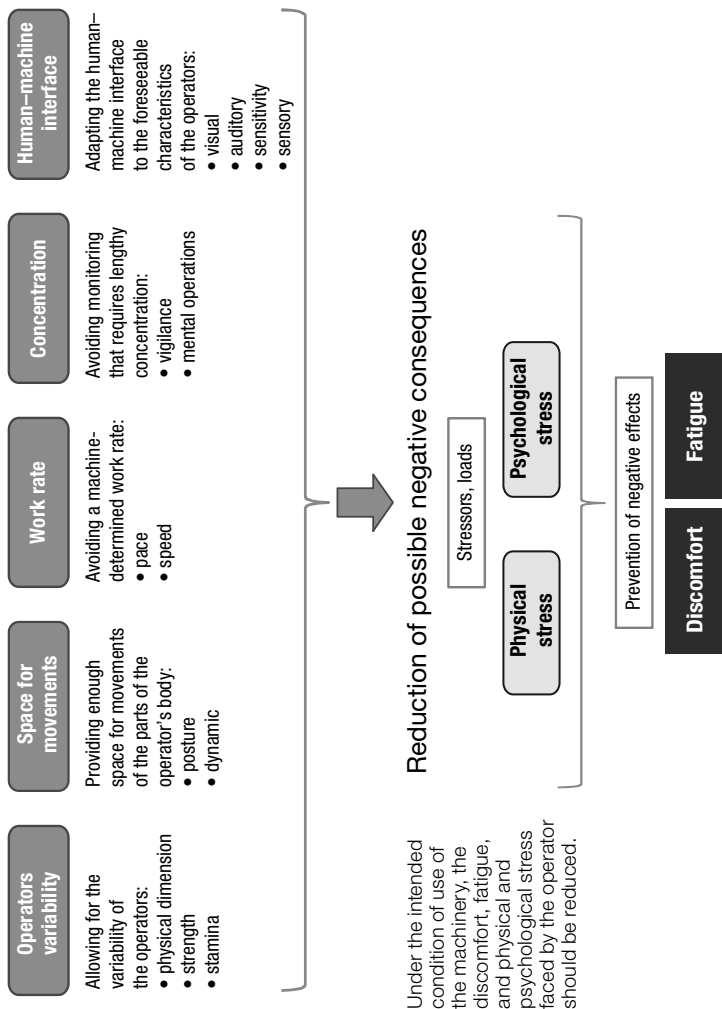

General statements on the working environment

Explanatory notes:

- (i) Work can be *static* or *dynamic*: in static work, the load is held in a stationary position ("static" means stationary or fixed); static exertions refer to physical exertions (such as gripping, holding a posture) in which the same position or posture is held throughout the exertion (also referred to as "static loading"). In dynamic work, both the load and the worker move. Work can be classed as sedentary, moderate or strenuous. Static work is far more demanding on the body and body structures than dynamic work.
- (ii) *Physical dimension*: for example, the height, reach and body stature or type. It is the measurement of human body characteristics such as size and shape (breadth, girth and distance between anatomical points). It also includes segment masses, the centres of gravity of body segments and the ranges of joint motion, which are used in biomechanical analyses of work postures.
- (iii) *Strength*: for example, the degree of musculoskeletal capability and the capacity to produce force or torque with voluntary muscle contraction. Maximum strength is defined as the capacity to produce force or torque with a maximum voluntary muscle contraction.
- (iv) *Stamina*: the mental and physical ability to concentrate and carry out the work.
- (v) *Posture*: the position the body takes or is required to take while undertaking work.
- (vi) *Dynamic factor*: the ability of the worker to move around the workstation and the biomechanical aspects of the human body in motion.
- (vii) *Pace*: controlling the worker's rate of work through external means.
- (viii) *Speed*: the speed of movement required to carry out the task.
- (ix) *Vigilance*: the ability to remain alert, including the ability to respond to sensory stimuli and alarms during the period of work.
- (x) *Mental operations*: the mental processing required for repetitive and complex mental operations throughout the performance of the task.
- (xi) *Visual factor*: display screens, dials, signs, symbols, etc.
- (xii) *Auditory factor*: alarms, sirens, warning bells, etc.
- (xiii) *Sensitivity*: the ability to detect or respond to slight changes, signals or influences.
- (xiv) *Sensory*: touch, vibration, heat, cold, etc.

Safety and health in the use of machinery

3.4.1.4. Adjustable features

3.4.1.4.1. Adjustability, for example of height, to accommodate users of different sizes should be taken into account in machinery design.

3.5. Operating positions

3.5.1. The operating position should be designed and constructed in such a way as to prevent any risk due to exhaust gases or lack of oxygen.

3.5.2. If the machinery is intended to be used in a hazardous environment presenting risks to the safety and health of the operator, or if the machinery itself gives rise to a hazardous environment, adequate means should be provided to ensure that the operator has good working conditions and is protected against any foreseeable hazards.

3.5.3. Where appropriate, the operating position should be fitted with an adequate cabin designed, constructed and equipped to fulfil the above requirements. The exit should allow rapid evacuation. Moreover, where applicable, an emergency exit should be provided in a direction which is different from the usual exit.

3.6. Seating

3.6.1. Where appropriate and where the working conditions permit, workstations constituting an integral part of the machinery should be designed to allow the installation of seats.

3.6.2. If the operators are supposed to sit during operation, and the operating position is an integral part of the machinery, the seat should be provided with the machinery.

General statements on the working environment

3.6.3. Operators' seats should enable them to maintain a stable position, and the operators should be able to adjust their seats and their distance from the control devices.

3.6.4. If the machinery is subject to vibration, the seat should be designed and constructed in such a way as to reduce the vibration transmitted to the operator to the lowest level that is reasonably possible. The seat mountings should withstand all stresses to which they can be subjected. Where there is no floor beneath the feet of the operator, footrests covered with a slip-resistant material should be provided.

4. Control systems

4.1. Safety and reliability of control systems

4.1.1. Control systems should be designed and constructed in such a way as to ensure that as few hazardous situations as possible arise. They should be designed and constructed taking into account the following aspects:

- (a) they should be able to withstand the intended operating stresses and external influences, taking into account foreseeable abnormal situations. External stresses include humidity, temperature, impurities, vibration and electric fields;
- (b) a fault in the hardware or software of the control system should not lead to hazardous situations;
- (c) errors in the control system logic should not give rise to hazardous situations; and
- (d) reasonably foreseeable human error during operation should not give rise to hazardous situations.

4.1.2. Particular attention should be paid to the following points:

- (a) the machinery should not start unexpectedly;
- (b) the parameters of the machinery should not change in an uncontrolled way;
- (c) the machinery should not be prevented from stopping if the stop command has already been given;
- (d) no moving part of the machinery or piece held by the machinery should fall or be ejected unintentionally;
- (e) automatic or manual stopping of the moving parts, whatever they may be, should be unimpeded;

- (f) protective devices should remain fully effective or give a stop command; and
- (g) safety-related parts of the control system should apply in a coherent way to the whole of an assembly of machinery and partly completed machinery.

4.1.3. For cableless control, an automatic stop should be activated when correct control signals are not received, including loss of communication.

4.2. Control devices

4.2.1. Control devices should be:

- (a) clearly visible and identifiable and readily distinguishable from one another by their separation, size, shape, colours or feel, and by labelling controls either with words or with unambiguous and easily recognizable symbols to identify the function or consequences of using the controls;
- (b) designed in such a way that controls for starting or stopping are clearly marked;
- (c) positioned in such a way as to be safely operated without hesitation or loss of time and without ambiguity;
- (d) designed in such a way that the movement of the control device is consistent with its effect;
- (e) located outside danger zones, except where necessary for certain control devices such as an emergency stop or a teach pendant;
- (f) positioned in such a way that their operation cannot cause additional risk;
- (g) designed or protected in such a way that the desired effect, where a hazard is involved, can be achieved only by a deliberate action; and

Safety and health in the use of machinery

(h) made in such a way as to withstand any foreseeable forces; particular attention should be paid to emergency stop devices likely to be subjected to considerable forces.

4.2.2. Where a control device is designed and constructed to perform several different actions, that is, where there is no one-to-one correspondence, the action to be performed should be clearly displayed and subject to confirmation where necessary.

4.2.3. Control devices should be so arranged that their layout, travel and resistance to operation are compatible with the action to be performed, taking account of ergonomic principles.

4.2.4. Machinery should be fitted with such visual, auditory or tactile indicators as may be required for safe operation. The operator should be able to perceive them from the control position.

4.2.5. From each control position, the operator should be able to ensure that nobody is in a danger zone, or alternatively the control system should be designed and constructed in such a way that starting is prevented while someone is in a danger zone. If neither of these solutions is practicable, an acoustic and visual warning signal should be given before the machinery starts. Any persons exposed should have time to leave the danger zone or prevent the machinery from starting up.

4.2.6. If necessary, it should be ensured that the machinery can be controlled only from control positions located in one or more predetermined zones or locations.

4.2.7. Where there is more than one control position, the control system should be designed in such a way that the use of one of them precludes the use of the others, except for stop controls and emergency stops.

4.2.8. When machinery has two or more operating positions, each position should be provided with all the required control devices

without the operators hindering or placing each other in a hazardous situation.

4.3. Starting

4.3.1. Machinery should be fitted with a specific start control device. It should be possible to start machinery only by voluntary activation of the control device provided for that purpose. Start controls should be shrouded or otherwise protected to prevent inadvertent operation. Near each start control there should be a stop control.

4.3.2. The same requirement applies:

- (a) when restarting the machinery after a stoppage, whatever the cause; and
- (b) when effecting a significant change in the operating conditions.

4.3.3. However, if there is a voluntary activation of a device that restarts the machinery or changes the operating conditions other than the control device provided for the purpose, this may only be used on condition that it does not lead to a hazardous situation – for example, initiation of certain functions of machinery by the closure of an interlocking guard.

4.3.4. For machinery functioning in automatic mode, the starting of the machinery, restarting after a stoppage, or a change in operating conditions, may be possible without intervention, provided this does not lead to a hazardous situation.

4.3.5. Where machinery has several starting control devices and operators can therefore place one another in danger, additional devices should be fitted to preclude such risks. If safety requires that starting and stopping should be performed in a specific sequence, there should be devices which ensure that these operations are performed in the correct order.

Safety and health in the use of machinery

4.4. Stopping

4.4.1. Normal stop

4.4.1.1. Machinery should be fitted with a reliable control device allowing the machinery to be brought safely to a complete stop.

4.4.1.2. Each workstation should be fitted with a control device to stop some or all of the functions of the machinery, depending on the existing hazards, so that the machinery is rendered safe.

4.4.1.3. The machinery's stop control should have priority over the start controls.

4.4.1.4. Once the machinery or its hazardous functions have stopped, the energy supply to the actuators concerned should be cut off.

4.4.2. Operational stop

4.4.2.1. Where, for operational reasons, a stop control that does not cut off the energy supply to the actuators is required, the stop condition should be monitored and maintained.

4.4.3. Emergency stop

4.4.3.1 Emergency stop controls should be:

- (i) coloured red; and
- (ii) positioned in such a way as to be safely operated without hesitation or loss of time and without ambiguity.

4.4.3.2. Machinery should be fitted with one or more emergency stop devices to enable actual or impending danger to be averted. They should be located where any operator can easily reach them.

4.4.3.3. The following exceptions apply:

- (a) machinery in which an emergency stop device would not lessen the risk, either because it would not reduce the stopping time or because it would not enable the special measures required to deal with the risk to be taken; and
- (b) portable hand-held and hand-guided machinery.

4.4.3.4. The emergency stop devices should:

- (a) be clearly identifiable, clearly visible and quickly accessible, so that they can be used to stop the hazardous process as quickly as possible, without creating additional risks; and
- (b) where necessary, trigger or permit the triggering of certain safeguard movements.

4.4.3.5. Once active operation of the emergency stop device has ceased following a stop command, that command should be sustained by engagement of the emergency stop device until that engagement is specifically overridden; it should not be possible to engage the device without triggering a stop command; it should be possible to disengage the device only by an appropriate operation, and disengaging the device should not restart the machinery but only permit restarting.

4.4.3.6. The emergency stop function should be available and operational at all times, regardless of the operating mode.

4.4.3.7. Emergency stop devices should be a back-up provided in addition to other safeguarding measures, not as a substitute for them.

4.4.4. Assembly of machinery

4.4.4.1. In the case of machinery or parts of machinery designed to work together, the machinery should be designed and constructed in such a way that the stop controls, including the emergency stop devices, can stop not only the machinery itself but also all related equipment, if its continued operation may be dangerous.

Safety and health in the use of machinery

4.4.5. Selection of control or operating modes

4.4.5.1. The control or operating mode selected should override all other control or operating modes, with the exception of the emergency stop.

4.4.5.2. If machinery has been designed and constructed to allow its use in several control or operating modes requiring different protective measures and work procedures, it should be fitted with a mode selector which can be locked in each position. Each position of the selector should be clearly identifiable and should correspond to a single operating or control mode.

4.4.5.3. The selector may be replaced by another selection method which restricts the use of certain functions of the machinery to certain categories of operators.

4.4.5.4. If, for certain operations, the machinery should be able to operate with a guard displaced or removed or a protective device disabled, the control or operating mode selector should simultaneously:

- (a) disable all other control or operating modes;
- (b) permit the operation of hazardous functions only by control devices requiring sustained action;
- (c) permit the operation of hazardous functions only in reduced risk conditions while preventing hazards from linked sequences; and
- (d) prevent any operation of hazardous functions by voluntary or involuntary action on the sensors of the machinery.

If these four conditions cannot be fulfilled simultaneously, the control or operating mode selector should activate other protective measures designed and constructed to ensure a safe intervention zone.

4.4.5.5. In addition, the operator should be able to control operation of the parts which are being worked on from the adjustment point.

4.5. Failure of the energy source

4.5.1. The fluctuation, interruption and re-establishment after an interruption of the energy source to the machinery should not lead to a dangerous situation (e.g. fails-to-safe).

4.5.2. Particular attention should be given to the following points:

- (a) the machinery should not start unexpectedly;
- (b) the parameters of the machinery should not change in an uncontrolled way when such change can lead to hazardous situations;
- (c) the machinery should not be prevented from stopping if the command has already been given;
- (d) no moving part of the machinery, or piece held by the machinery, should fall or be ejected unintentionally;
- (e) automatic or manual stopping of the moving parts, whatever they may be, should be unimpeded; and
- (f) the protective devices should remain fully effective or give a stop command.

5. Machinery guarding and protection against mechanical hazards

5.1. Risk of loss of stability

5.1.1. Machinery and its components and fittings should be stable enough to avoid overturning, falling or uncontrolled movements during use, transportation, assembly and dismantling.

5.1.2. If the shape of the machinery itself or its intended installation does not offer sufficient stability, appropriate means of anchorage should be incorporated and indicated in the instructions.

5.2. Risk of break-up during operation

5.2.1. The various parts of machinery and their linkages should be able to withstand the stresses to which they are subject when used.

5.2.2. The durability of the materials used should be adequate for the nature of the working environment foreseen by the manufacturer, in particular as regards the phenomena of fatigue, ageing, corrosion and abrasion, and the maintenance schedule of the owner.

5.2.3. The instructions should indicate the type and frequency of inspections and maintenance required for safety reasons. They should, where appropriate, indicate the parts subject to wear and the criteria for replacement.

5.2.4. Where a risk of rupture or disintegration remains despite the measures taken, the parts concerned should be mounted, positioned and guarded in such a way that any fragments will be contained, preventing hazardous situations.

5.2.5. Rigid or flexible pipes carrying fluids, particularly those under high pressure, should be able to withstand foreseeable internal

Machinery guarding and protection against mechanical hazards

and external stresses and should be firmly attached and protected to ensure that no risk is posed by a rupture.

5.2.6. Where the material to be processed is fed to the tool automatically, the following conditions should be met so as to prevent risks to persons:

- (a) when the work piece comes into contact with the tool, the latter should have attained its normal working condition; and
- (b) when the tool starts and stops (intentionally or accidentally), the feed movement and the tool movement should be coordinated.

5.3. Risks due to falling or ejected objects

5.3.1. Measures should be taken to prevent risks arising from falling or ejected objects.

5.4. Risks due to surfaces, edges or angles

5.4.1. In so far as their purpose allows, parts that are accessible during use and maintenance of the machinery should have no sharp edges, sharp angles or rough surfaces likely to cause injury.

5.5. Risks related to combined machinery

5.5.1. Where the machinery is intended to carry out several different operations with manual removal of the piece between each operation (combined machinery), it should be designed and constructed in such a way as to enable each element to be used separately, without the other elements constituting a risk to exposed persons.

5.6. Risks related to variations in operating conditions

5.6.1. Where the machinery performs operations under different conditions of use, it should be designed and constructed in such a way

Safety and health in the use of machinery

that selection and adjustment of these conditions can be carried out safely and reliably.

5.7. Risks related to moving parts

5.7.1. Prevention of hazards due to moving parts of machinery should take into account:

- (a) the movement of machinery parts consisting basically of rotary, sliding or reciprocating motion, or a combination of these, such as the movements of spindles, chucks, fan blades, counter-rotating gear wheels or rollers, and stroking blades; and
- (b) the movement of machinery parts which may have the potential to cause injury, for example by entanglement, friction or abrasion, cutting, shearing, stabbing or puncture, impact, crushing, or drawing a person into a position where injury can occur.

5.7.2. Moving parts of machinery should be designed and constructed in such a way as to prevent risks of contact which could lead to accidents and should, where risks persist, be fitted with guards or protective devices.

5.7.3. All necessary steps should be taken to prevent accidental blockage of moving parts involved in the work. If a blockage remains possible despite the precautions taken, the necessary specific protective devices and tools should be provided to enable the equipment to be unblocked safely. The instructions and, where possible, a sign on the machinery should identify these specific protective devices and how they are to be used.

5.8. Choice of protection against risks arising from moving parts

5.8.1. Guards or protective devices designed to protect against risks arising from moving parts should be selected on the basis of the

Machinery guarding and protection against mechanical hazards

type of risk. The following guidelines in 5.9 to 5.15 should be used to help to make this choice.

5.9. Moving transmission parts

5.9.1. Guards designed to protect persons against the hazards generated by moving transmission parts should be either:

- (a) fixed guards; or
- (b) interlocking movable guards.

5.9.2. Interlocking movable guards should be used where frequent access is envisaged.

5.10. Moving parts involved in the process

5.10.1. When a process requires access to a danger zone and a fixed guard is impracticable, an interlocking guard should be considered. Guards or protective devices designed to protect persons against the hazards generated by moving parts involved in the process should be:

- (a) fixed guards;
- (b) interlocking movable guards;
- (c) protective devices; or
- (d) a combination of the above.

5.10.2. However, when certain moving parts directly involved in the process cannot be made completely inaccessible during operation because of the need for operator intervention, such parts should be fitted with:

- (a) fixed guards or interlocking movable guards preventing access to parts to which access is not necessary for the purpose of the work which has to be performed; and

Safety and health in the use of machinery

- (b) adjustable guards restricting access to those sections of the moving parts to which access is necessary.

5.11. Risks of uncontrolled movements

5.11.1. When a part of the machinery has been stopped, any drifting away from the stopping position for whatever reason other than action on the control devices should be prevented or should not present a hazard.

5.12. General requirements for guards

5.12.1. Guards and protective devices should protect against danger, including risks from moving parts. They should:

- (a) be of robust construction;
- (b) be securely held in place;
- (c) not give rise to any additional hazard;
- (d) not be easy to bypass or render non-operational, or be easily defeated;
- (e) be located at an adequate distance from the danger zone;
- (f) cause minimum obstruction of the view of the production process; and
- (g) enable essential work to be carried out on the installation and replacement of tools and for maintenance purposes by restricting access exclusively to the area where the work has to be done, if possible without the guard having to be removed or the protective device having to be disabled.

5.12.2. In addition, guards should protect against the ejection or falling of materials or objects and against emissions generated by the machinery.

Machinery guarding and protection against mechanical hazards

5.13. Special requirements for guards

5.13.1. Fixed guards

5.13.1.1. Fixed guards should be used whenever practicable. They should be designed so as to prevent access to the dangerous parts of the machinery.

5.13.1.2. Fixed guards should be fixed by systems that can be opened or removed only with tools.

5.13.1.3. Their fixing (attachment) systems should remain attached to the guards or to the machinery when the guards are removed.

5.13.1.4. Where possible, guards should be incapable of remaining in place without their fixings (attachments).

5.13.2. Interlocking movable guards

5.13.2.1. Interlocking movable guards should, as far as possible, remain attached to the machinery when open.

5.13.2.2. Interlocking movable guards should be associated with an interlocking device which:

- (a) prevents the start of hazardous machinery functions until the guards are closed; and
- (b) gives a stop command whenever the guards are opened.

5.13.2.3. Where it is possible for an operator to reach the danger zone before the risk due to the hazardous machinery functions has ceased, movable guards should be associated with a guard-locking device in addition to an interlocking device which:

- (a) prevents the start of hazardous machinery functions until the guard is closed and locked; and

Safety and health in the use of machinery

- (b) keeps the guard closed and locked until the risk of injury from the hazardous machinery functions has ceased.

5.13.2.4. Interlocking movable guards should be designed in such a way that the absence or failure of one of their components prevents starting, or stops the hazardous machinery functions.

5.14. Adjustable guards restricting access

5.14.1. Adjustable guards restricting access to those areas of the moving parts strictly necessary for the work should be:

- (a) adjustable manually or automatically, depending on the type of work involved; and
- (b) readily adjustable without the use of tools.

5.15. Special requirements for protective devices

5.15.1. Protective devices should be designed and incorporated into the control system in such a way that:

- (a) moving parts cannot start up while they are within the operator's reach;
- (b) persons cannot reach moving parts while those parts are moving; and
- (c) the absence or failure of one of their components prevents starting or stops the moving parts.

5.15.2. Protective devices should be adjustable only by means of an intentional action.

6. Machinery guarding and protection against other hazards

6.1. Electricity supply

6.1.1. Where machinery has an electricity supply, it should be designed, constructed and equipped in such a way that all hazards of an electrical nature are or can be prevented, in accordance with national law and practice.

6.2. Static electricity

6.2.1. Machinery should be designed and constructed to prevent or limit the build-up of potentially dangerous electrostatic charges and be fitted with a discharging system.

6.3. Energy supply other than electricity

6.3.1. Where machinery is powered by sources of energy other than electricity, it should be so designed, constructed and equipped as to prevent all potential risks associated with such sources of energy.

6.4. Errors in fitting

6.4.1. Errors likely to be made when fitting or refitting certain parts which could be a source of risk should be precluded by the design and construction of the parts or, failing this, information explaining how to fit them correctly should be provided on the parts themselves and their housings. The same information should be provided on moving parts and their housings where the direction of movement needs to be known in order to prevent a risk.

6.4.2. Where necessary, the instructions for use should give further information on these risks.

Safety and health in the use of machinery

6.4.3. Where a faulty connection can be a source of risk, the design should make it impossible to connect parts incorrectly; failing this, information should be provided on the items to be connected and, where appropriate, on the means of connection.

6.5. Extreme temperatures

6.5.1. Steps should be taken to eliminate any risk of injury arising from contact with, or proximity to, machinery parts or materials at very high or very low temperatures.

6.5.2. The necessary steps should also be taken to avoid or protect against the risk of very hot or very cold material being ejected.

6.6. Effect of climate

6.6.1. When machinery is used in very high ambient temperatures and/or humidity (such as in tropical or subtropical regions) or in very low ambient temperatures, consideration in the design of machinery should be given to the following aspects:

- (a) the effect of extreme heat, cold and humidity on machinery;
- (b) the acceptability of PPE and the effect of climate on the protection provided by such equipment;
- (c) the effect of high and low ambient temperatures on workers in terms of fatigue;
- (d) the effect of high levels of sunlight;
- (e) heat stress problems in non-acclimatized personnel, particularly when the use of PPE is necessary;
- (f) the effect of climate on the stability of chemical substances used for operating machinery; and
- (g) the effect of climate on equipment operation and maintenance.

Machinery guarding and protection against other hazards

6.6.2. Occupational exposure limits originally developed and established in temperate climates should be applied with extreme caution in tropical areas because of the different ambient climatic conditions.

6.7. Fire

6.7.1. Machinery should be designed and constructed in such a way as to prevent any risk of fire or overheating posed by the machinery itself or by gases, liquids, dust, vapours or other substances produced or used by the machinery.

6.8. Explosion

6.8.1. Machinery should be designed and constructed in such a way as to prevent any risk of explosion posed by the machinery itself or by gases, liquids, dust, vapours or other substances produced or used by the machinery.

6.8.2. Where machinery is intended for use in a potentially explosive atmosphere, it should be designed and manufactured to exclude or minimize ignition sources and comply with any national laws and standards applicable to explosive atmospheres.

6.9. Noise

6.9.1. Machinery should be designed and constructed in such a way that risks resulting from the emission of airborne noise are eliminated or reduced to the lowest possible level, taking account of technical progress and the availability of means of reducing noise, in particular at source.

6.9.2. Where applicable, information should be supplied with the machinery on noise emissions, as required by national laws and standards, and on any additional safety precautions required. If this advice

Safety and health in the use of machinery

is incomplete, the employer should seek further information from the supplier, and if necessary arrange for competent persons to undertake measurements in accordance with nationally and internationally recognized standards.

6.9.3. The level of noise to which workers are exposed should not exceed the limits established by the competent authority or under internationally recognized standards. Noise measurements should be used to quantify the level of exposure of workers and compared to nationally or internationally agreed exposure limits.

6.9.4. As regards noise reduction, employers should give consideration to the following, normally referred to as a hearing conservation programme:

- (a) the appropriate choice of machinery which emits the least amount of noise, taking account of the work to be done;
- (b) noise reduction by technical means:
 - (i) reducing airborne noise, for example with shields, enclosures or soundabsorbent coverings;
 - (ii) reducing structure-borne noise, for example with damping or isolation;
- (c) alternative working methods that require less exposure to noise;
- (d) the design and layout of workplaces and workstations;
- (e) organization of work to reduce noise:
 - (i) limitation of duration and intensity of exposure; and
 - (ii) appropriate work schedules with adequate rest periods;
- (f) appropriate maintenance programmes for machinery, the workplace and workplace systems;

Machinery guarding and protection against other hazards

- (g) adequate information and training to instruct workers in the use and maintenance of machinery to minimize noise emission. Workers who may be exposed to noise levels above agreed levels should receive regular audiometric testing, in accordance with national laws and practice, and employers should ensure that workers in noisy environments are informed of the results of the testing.

6.9.5. If the risks arising from worker exposure to noise cannot be prevented by other means such as elimination or engineering control, appropriate, properly fitting personal hearing protectors should be made available for workers to use at no cost. The provision and use of hearing protection may be mandatory in conditions specified by national laws and standards.

6.10. Vibration

6.10.1. Machinery should be designed and constructed in such a way that risks resulting from whole-body and hand-transmitted vibration produced by the machinery are reduced to the lowest possible level, taking account of technical progress and the availability of means of reducing vibration, in particular at source.

6.10.2. The level of vibration and duration of exposure should not exceed the limits established by national laws and standards or internationally recognized standards. Vibration measurements should be used to quantify the level of exposures of workers and compared to nationally or internationally agreed exposure limits.

6.10.3. The manufacturer of the machinery should provide information in the relevant instruction handbook concerning vibration transmitted by the machinery to the operator's hands, arms or whole body; the instructions should include information relating to the aspects of installation, assembly and use that can reduce exposure to vibration.

Safety and health in the use of machinery

6.10.4. On the basis of the risk assessment, employers should establish and implement a programme of technical and organizational measures intended to minimize exposure to mechanical vibration and its associated potential risks, taking into account in particular:

- (a) alternative working methods that require less exposure to mechanical vibration;
- (b) the choice of machinery with an appropriate ergonomic design that takes into account the kind of work to be done and produces the least possible vibration;
- (c) the provision of auxiliary equipment that reduces the risk of injuries caused by vibration, such as seats that effectively reduce whole body vibration and handles which reduce the vibration transmitted to the hand–arm system;
- (d) appropriate maintenance programmes for the machinery, the workplace and workplace systems;
- (e) the design and layout of workplaces and workstations;
- (f) adequate information and training to instruct workers in the correct and safe use of machinery in order to minimize their exposure to mechanical vibration;
- (g) measures to limit the duration and intensity of exposure;
- (h) appropriate work schedules with adequate rest periods; and
- (i) the provision of clothing to protect exposed workers from cold and damp, which can exacerbate the effect of vibration.

6.11. Ionizing and non-ionizing radiation arising from the machinery

6.11.1. Radiation emissions that are not essential to the functioning of the machinery should be eliminated, or reduced to levels that

Machinery guarding and protection against other hazards

do not have adverse effects on workers as determined by a competent person, in accordance with national law and standards.

6.11.2. Any functional ionizing radiation emissions should be limited to the lowest level sufficient for the proper functioning of the machinery during maintenance and use. Where a risk exists, the necessary protective measures should be taken.

6.11.3. Any functional non-ionizing radiation emissions during maintenance and use should be limited to levels that do not have adverse effects on workers.

6.11.4. Machinery should be designed and constructed in such a way as to prevent any accidental emission of radiation.

6.11.5. The level of exposure of workers to ionizing radiation should be assessed, and the health of the workers should be monitored, in accordance with national law and practice.

6.11.6. When appropriate, the level of exposure of workers to non-ionizing radiation and its impact on their health should be assessed in accordance with national law and practice.

6.12. External radiation

6.12.1. Machinery should be designed and constructed in such a way that external radiation does not interfere with its operation.

6.13. Laser radiation

6.13.1. Where laser equipment is used, the following should be taken into account:

- (a) laser equipment fitted on machinery should be designed and constructed in such a way as to prevent any accidental emission of radiation;

Safety and health in the use of machinery

- (b) laser equipment fitted on machinery should be protected in such a way that effective radiation, radiation produced by reflection or diffusion, and secondary radiation do not damage health; and
- (c) optical equipment for the observation or adjustment of laser equipment fitted on machinery should be designed and fitted so as to prevent any health risk arising from the laser radiation.

6.14. Emissions of hazardous materials and substances

6.14.1. Machinery should be designed and constructed in such a way as to prevent any risks of inhalation, ingestion or contact with hazardous materials and substances (including penetration of such materials and substances through skin, eyes or mucous membranes) which it produces.

6.14.2. Where a hazard cannot be eliminated, the machinery should be so equipped that hazardous materials and substances can be contained, evacuated, ventilated, precipitated by water spraying, filtered, or treated by some other equally effective method.

6.14.3. Where the process is not completely enclosed during normal operation of the machinery, containment, ventilation and evacuation devices should be designed, maintained and positioned in such a way as to have the maximum effect.

6.14.4. Where the hazardous material has been collected and contained, the workers exposed should be protected from its hazardous effects.

6.15. Risk of being trapped in machinery

6.15.1. Machinery should be designed, constructed or fitted with a means of preventing a worker from being enclosed within it or, if that is not possible, with a means of summoning help.

Machinery guarding and protection against other hazards

6.16. Risk of slipping, tripping or falling

6.16.1. Parts of machinery on which workers are likely to move about or stand should be designed and constructed in such a way as to prevent workers from slipping, tripping or falling on or off these parts.

6.16.2. Where appropriate, such parts should be fitted with handholds that are fixed close to the operator to enable him or her to maintain stability.

6.16.3 Where fall PPE is used for maintenance, it should be appropriate for the purpose and anchor points should be provided in accordance with national law and practice.

6.17. Lightning

6.17.1. Machinery in need of protection against the effects of lightning when in use should be fitted with a system for conducting the electrical charge to earth.

6.18. Access to operating positions and servicing points

6.18.1. Machinery should be designed and constructed in such a way as to allow safe access to all areas where intervention is necessary during operation, adjustment and maintenance.

6.19. Isolation of energy sources

6.19.1. Machinery should be fitted with a means to disconnect and isolate it from all energy sources. Such isolators should be clearly identified. They should be capable of being locked in the off position if reconnection could endanger workers. Isolators should also be capable of being locked in the off position if an operator is unable to check that the energy is still cut off because of inaccessibility of areas that require checking or because workers are unable to view them from a different

Safety and health in the use of machinery

part of the access area. The employer should identify and implement specific procedures for the control of hazardous energy. These procedures should include preparation for shut-down, lock-out or tag-out, a permit-to-work system, and verification of isolation, as part of a formal management system.

6.19.2. After the energy is cut off, it should be possible to dissipate normally any energy remaining or stored in the circuits of the machinery without risk to workers.

6.19.3. As an exception to the requirement laid down in 6.19.1, certain circuits may remain connected to their energy sources in order, for example, to hold parts, to protect information, and to light interiors. In this case, special steps should be taken to ensure worker safety.

6.20. Worker intervention

6.20.1. Machinery should be designed, constructed and equipped in such a way that the need for worker intervention is limited. If worker intervention cannot be avoided, it should be possible to carry it out easily and safely.

6.21. Cleaning of internal parts

6.21.1. Machinery should be designed and constructed in such a way that it is possible to clean internal parts which have contained hazardous substances or preparations without entering them; any necessary unblocking should also be possible from the outside. If it is impossible to avoid entering the machinery, it should be designed and constructed in such a way as to allow cleaning to take place safely.

7. Information and marking

7.1. Information and information devices

7.1.1. The information needed to control machinery should be provided in a form that is unambiguous and easily understood. It should not be excessive to the extent of overloading the worker.

7.1.2. Visual display units or any other interactive means of communication between worker and machinery should be easily understood and easy to use.

7.2. Warning devices

7.2.1. Where the safety and health of workers may be endangered by a fault in the operation of unsupervised machinery, the machinery should be equipped in such a way as to emit an appropriate acoustic or visual signal as a warning.

7.2.2. Where machinery is equipped with warning devices, these should be unambiguous and easily perceived. The worker should have facilities to check the operation of such warning devices at all times.

7.2.3. The requirements of the specific national or international standards concerning colours and safety and health signals should be complied with.

7.3. Warning of residual risks

7.3.1. Where residual risks remain, the necessary warnings, including warning devices, should be provided.

Safety and health in the use of machinery

7.4. Marking of machinery

7.4.1. All machinery should be marked visibly, legibly and indelibly with the following minimum particulars:

- (a) the business name and full address of the manufacturer;
- (b) designation of the machinery;
- (c) designation of series or type;
- (d) serial number, if any; and
- (e) the year of construction, that is the year in which the manufacturing process is completed.

7.4.2. Machinery designed and constructed for use in a potentially explosive atmosphere should be marked accordingly.

7.4.3. Machinery should also bear full information relevant to its type and essential for safe use, such as the maximum permissible speed of certain rotating parts, the maximum diameter of tools to be fitted, and weight.

7.4.4. Where a machinery part needs to be handled during use and transportation with lifting equipment, its weight should be indicated legibly, indelibly and unambiguously.

7.4.5. Signs and pictograms should only be used if they are understood in the culture in which the machinery is to be used.

8. Supplementary measures relating to specific machinery types

8.1. Portable hand-held and hand-guided machinery (such as chainsaws, hedge trimmers, cartridge-operated tools, grinders, etc.)

8.1.1. Depending on the type of machinery, the machinery should have a supporting surface of sufficient size and a sufficient number of handles and supports of an appropriate size, arranged in such a way as to ensure the stability of the machinery under the intended operating conditions.

8.1.2. Except where technically impossible, or where there is an independent control device, in the case of handles which cannot be released in complete safety, the machinery should be fitted with manual start and stop control devices arranged in such a way that the operator can operate them without releasing the handles.

8.1.3. There should be no risk of accidental starting and continued operation after the operator has released the handles. Other equivalent steps should be taken if this requirement is not technically feasible.

8.1.4. The machinery should, where necessary, permit visual observation of the danger zone and of the interaction of the tool with the material being processed.

8.1.5. The machinery should have the handles designed and constructed to make starting and stopping simple.

8.1.6. In the case of chainsaws, refer to paragraph 387 of the ILO code of practice on safety and health in forestry work.

Safety and health in the use of machinery

8.2. Portable impact fixing machinery (pneumatic and explosive cartridge activated)

8.2.1. Energy should be transmitted to the impacted element by an intermediary component that does not leave the device.

8.2.2. An enabling device should prevent impact unless the machinery is positioned correctly with adequate pressure on the base material.

8.2.3. Involuntary triggering should be prevented; where necessary, an appropriate sequence of actions on the enabling device and the control device should be required to trigger an impact.

8.2.4. Accidental triggering should be prevented during handling or in case of shock.

8.2.5. It should be possible for loading and unloading operations to be carried out easily and safely.

8.2.6. Appropriate guard(s) should be provided by the manufacturer of the machinery and, where necessary, it should be possible to fit the device with splinter guard(s).

8.2.7. In the case of pneumatic tools, see section 7.3, and in the case of cartridge-operated tools, section 7.4, of the ILO code of practice on safety and health in construction.

8.3. Machinery for working wood and material with similar physical characteristics (such as circular saws, band saws, planing and thicknessing machinery)

8.3.1. All cutters and saw blades should, as far as possible, be enclosed.

8.3.2. Machinery should, wherever possible, be equipped with mechanical feeding devices.

Supplementary measures relating to specific machinery types

8.3.3. Machinery should be designed, constructed or equipped in such a way that the piece being machined can be placed and guided in safely; where the piece is hand-held on a workbench, the latter should be sufficiently stable during the work and should not impede the movement of the piece. Push sticks are an additional device used to keep hands away from the blade.

8.3.4. Where the machinery is likely to be used in conditions involving the risk of ejection of work pieces or parts thereof, it should be designed, constructed or equipped in such a way as to prevent such ejection or, if this is not possible, in such a way that ejection does not pose a risk to the workers.

8.3.5. The machinery should be equipped with an automatic brake that stops the tool in a sufficiently short time if there is a risk of contact with the tool while it slows down.

8.3.6. Where the tool is incorporated into machinery that is not fully automated, the latter should be designed and constructed in such a way as to eliminate or reduce the risk of injury.

8.4. Machinery presenting hazards due to its mobility (such as vehicles, earth-moving machinery, excavators, harvesters and tractors) (see Appendix II, Section 1, for detailed technical information)

8.4.1. The machinery should be suitable for its intended use and environment.

8.4.2. Drivers should be trained and competent in the use and operation of the machinery, including how to deal with visual obstructions, i.e. blind areas, in accordance with national law and practice.

8.4.3. Mobile machinery should, as far as possible, be segregated from workers on foot, and appropriate warnings and safe access routes should be provided.

Safety and health in the use of machinery

8.4.4. Drivers should be given adequate visibility of the machinery and its vicinity and, where appropriate, provided with clear acoustic and visual warnings of movement.

8.4.5. Machinery should be equipped with adequate parking and service brakes and systems for safe steering, including in the event of power failure.

8.4.6. Seats should be provided for all drivers and passengers, except for certain “stand-on” machinery such as small excavators and forklift trucks.

8.4.7. Driver and all passenger/maintenance locations should have safe access provision, and be protected from risks due to moving parts, weather, noise, dust, falling objects and machine roll-over, for example through the use of cabs which, where necessary, should have climate control, roll-over protective structures (ROPS), falling object protective structures (FOPS) and seatbelts, in accordance with national law and practice.

8.4.8. Controls should be designed so as to adequately reduce the risks due to inadvertent operation, including operation by non-authorized personnel, using, for example, locks, interlocks with seat switch, ergonomic shape and position, and logical and easily understood markings; where remote control is used, there should be monitoring of the link.

8.4.9. Fire protection and suppression systems, where required, should be provided with the machinery.

8.5. Lifting machinery (such as cranes and hoists)

(see Appendix II, Section 2, for detailed technical information)

8.5.1. Machinery should be suitable for the intended lifting operation (with regard to load, reach, environment and ground conditions).

Supplementary measures relating to specific machinery types

8.5.2. Non-routine lifting operations should be specially planned taking into account the need for effective communications and possible interaction with other work taking place.

8.5.3. Access to dangerous areas, such as areas underneath suspended loads, should be prevented.

8.5.4. Operators and slingers/riggers should be trained and competent in both the use of the machinery and the planned lifting operation in accordance with national law and practice.

8.5.5. All lifting machinery and accessories should be tested and provided with a certificate showing their safe working load and should be marked with their safe working load or have a safe load indicator, as appropriate, in accordance with national law and practice.

8.5.6. All lifting machinery and accessories should be maintained, inspected and tested at appropriate intervals by competent staff, in accordance with national law and practice. Any repairs to load carrying elements or control systems should be carried out only by competent persons and in keeping with the manufacturer's instructions, in accordance with national law and practice.

8.5.7. Means should be provided to ensure correct deployment of safety devices, such as interlocks on outriggers/stabilizers and landing doors on lifts and hoists.

8.5.8. Loads should be stable and secure and loss of power should not result in dangerous movement of lifting components or loss of the load.

8.5.9. The machinery should be designed to be stable in use and to prevent dangerous operation, for example through the use of load control equipment or overload warnings.

Safety and health in the use of machinery

8.5.10. Where national law and practice require it, cranes working in the vicinity of overhead power lines and other structures should be fitted with proximity devices.

8.6. Machinery for the lifting of persons (see Appendix II, Section 3, for detailed technical information)

8.6.1. Only machinery designed for the lifting of persons should be used for that purpose, and the machinery should have two independent safety systems to control the load. For exceptional use of other lifting equipment, see Appendix II.

8.6.2. The machinery should apply the technical requirements referred to in section 8.5, where applicable.

8.6.3. Dangerous movements of the carrier should be prevented, such as movement due to tipping or excessive acceleration and deceleration.

8.6.4. The worker being lifted should have control of the carrier movement.

8.6.5. Crushing and shearing risks should be controlled either by enclosure or a combination of slow speed and “hold to run” devices.

8.6.6. Means should be provided to rescue workers in the event of a breakdown or power failure.

8.6.7. In the case of hoists or lifts, carrier levels should be maintained and sufficiently accurate to prevent tripping risks.

8.6.8. Machinery should be equipped with devices, for example, lock-off, props and blocks to prevent crushing risks during maintenance work.

8.6.9. The carrier should be marked to show the number of people that can be carried and the safe working load.

Bibliography

The International Labour Conference has adopted a large number of international labour Conventions and accompanying Recommendations directly concerned with OSH issues. The ILO has also developed many codes of practice and technical publications applicable to OSH. They represent a body of definitions, principles, guidance, obligations, duties and rights, as well as technical guidance reflecting the consensual views of the ILO's tripartite constituents from its 185 member States on most aspects of OSH. In addition, this bibliography lists relevant standards in the field of machinery safety, but is not an exhaustive list.

1. Relevant ILO Conventions and Recommendations

1.1. Fundamental ILO Conventions and accompanying Recommendations

Eight Conventions were included by the International Labour Conference in the ILO Declaration on Fundamental Principles and Rights at Work. These eight Conventions cover the following four areas:

Freedom of association

- Freedom of Association and Protection of the Right to Organise Convention, 1948 (No. 87)
- Right to Organise and Collective Bargaining Convention, 1949 (No. 98)

The elimination of forced labour

- Forced Labour Convention, 1930 (No. 29)
- Abolition of Forced Labour Convention, 1957 (No. 105)

Safety and health in the use of machinery

The abolition of child labour

- Minimum Age Convention (No. 138) and Recommendation (No. 146), 1973
- Worst Forms of Child Labour Convention (No. 182) and Recommendation (No. 190), 1999

The elimination of discrimination

- Discrimination (Employment and Occupation) Convention (No. 111) and Recommendation (No. 111), 1958
- Equal Remuneration Convention (No. 100) and Recommendation (No. 90), 1951

1.2. Conventions and Recommendations on occupational safety and health and working conditions

- Labour Inspection Convention (No. 81) and Recommendation (No. 81), 1947
- Radiation Protection Convention (No. 115) and Recommendation (No. 114), 1960
- Guarding of Machinery Convention (No. 119) and Recommendation (No. 118), 1963
- Employment Injury Benefits Convention (No. 121) and Recommendation (No. 121), 1964
- Maximum Weight Convention (No. 127) and Recommendation (No. 128), 1967
- Workers' Representatives Convention (No. 135) and Recommendation (No. 143), 1971
- Working Environment (Air Pollution, Noise and Vibration) Convention (No. 148) and Recommendation (No. 156), 1977

- Occupational Safety and Health Convention, 1981 (No. 155) and Recommendation (No. 164), 1981
- Protocol of 2002 (recording and notification of occupational accidents and diseases) to the Occupational Safety and Health Convention, 1981 (No. 155)
- Occupational Health Services Convention (No. 161) and Recommendation (No. 171), 1985
- Chemicals Convention (No. 170) and Recommendation (No. 177), 1990
- Promotional Framework for Occupational Safety and Health Convention (No. 187) and Recommendation (No. 197), 2006
- List of Occupational Diseases Recommendation, 2002 (No. 194) (updated in 2010)

2. Selected ILO codes of practice with provisions which are relevant and applicable to safety and health in the use of machinery

- *Safety, health and working conditions in the transfer of technology to developing countries*, 1988
- *Safety and health in construction*, 1992
- *Safety in the use of chemicals at work*, 1993
- *Recording and notification of occupational accidents and diseases*, 1996
- *Safety and health in forestry work*, 1998
- *Safety and health in the non-ferrous metals industries*, 2001
- *Ambient factors in the workplace*, 2001

Safety and health in the use of machinery

- *Safety and health in the iron and steel industry*, 2005
- *Safety and health in agriculture*, 2011

3. Relevant publications

- ILO. 1998. Declaration on Fundamental Principles and Rights at Work and its Follow-up, International Labour Conference, 86th Session (Geneva).
- . 1998. *Encyclopaedia of occupational health and safety*, fourth edition (Geneva) (four-volume print version and CD-ROM).
- . 1998. *Technical and ethical guidelines for workers' health surveillance*, Occupational Safety and Health Series, No. 72 (Geneva).
- . 2001. *Guidelines on occupational safety and health management systems*, ILO–OSH 2001 (Geneva).
- . 2003. *Global strategy on occupational safety and health*, conclusions adopted by the International Labour Conference (Geneva).

4. Other technical standards

- IEC. 2005. IEC 62061, Safety of machinery – Functional safety of safety-related electrical, electronic and programmable electronic control systems.
- IEC. 2008. IEC 61496-1, Safety of machinery – Electro-sensitive protective equipment – Part 1: General requirements and tests.
- IEC. 2009. IEC 60204-1, Safety of machinery – Electrical equipment of machines – Part 1: General requirements.
- ISO. 1991. ISO 10075, Ergonomic principles related to mental workload – General terms and definitions.
- . 1996. ISO 10075-2, Ergonomic principles related to mental workload – Part 2: Design principles.

Bibliography

- 1996. ISO 11428, Ergonomics – Visual danger signals – General requirements, design and testing.
- 1996. ISO 13854, Safety of machinery – Minimum gaps to avoid crushing of parts of the human body.
- 1998. ISO 14119, Safety of machinery – Interlocking devices associated with guards – Principles for design and selection.
- 2000. ISO 14118, Safety of machinery – Prevention of unexpected start-up.
- 2001. ISO 14122, Safety of machinery – Permanent means of access to machinery.
- 2002. ISO 13851, Safety of machinery – Two-hand control devices – Functional aspects and design principles.
- 2002. ISO 14120, Safety of machinery – Guards – General requirements for the design and construction of fixed and movable guards.
- 2004. ISO 6385, Ergonomic principles in the design of work systems.
- 2005. ISO 13732-3, Ergonomics of the thermal environment – Methods for the assessment of human responses to contact with surfaces – Part 3: Cold surfaces.
- 2006. ISO 13732-1, Ergonomics of the thermal environment – Methods for the assessment of human responses to contact with surfaces – Part 1: Hot surfaces.
- 2006. ISO 13849-1, Safety of machinery – Safety-related parts of control systems – Part 1: General principles for design.
- 2007. ISO 13850, Safety of machinery – Emergency stop – Principles for design.

Safety and health in the use of machinery

- 2008. ISO 13857, Safety of machinery – Safety distances to prevent hazard zones being reached by upper and lower limbs.
- 2010. ISO 12100, Safety of machinery – General principles for design – Risk assessment and risk reduction.
- 2010. ISO 13855, Safety of machinery – Positioning of safeguards with respect to the approach speeds of parts of the human body.
- 2011. ISO 26800, Ergonomics – General approach, principles and concepts.

5. Other publications

European Commission, Enterprise and Industry. 2010. *Guide to application of the Machinery Directive 2006/42/EC* (second edition).

Appendices

The appendices are intended to be informative and provide more detailed guidance to assist designers and manufacturers and employers. Because the state of the art may change over time, enabling more effective measures to be provided, designers, manufacturers and employers should always refer to current specific guidance, starting with the bibliography, for example.

Appendix I

Types of different guarding for machinery

1. Methods of safeguarding machinery

1.1. There are many ways of safeguarding machinery. The type of operation, the size or shape of material being worked, the method of handling, the physical layout of the work area, and the type of material and production requirements or other limitations, all need to be considered in order to determine the appropriate safeguarding method for the individual machinery or integrated manufacturing system. Machine designers and manufacturers and safety professionals should choose the most effective and practical safeguard available.

1.2. Stop functions initiated by safeguards, such as interlocking devices or presence-sensing devices, are the safety function. The greater the dependence of risk reduction on the safety function, the higher the required integrity of the safety-related parts of control systems, including software, to resist faults and reliably perform safety functions. The appropriate design measures of control system and the proper selection of components used should therefore be applied to achieve a sufficient level of fault tolerance and risk reduction.

2. Safeguarding with guards

2.1. There are many types of guard. Barrier guards are usually the first safeguarding method considered for machines. When a guard is used as the primary safeguarding method, it should be designed, constructed, adjusted and maintained so that a person cannot reach around, under, through or over the guard. A guard opening scale is a valuable tool to use during the design, installation and inspection of guards, in accordance with national law and practice. The following are representative examples of guards.

2.1.1. Fixed guards

2.1.1.1 A fixed guard is a permanent part of the machinery and is not dependent on moving parts to perform its intended function. It should be constructed of sheet metal, screen, wire mesh, bars, plastic or any other material that is substantial enough to withstand whatever impact it may receive and to endure prolonged use. Fixed guards are usually preferable to all other types because of their relative simplicity and permanence. It should not be possible to remove them without the use of a tool.

Fixed guards have no moving parts and are fastened in a constant position relative to the danger zone.

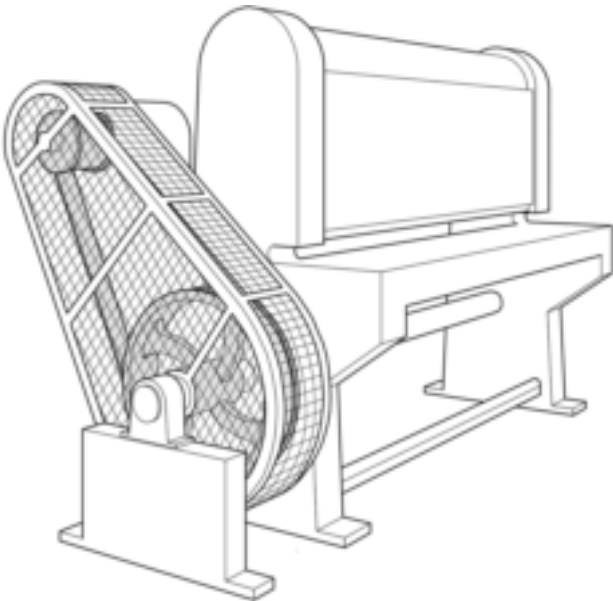

Safety and health in the use of machinery

2.1.2. Interlocking guards

2.1.2.1 When interlocking guards are opened or removed, the switch or interlock automatically stops the hazardous motion or power source or disconnects the drive power, and the machinery cannot cycle or be started until the interlocking guard is back in place. Replacing the interlocking guard should not, however, automatically restart the machinery. Interlocking guards may use electrical, mechanical, hydraulic or pneumatic power, or any combination of these. Interlocks

When an interlocking guard is opened or removed, the tripping mechanism and/or power supply to the dangerous part or hazardous machine function covered by the guard automatically shuts off or disengages. The dangerous part or hazardous function cannot operate until the guard is back in place and closed, but closure of the guard does not automatically initiate operation of the dangerous part or hazardous motion.

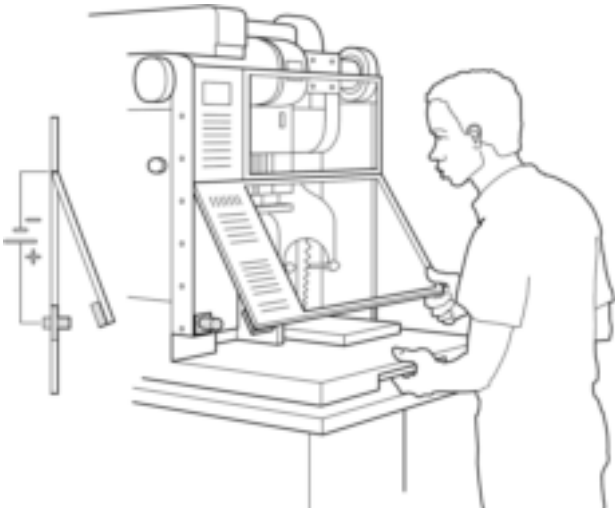

should not prevent “inching” (gradual progressive movements) for a specific area if additional controls are in place, such as hold-to-run buttons. Consideration should be given to the position and selection of the interlocking guard, its characteristics (response time) and those of the machinery to which it is fitted (time needed to stop) to make sure that it is sufficient to ensure safety.

2.1.3. Interlocking guard with guard locking

2.1.3.1. In situations where an interlocking guard can be opened and the time needed to stop the hazardous operation is not sufficient to prevent unsafe access, interlocking guards with guard locking should be used. The locking system keeps the guard closed and locked until the risk of injury from hazardous machinery functions has ceased.

2.1.4. Adjustable guards

2.1.4.1. Manually adjustable guards

Manually adjustable guards are guards whose opening can be adjusted and then fixed to suit the size of material being introduced into the point of operation. Adjustable guards offer varying degrees of protection. Refer to paragraph 5.10.2 of the code.

2.1.4.2. Self-adjusting guards

The openings of self-adjusting guards are determined by the movement of the material. As the operator moves the material into the danger area, the guard is pushed away, providing an opening sufficiently large to admit only the material. After the material is removed, the guard returns to the rest position. This guard protects the operator by placing a barrier between the danger area and the operator. The guards may be constructed of plastic, metal or other substantial material. Self-adjusting guards offer varying degrees of protection.

Safety and health in the use of machinery

Adjustable guards allow flexibility to accommodate the various sizes and shapes of the stock.

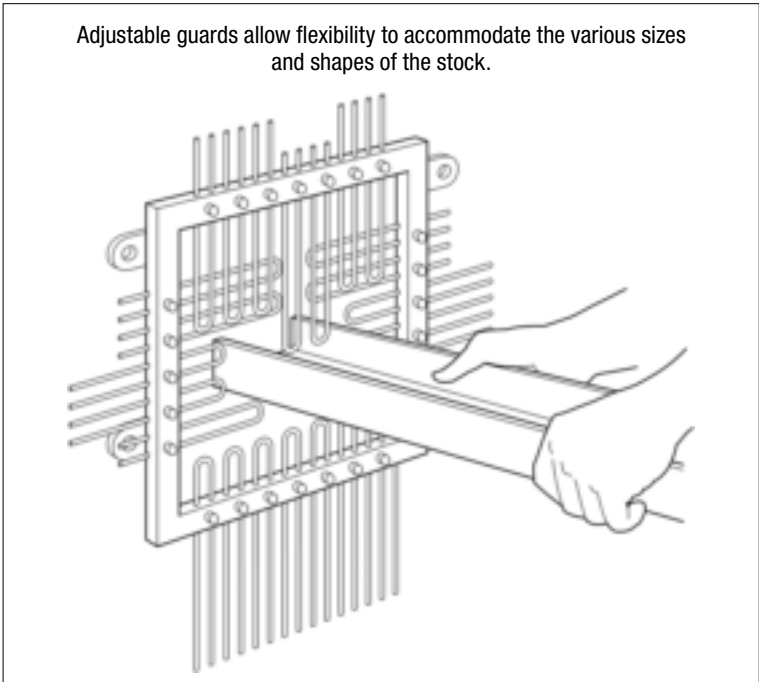

3. Safeguarding with protective devices

3.1. General description

3.1.1. Protective devices may stop the functions of machinery if any part of the body is inadvertently placed in the hazard zone, or may require the removal of the operator from the danger area before a cycle is started. They may provide a virtual barrier in accordance with the operating cycle of the machinery in order to prevent access to the danger area during the hazardous part of the cycle, or may require

the worker operating the machinery to use both hands on machinery controls simultaneously (thus keeping both hands and body out of danger).

3.1.2. It should be noted that since protective devices are not physical barriers, they are not appropriate where protection is required against hazards such as extremes of temperature, noise emissions, dust, fumes, etc.

3.2. Performance

3.2.1. In order to ensure that the hazard zone cannot be reached before the hazardous function of machinery has ceased when a protective device initiates a stop function, an appropriate minimum distance, based on the response time of the stop function, needs to be provided between the positions of the protective device and the hazard zone.

3.3. Braking and stopping

3.3.1. In addition, any machinery fitted with a protective device should be fitted with a device such as a brake or other reliable means for stopping the machinery before the hazard zone can be reached. In this case, it is important that the brake performs consistently (for example, brake pad wear needs to be considered in the case of mechanical brakes). Where the deterioration of that performance is critical to intended risk reduction, stopping performance should be monitored by any suitable mechanisms or control systems so that if the stopping time exceeds an allowed level, further start-up can be prevented.

3.4. Basic types of protective devices

3.4.1. Presence-sensing devices

3.4.1.1. Three types of sensing devices which stop machinery or interrupt the work cycle or operation if a worker is within the danger zone are described below.

Safety and health in the use of machinery

3.4.1.2. *Photoelectric or optical presence-sensing devices* use a system of light sources and controls which can interrupt the machinery's operating cycle. If the light field is broken, the machine stops and will not cycle. Such devices should be used only on machines which can be stopped before workers reach the danger area. The device may be swung up or down to accommodate different production requirements.

3.4.1.3. *Vision systems* use a system of cameras linked to a complex logic unit that can monitor the presence of persons and adjust the area which will lead to a signal or stopping of the machine, depending on the machine operation going on at any given time. The system normally warns persons against approaching the danger areas and will stop the machine if the danger area is reached. At present, this is new technology and standards are currently under preparation.

3.4.1.4. *Pressure-sensitive mats*, when depressed, will deactivate the machinery. They can be used to prevent a machine from starting when a worker is in a hazard zone and stop the machinery if a person moves into that zone. The positioning of the mat is critical, as it needs to stop the machinery before a part of the body reaches the hazard zone.

3.4.2. Safety control devices

3.4.2.1. All of the following safety control devices are activated manually and should be manually reset to restart the machinery.

3.4.2.2. Two-hand controls require constant, concurrent pressure for the operator to activate the machinery. With this type of device, the operator's hands are required to be at a safe location (on control buttons) and at a safe distance from the danger area while the machinery completes its hazardous function. The machine should be designed in such a way that removing the hand from either control stops the

hazardous function. Two-hand controls should be used in combination with other forms of safeguarding to prevent other workers gaining access to the hazardous function.

3.4.2.3. An enabling device is an additional manually operated device used in conjunction with a start control and which, when continuously actuated, allows machinery to function.

3.4.2.4. A hold-to-run control is a control which initiates and maintains a certain type of machinery function only as long as the manual control or the actuator is actuated.

4. Other protective measures

4.1. All of these other protective measures are activated manually and should be manually reset to restart the machinery.

4.2. Safety trip controls such as pressure bars, trip rods and tripwires are manual controls which provide a quick means of deactivating the machinery in an emergency situation.

- (a) Pressure-sensitive body bars, trip rods and tripwires, when activated, will stop the machinery if the operator or anyone trips, loses balance or is drawn toward the machinery. The positioning of the bar, trip rod or tripwire is critical, as it needs to stop the machinery before a part of the body reaches the danger area.
- (b) Trip rods deactivate the machinery when pressed by hand. Since they have to be actuated by the worker operating machinery during an emergency situation, correct positioning is critical.
- (c) Tripwire cables are located around the perimeter or in the vicinity of the danger area. The operator should be able to reach the cable with either hand to stop the machinery.

5. Emergency stops

5.1. An emergency stop is not a substitute for other safeguarding measures but is intended to stop the machine in a safe and reliable way. It should not be used instead of isolation measures when maintenance is carried out. An emergency stop is:

- (a) initiated by a single human action;
- (b) manually reset prior to restarting of the machinery; and
- (c) available and operational at all times, regardless of the operating mode.

Appendix II

Detailed supplementary technical information for certain specific machinery types

1. Supplementary information to offset hazards due to the mobility of machinery (such as vehicles, earth-moving machinery, excavators, harvesters and tractors)

1.1. General considerations

1.1.1. If work can be done properly only by workers on foot, appropriate measures should be taken to prevent them from being injured by machinery.

1.1.2. Transportation of workers on mechanically driven mobile machinery should be authorized only where safe facilities are provided for that purpose. If work needs to be carried out while equipment is in motion, the speed should be adjusted as necessary to ensure the safety of workers.

1.2. Work positions

1.2.1. Driving position

1.2.1.1. Visibility from the driving position should be such that drivers can, in complete safety for themselves and the exposed persons, operate the machinery and its tools in the expected conditions of use. Where necessary, appropriate devices should be provided to remedy hazards due to inadequate direct vision.

1.2.1.2. Machinery on which the driver is transported should be designed and constructed in such a way that, from the driving positions, there is no risk to the driver from inadvertent contact with the wheels and tracks.

Safety and health in the use of machinery

1.2.1.3. The driving position of ride-on drivers should be designed and constructed in such a way that a driver's cab may be fitted, provided this does not increase any form of risk. The cab should incorporate a place for the instructions needed by the driver.

1.2.2. Seating

1.2.2.1. Where there is a risk that operators or other persons transported by the machinery may be crushed between parts of the machinery and the ground in the event that the machinery rolls or tips over, in particular for machinery equipped with a protective structure, their seats should be designed or equipped with a restraint system so as to keep them in their seats, without restricting any movements necessary for operations or movements relative to the structure caused by the suspension of the seats. Such restraint systems should not be fitted if they increase the risk.

1.2.3. Positions for other persons

1.2.3.1. If the conditions of use provide that persons other than the driver may occasionally or regularly be transported by the machinery or work on it, appropriate positions should be provided which enable them to be transported or to work on it without risk.

1.3. Control systems

1.3.1. General considerations

1.3.1.1. Steps should be taken to prevent unauthorized use of controls.

1.3.1.2. In the case of remote controls, each control unit should clearly identify the machinery to be controlled from that unit.

1.3.1.3. The remote control system should be designed and constructed in such a way as to affect only:

- (a) the machinery in question; and
- (b) the functions in question.

1.3.1.4. Remote-controlled machinery should be designed and constructed in such a way that it will respond only to signals from the intended control units.

1.3.2. Control devices

1.3.2.1. The driver should be able to actuate all control devices required to operate the machinery from the driving position, except for functions which can only be safely actuated by using control devices located elsewhere. These functions include, in particular, those for which operators other than the driver are responsible or for which the driver has to leave the driving position in order to control them safely.

1.3.2.2. Where there are pedals, they should be so designed, constructed and fitted as to allow safe operation by the driver with the minimum risk of incorrect operation. They should have a slip-resistant surface and be easy to clean.

1.3.2.3. Where the operation of control devices can give rise to hazards, notably dangerous movements, they should return to the neutral position as soon as they are released by the operator (except those with preset positions).

1.3.2.4. In the case of wheeled machinery, the steering system should be designed and constructed in such a way as to reduce the force of sudden movements of the steering wheel or steering lever caused by shocks to the guide wheels.

1.3.2.5. Any control that locks the machinery differential should be so designed and arranged that it allows the differential to be unlocked when the machinery is moving.

Safety and health in the use of machinery

1.3.2.6. Acoustic and visual warning signals should be provided for reversing.

1.3.3. Starting and moving

1.3.3.1. All travel movements of self-propelled machinery with a ride-on driver should be possible only if the driver is at the controls.

1.3.3.2. Where, for operating purposes, machinery is fitted with devices that exceed its normal clearance zone, for example stabilizers and jibs, the driver should be provided with means of checking easily, before moving the machinery, that such devices are in a specified position which allows safe movement.

1.3.3.3. This also applies to all other parts which have to be in particular positions or locked in order to allow safe movement.

1.3.3.4. Where it does not give rise to other risks, movement of the machinery should depend on safe positioning of the parts referred to in 1.3.3.3.

1.3.3.5. It should not be possible for unintentional movement of the machinery to occur while the engine is being started.

1.3.4. Travelling function

1.3.4.1. Without prejudice to road traffic regulations, self-propelled machinery and its trailers should meet the requirements referred to in 1.3.4.2 for slowing down, stopping, braking and immobilization so as to ensure safety under all foreseen operating, load, speed, ground and gradient conditions.

1.3.4.2. The driver should be able to slow down and stop self-propelled machinery by actuating a main device. Where safety so requires, in the event of a failure of the main device or in the absence of the energy supply needed to actuate it, an emergency device with a

fully independent and easily accessible control device should be provided for slowing down and stopping.

1.3.4.3. For safety reasons, a parking device should be provided to render stationary machinery immobile. This device may be combined with one of the devices referred to in 1.3.4.2, provided that it is purely mechanical.

1.3.4.4. Remote-controlled machinery should be equipped with devices for stopping operation automatically and immediately and for preventing potentially dangerous operation in the following situations:

- (a) if the driver loses control;
- (b) if a stop signal is received;
- (c) if a fault is detected in a safety-related part of the system; or
- (d) if no validation signal is detected within a specified time.

1.3.5. Movement of pedestrian-controlled (“walk-behind”) machinery such as lawnmowers and renovators

1.3.5.1. Movement of pedestrian-controlled self-propelled machinery should be possible only through sustained action on the relevant control device by the driver. In particular, it should not be possible for movement to occur while the engine is being started.

1.3.5.2. Control systems for pedestrian-controlled machinery should be designed in such a way as to minimize the risks arising from inadvertent movement of the machinery towards the driver, in particular:

- (a) crushing; and
- (b) injury from rotating tools.

Safety and health in the use of machinery

1.3.5.3. The speed of travel of the machinery should be compatible with the pace of a driver on foot.

1.3.5.4. In the case of machinery on which a rotary tool may be fitted, it should not be possible to actuate the tool when the reverse control is engaged, except where the movement of the machinery is a result of movement of the tool. In the latter case, the reversing speed should be such that it does not endanger the driver.

1.3.6. Control circuit failure

1.3.6.1. A failure in the power supply to power-assisted steering should not prevent machinery from being steered during the time required to stop it.

1.4. Protection against mechanical hazards

1.4.1. Uncontrolled movements

1.4.1.1. Machinery should be designed, constructed and, where appropriate, positioned on its mobile support in such a way as to ensure that, when moved, uncontrolled oscillations of its centre of gravity do not affect its stability or exert excessive strain on its structure.

1.4.2. Moving transmission parts

1.4.2.1. In the case of engines, movable guards preventing access to the moving parts in the engine compartment need not have interlocking devices if they have to be opened either by the use of a tool or key or by a control located in the driving position, providing that the latter is in a fully enclosed cab with a lock to prevent unauthorized access.

1.4.3. Roll-over and tip-over

1.4.3.1. In the case of self-propelled machinery with a ride-on driver, operators or other persons, if there is a risk of rolling or tipping

over, the machinery should be fitted with an appropriate protective structure, unless such a structure increases the risk.

1.4.3.2. The protective structure should be such that in the event of rolling or tipping over, it affords the ride-on persons an adequate deflection-limiting volume.

1.4.3.3. In order to verify that the structure complies with the requirements described in paragraph 1.4.3.2 above, the manufacturer should, for each type of structure concerned, perform appropriate tests.

1.4.4. Falling objects

1.4.4.1. Where, in the case of self-propelled machinery with a ride-on driver, operators or other persons, there is a risk due to falling objects or material especially when performing lifting, the machinery should be designed and constructed in such a way as to take account of this risk and fitted, if its size allows, with an appropriate protective structure.

1.4.4.2. This structure should be such that, in the event of falling objects or material, it guarantees the ride-on persons adequate protection.

1.4.4.3. In order to verify that the structure complies with the requirement described in paragraph 1.4.4.2 above, the manufacturer should, for each type of structure concerned, perform appropriate tests or have such tests performed.

1.4.5. Means of access

1.4.5.1. Handholds (handrails) and steps should be designed, constructed and arranged in such a way that operators use them instinctively and do not use the control devices to facilitate access.

Safety and health in the use of machinery

1.4.6. Towing devices

1.4.6.1. All machinery used for towing should be fitted with towing or coupling devices designed, constructed and arranged in such a way as to ensure easy and secure connection and disconnection and to prevent accidental disconnection during use.

1.4.6.2. The tow bar load requires towed machinery to be equipped with a support with a bearing surface suited to the load and the ground.

1.4.7. Transmission of power between self-propelled machinery (or tractor) and recipient machinery

1.4.7.1. Removable mechanical transmission devices linking self-propelled machinery (or a tractor) to the first fixed bearing of recipient machinery should be designed and constructed in such a way that any part that moves during operation is protected over its entire length.

1.4.7.2. On the side of the self-propelled machinery (or tractor), the power take-off to which the removable mechanical transmission device is attached should be protected either by a fixed guard linked to the self-propelled machinery (or tractor) or by any other device offering equivalent protection.

1.4.7.3. It should be possible to open this guard in order to gain access to the removable transmission device. Once it is in place, there should be enough room to prevent the drive shaft from damaging the guard when the machinery (or tractor) is moving.

1.4.7.4. On the recipient machinery side, the input shaft should be enclosed in a protective casing fixed to the machinery.

1.4.7.5. Torque limiters or freewheels may be fitted to universal joint transmissions only on the side adjoining the machinery being driven. The removable mechanical transmission device should be marked accordingly.

1.4.7.6. All recipient machinery which, to be operated, requires a removable mechanical transmission device to connect it to self-propelled machinery (or tractor), should have a system for attaching the removable mechanical transmission device so that, when the machinery is uncoupled, the removable mechanical transmission device and its guard are not damaged by contact with the ground or with part of the machinery.

1.4.7.7. The outside parts of the guard should be so designed, constructed and arranged that they cannot rotate with the removable mechanical transmission device. The guard should cover the transmission to the ends of the inner jaws (in the case of simple universal joints) and at least to the centre of the outer joint or joints (in the case of wide-angle universal joints as well as torque limiters and wheels).

1.4.7.8. If means of access to working positions are provided near the removable mechanical transmission device, they should be designed and constructed in such a way that the shaft guards cannot be used as steps, unless they are designed and constructed with that possibility in mind.

1.5. Protection against other hazards

1.5.1. Batteries

1.5.1.1. The battery housing should be designed and constructed in such a way as to prevent electrolyte being ejected onto the operator in the event of rollover or tip-over and to avoid the accumulation of vapours in places occupied by operators.

1.5.1.2. Machinery should be designed and constructed in such a way that the battery can be disconnected with the aid of an easily accessible device provided for that purpose.

1.5.1.3. Battery charging should be carried out in well-ventilated areas to prevent a build-up of hydrogen gas.

Safety and health in the use of machinery

1.5.2. Fire

1.5.2.1. Depending on the hazards anticipated by the manufacturer, machinery should, where its size permits:

- (a) allow easily accessible fire extinguishers to be fitted; or
- (b) be provided with built-in extinguisher systems.

1.6. Information and indications

1.6.1. Signs, signals and warnings

1.6.1.1. All machinery should have signs and instruction plates concerning use, adjustment and maintenance so as to ensure the health and safety of persons. They should be chosen, designed and constructed in such a way as to be clearly visible as well as indelible.

1.6.1.2. Written signs and instruction plates should be in the official language(s) of the country where the machinery is to be used, and the supplier should also include accurate translations into other languages in widespread use in that country.

1.6.1.3. Without prejudice to the provisions of road traffic regulations, machinery with a ride-on driver should have the following equipment:

- (a) an acoustic warning device to alert persons;
- (b) a system of light signals relevant to the intended conditions of use (this requirement does not apply to machinery intended solely for use underground and having no electrical power);
- (c) where necessary, appropriate connections should be provided between a trailer and the machinery for the operation of signals.

1.6.1.4. Remote-controlled machinery which, under normal conditions of use, exposes persons to the risk of impact or crushing should

be fitted with appropriate means to signal its movements or with means to protect workers against such risks. The same applies to machinery which, when in use, involves the constant repetition of a forward and backward movement on a single axis where the area to the rear of the machinery is not directly visible to the driver.

1.6.1.5. Machinery should be constructed in such a way that the warning and signalling devices cannot be disabled unintentionally. Where it is essential for safety, such devices should be provided with means to check that they are in good working order, and their failure should be made apparent to the worker.

1.6.1.6. Where the movement of machinery or its tools is particularly hazardous, signs on the machinery should be provided to warn against approaching the machinery while it is working; the signs should be legible at a sufficient distance to ensure the personal safety of those who have to be in the vicinity.

1.6.2. Marking

1.6.2.1. The following information should be shown legibly and indelibly on all machinery:

- (a) the nominal power, expressed in kilowatts (kW);
- (b) the weight of the machinery in its most usual configuration, expressed in kilograms (kg); and,
where appropriate:
- (c) the maximum drawbar pull provided for at the coupling hook, in newtons (N);
- (d) the maximum vertical load provided for on the coupling hook, in newtons (N).

Safety and health in the use of machinery

2. Technical information to offset hazards due to lifting operations (such as those involving cranes or hoists)

2.1. General

2.1.1. The lifting device should be of sufficient capacity and suitable for the purpose of lifting.

2.1.2. A lifting device which is either mobile or capable of being dismantled and which is designed for lifting loads should be used in such a way as to ensure its stability during use under all foreseeable conditions. The nature of the ground should also be taken into account.

2.1.3. The maximum permissible load of the lifting device should not be exceeded.

2.1.4. When two or more items of machinery used for lifting non-guided loads are installed or erected on a site in such a way that their working radii overlap, appropriate measures should be taken to prevent collisions between the loads and the machinery parts themselves.

2.1.5. When using mobile machinery for lifting non-guided loads, measures should be taken to prevent the equipment from tilting, overturning, moving or slipping. Checks should be made to ensure that these measures are implemented properly.

2.1.6. If the operators of machinery designed for lifting non-guided loads cannot observe the full path of the load either directly or by means of auxiliary equipment, a competent person should be in communication with the operators to guide them. Organizational measures should be taken to prevent collisions involving the load which could endanger workers.

2.1.7. Work should be organized in such a way that a worker can safely attach or detach a load by hand, in particular by ensuring that workers retain direct or indirect control of the machinery.

2.1.8. In particular, if a load has to be lifted by two or more pieces of machinery for lifting non-guided loads simultaneously, a procedure should be established and applied to ensure good coordination on the part of the operators.

2.1.9. Measures should be taken to ensure that workers are not present underneath suspended loads, unless their presence there is required for the effective performance of the work.

2.1.10. If machinery designed for lifting non-guided loads cannot maintain its hold on the load in the event of a complete or partial power failure, appropriate measures should be taken to avoid exposing workers to any resultant risks.

2.1.11. Suspended loads should not be left without surveillance unless access to the danger zone is prevented and the load has been safely suspended and is safely held.

2.1.12. Outdoor machinery designed for lifting non-guided loads should not continue when meteorological conditions deteriorate to the point of jeopardizing the safe use of the equipment and exposing workers to risks. Adequate protection measures, in particular to prevent the machinery from turning over, should be taken to prevent any risks to workers.

2.1.13. Loads should not normally be moved above unprotected workplaces that are usually occupied by workers. Where that is absolutely unavoidable because the work cannot be carried out properly in any other way, appropriate procedures should be established and applied.

2.1.14. Machinery presenting hazards due to lifting operations should meet all the relevant health and safety requirements described in sections 2.2–2.11.

Safety and health in the use of machinery

2.2. Protection against mechanical hazards

2.2.1. Risks due to lack of stability

2.2.1.1. Machinery should be designed and constructed in such a way that its stability is maintained both in and out of service, including at all stages of transportation, assembly and dismantling, during foreseeable component failures, and during any tests carried out in accordance with the instruction handbook (operator's manual).

2.2.2. Machinery running on guide rails and rail tracks

2.2.2.1. Machinery should be provided with devices which act on the guide rails or tracks to prevent derailment.

2.2.2.2. If, despite such devices, there remains a risk of derailment or of failure of a rail or of a running component, devices should be provided to prevent the equipment, component or load from falling or the machinery from overturning.

2.2.3. Mechanical strength

2.2.3.1. Machinery, lifting accessories and their components should be capable of withstanding the stresses to which they are subjected whether in use or not in use, under the installation and operating conditions provided for and in all relevant configurations, with due regard to any potential effects of conditions of use and forces exerted by persons. This requirement should also be satisfied during transport, assembly and dismantling.

2.2.3.2. Machinery and lifting accessories should be designed and constructed in such a way as to prevent failure from fatigue and wear, taking due account of their intended use.

2.2.3.3. The materials used should be chosen in the light of the intended working environments, with particular regard to factors such

as corrosion, abrasion, impacts, extreme temperatures, fatigue, brittleness and ageing.

2.2.3.4. Machinery and lifting accessories should be designed and constructed in such a way as to withstand the overload applied in the static tests without permanent deformation or discernible defect. Strength calculations should take account of the value of the static test coefficient chosen to guarantee an adequate level of safety in accordance with established standards.

2.2.3.5. Machinery should be designed and constructed in such a way as to undergo, without failure, the dynamic tests carried out using the maximum working load multiplied by the dynamic test coefficient. This dynamic test coefficient is chosen so as to guarantee an adequate level of safety in accordance with established standards and the test should be performed at the nominal speeds provided for. Should the control circuit of the machinery allow for a number of simultaneous movements, the tests should be carried out under the least favourable conditions, usually involving a combination of movements.

2.3. Pulleys, drums, wheels, ropes and chains (refer to paragraphs 8.5.5 and 8.5.6 of the code)

2.3.1. Pulleys, drums and wheels should have a diameter commensurate with the size of the ropes or chains with which they can be fitted.

2.3.2. Drums and wheels should be designed, constructed and installed in such a way that the ropes or chains with which they are equipped can be wound without coming off.

2.3.3. Ropes used directly for lifting or supporting the load should not include any splicing other than at their ends. Splicing is, however, acceptable in installations which by design are intended to be modified regularly according to need.

Safety and health in the use of machinery

2.3.4. Ropes and their endings should have a working coefficient chosen in such a way as to guarantee an adequate level of safety.

2.3.5. Lifting chains should have a working coefficient chosen in such a way as to guarantee an adequate level of safety.

2.3.6. In order to verify that an adequate working coefficient has been obtained, the manufacturer should perform the appropriate tests for each type of chain and rope used directly for lifting loads as well as for the rope ends.

2.4. Lifting accessories and their components

(refer to paragraphs 8.5.5 and 8.5.6 of the code)

2.4.1. Lifting accessories should be selected with due regard to the expected loads on handling and gripping points, the attachment tackle and the atmospheric conditions, and taking into account the configuration of slinging. Lifting accessories should be clearly marked so that users are aware of their characteristics where they are not dismantled after use.

2.4.2. Lifting accessories should be stored in such a way as to ensure that they will not be damaged or degraded.

2.4.3. Lifting accessories and their components should be sized with due regard to the fatigue and ageing processes likely to result from a number of operating cycles consistent with their expected lifespan as specified in the operating conditions for a given application.

2.4.4. The working coefficient of wire-rope/rope-end combinations should be chosen in such a way as to guarantee an adequate level of safety in accordance with established standards. Ropes should not comprise any splices or loops other than at their ends.

2.4.5. Where chains with welded links are used, they should be of the short link type. The working coefficient of chains should

be chosen in such a way as to guarantee an adequate level of safety.

2.4.6. The working coefficient for textile ropes or slings depends on the material, method of manufacture, dimensions and use. The coefficient chosen should be such that an adequate level of safety is guaranteed, provided that the materials used are of proven high quality and the method of manufacture is appropriate to the intended use. Should that not be the case, the coefficient should, as a general rule, be set at a higher level in order to secure an equivalent level of safety. Textile ropes and slings should not include any knots, connections or splicing other than at the ends of the sling, except in the case of an endless sling.

2.4.7. All metallic components that are part of or used with a sling should have a working coefficient chosen in such a way as to guarantee an adequate level of safety.

2.4.8. The maximum working load of a multi-legged sling should be determined on the basis of the working coefficient of the weakest leg, the number of legs, and a reduction factor which depends on the slinging configuration.

2.4.9. In order to verify that an adequate working coefficient has been attained, the manufacturer should, for each type of component referred to in paragraphs 2.4.4–2.4.7, perform the appropriate tests or have such tests performed.

2.5. Control of movements

2.5.1. Devices for controlling movements should perform in such a way that the machinery on which they are installed is kept safe.

2.5.2. Machinery should be designed and constructed or fitted with devices in such a way that the amplitude of movement of its components is kept within the specified limits. The operation of such devices should, where appropriate, be preceded by a warning.

Safety and health in the use of machinery

2.5.3. Where several fixed or rail-mounted units of machinery can be manoeuvred simultaneously in the same place so as to pose a risk of collision, the machinery should be designed and constructed in such a way as to allow the fitting of systems to prevent such risks.

2.5.4. Machinery should be designed and constructed in such a way that loads cannot creep dangerously or fall freely or unexpectedly, even in the event of partial or total failure of the power supply or if the operator stops operating the machinery.

2.5.5. It should not be possible under normal operating conditions to lower the load solely by friction brake, except in the case of machinery whose function requires it to operate in that way.

2.5.6. Holding devices should be designed and constructed in such a way that inadvertent dropping of loads is avoided.

2.6. Movements of loads during handling

2.6.1. Machinery during operation should be positioned in such a way as to ensure the widest possible view of the moving parts and their trajectories so as to avoid possible collisions with persons, equipment or other machinery which might be moving at the same time, thus creating a potential hazard.

2.6.2. Machinery with guided loads should be designed and constructed in such a way as to prevent injury to persons resulting from the movement of the load, the carrier or any counterweights.

2.7. Machinery serving fixed landings

2.7.1. Movements of the carrier

2.7.1.1. The movement of the carrier of machinery serving fixed landings should be rigidly guided to and at the landings. Scissor systems are also regarded as rigid guidance.

2.7.2. Access to the carrier

2.7.2.1. Where persons have access to the carrier, the machinery should be designed and constructed in such a way as to ensure that the carrier remains stationary during access, in particular while it is being loaded or unloaded.

2.7.2.2. The machinery should be designed and constructed in such a way as to ensure that the difference in level between the carrier and the landing being served does not create a risk of tripping.

2.7.3. Risks due to contact with the moving carrier

2.7.3.1. The travel zone should be rendered inaccessible during normal operation.

2.7.3.2. If during inspection or maintenance there is a risk that persons situated above or below the carrier may be crushed between it and any of the fixed parts, sufficient free space should be provided in the form of physical refuges, or mechanical devices should be provided to block the movement of the carrier.

2.7.4. Risk of loads falling off the carrier

2.7.4.1. Where there is a risk of a load falling off the carrier, the machinery should be designed and constructed in such a way as to prevent that risk.

2.7.5. Landings

2.7.5.1. The risk of persons on landings coming into contact with the moving carrier or other moving parts should be prevented.

2.7.5.2. Where there is a risk of persons falling into the travel zone when the carrier is not positioned on the landings, guards should be fitted in order to prevent this risk. Such guards should not open in the direction of the travel zone. They should be fitted with an interlocking device, controlled by the position of the carrier, to prevent:

Safety and health in the use of machinery

- (a) hazardous movements of the carrier until the guards are closed and locked; and
- (b) hazardous opening of a guard until the carrier has stopped at the corresponding landing.

2.7.6. Fitness for purpose

2.7.6.1. When lifting machinery or its lifting accessories are put on the market or used for the first time, the manufacturer should make sure that the appropriate measures are taken to ensure that the machinery and its accessories – whether manually or power-operated – can fulfil their specified functions safely.

2.7.6.2. The static and dynamic tests described in section 2.2.3 (mechanical strength) should be performed on all lifting machinery that is ready to be put into service.

2.7.6.3. Where the machinery cannot be assembled in the manufacturer's premises or in the premises of the manufacturer's authorized representative, the appropriate measures should be taken at the place of use. If it is possible for the machinery to be assembled at the manufacturer's premises or at the place of use, the safety measures may be carried out there.

2.8. Information for machinery with a power source other than human effort

2.8.1. Control of movements

2.8.1.1. Hold-to-run control devices should be used to control the movements of the machinery or its associated equipment. However, for partial or complete movements in which there is no risk of the load or the machinery colliding, these devices may be replaced with control devices authorizing automatic stops at pre-selected positions without the operator holding a hold-to-run control device.

2.8.2. Loading control

2.8.2.1. Machinery with a large maximum working load (for example over 1,000 kg) or a large overturning moment (for example of not less than 40,000 newton metres – Nm) should be fitted with devices to warn the driver and prevent dangerous movements in the event:

- (a) of overloading, as a result of either the maximum working load or the maximum working moment due to the load being exceeded; or
- (b) of the overturning moment being exceeded.

2.8.3. Installations guided by ropes

2.8.3.1. Rope carriers, tractors or tractor carriers should be held by counterweights or by a device allowing permanent control of the tension.

2.9. Information on use

2.9.1. Chains, ropes and webbing

(refer to paragraphs 8.5.5 and 8.5.6 of the code)

2.9.1.1. Each length of lifting chain, rope or webbing not forming part of an assembly should bear a mark or, where this is not possible, a plate or irremovable ring bearing the name and address of the manufacturer and the identifying reference of the relevant certificate.

2.9.1.2. The certificate referred to above should show at least the following information:

- (a) the name and address of the manufacturer;
- (b) a description of the chain or rope including:
 - (i) its nominal size;
 - (ii) its construction;

Safety and health in the use of machinery

- (iii) the material from which it is made; and
- (iv) any special metallurgical treatment applied to the material;
- (c) the test method used; and
- (d) the maximum load to which the chain or rope can be subjected in service. A range of values may be given on the basis of the intended applications.

2.9.2. Lifting accessories

(refer to paragraphs 8.5.5 and 8.5.6 of the code)

2.9.2.1. Lifting accessories should show the following particulars:

- (a) the material of which they are made, where this information is needed to ensure safe use; and
- (b) the maximum working load.

2.9.2.2. In the case of lifting accessories on which marking is physically impossible, the particulars referred to in 2.9.2.1 should be displayed on a plate or other equivalent means and securely affixed to the accessory.

2.9.2.3. The particulars should be legible and located in a place where they are not liable to disappear as a result of wear or jeopardize the strength of the accessory.

2.9.3. Lifting machinery

2.9.3.1. The maximum working load should be prominently marked on the machinery. This marking should be legible, indelible and in an unencoded form.

2.9.3.2. Where the maximum working load depends on the configuration of the machinery, each operating position should be provided with a load plate indicating the working load permitted for each configuration, preferably in the form of diagrams or tables.

2.9.3.3. Machinery intended for lifting goods only and equipped with a carrier allowing access to persons should bear a clear and indelible warning prohibiting the lifting of persons. This warning should be visible at each place where access is possible.

2.10. Instructions for lifting accessories

(refer to paragraphs 8.5.5 and 8.5.6 of the code)

2.10.1. Each lifting accessory or each commercially indivisible batch of lifting accessories should be accompanied by instructions setting out at least the following particulars:

- (a) the intended use;
- (b) the limits of use (particularly for lifting accessories such as magnetic or vacuum pads);
- (c) instructions for assembly, use and maintenance; and
- (d) the static test coefficient used.

2.11. Instructions for lifting machinery

2.11.1. Lifting machinery should be accompanied by instructions containing information on:

- (a) the technical characteristics of the machinery, and in particular:
 - (i) the maximum working load and, where appropriate, a copy of the load plate or load table indicating the working load for each configuration, preferably in the form of diagrams or tables;
 - (ii) the reactions at the supports or anchors and, where appropriate, characteristics of the tracks;
 - (iii) where appropriate, the definition and the method of installing the ballast;

Safety and health in the use of machinery

- (b) the contents of the logbook, if the logbook is not supplied with the machinery;
- (c) advice for operators in order to offset the lack of direct vision of the load;
- (d) where appropriate, a test report detailing the static and dynamic tests carried out by, or for, the manufacturer;
- (e) for machinery which is not fully assembled on the manufacturer's premises, the necessary instructions for carrying out the measures needed to ensure that they can fulfil their specified functions safely. This includes instructions on performing the necessary static and dynamic tests before the machinery is first put into service.

3. Supplementary safety information for machinery presenting particular hazards due to the lifting of persons

3.1. General

3.1.1. Persons should be lifted only by machinery and accessories that are designed and manufactured for this purpose.

3.1.2. Machinery (such as lift-trucks and cranes) which is not specifically designed for the purpose of lifting persons may exceptionally be used for that purpose in accordance with national law and practice, provided that appropriate measures have been taken through adequate supervision to ensure safety. A cage designed and manufactured for this purpose and a crane or lift-truck of sufficient stability and lifting capacity should be used. In accordance with national law and practice, further personal safety measures may be required to prevent falling from the cage. The maximum loading capacity of the crane should be at least twice the load imposed by the lifting of workers and their equipment. The lifting capacity of a forklift truck should be at least

five times the load imposed by the lifting of workers and their equipment, according to national law and practice.

3.1.3. While workers are on machinery designed for lifting loads, an operator should be in the control position at all times.

3.1.4. Persons being lifted should have reliable means of communication. In the event of danger, there should be a reliable means of evacuating them.

3.2. Mechanical strength

3.2.1. The carrier, including any trapdoors, should be designed and constructed in such a way as to offer the space and strength corresponding to the maximum number of persons permitted on the carrier and the maximum working load.

3.2.2. The working coefficients for components set out for lifting machinery are inadequate for machinery intended for the lifting of persons. Machinery intended for lifting either persons alone or persons and goods should be fitted with a suspension or supporting system for the carrier and be designed and constructed in such a way as to ensure an adequate overall level of safety and to prevent the risk of the carrier falling.

3.2.3. If ropes or chains are used to suspend the carrier, at least two independent ropes or chains are required, each with its own anchorage.

3.3. Loading control for machinery used for lifting persons and operated by power other than human effort

3.3.1. The requirements of loading control should apply unless the manufacturer can demonstrate that there is no risk of overloading or overturning, in accordance with national law and practice.

Safety and health in the use of machinery

3.4. Control devices

3.4.1. Where safety requirements do not impose other solutions, the carrier should as a general rule be designed and constructed in such a way that persons in the carrier have means of controlling upward and downward movements and any other movements of the carrier.

3.4.2. In operation, those control devices should override any other devices controlling the same movement, with the exception of emergency stop devices.

3.4.3. The control devices for these movements should be of the “hold-to-run” type unless the carrier itself is completely enclosed.

3.5. Risk to persons in or on the carrier

3.5.1. Risks due to movements of the carrier

3.5.1.1. Machinery for lifting persons should be designed, constructed or equipped in such a way that the acceleration or deceleration of the carrier does not create risks for persons.

3.5.2. Risk of persons falling from the carrier

3.5.2.1. The carrier should not tilt to an extent which creates a risk of the occupants falling, including when the machinery and carrier are moving.

3.5.2.2. Where the carrier is designed as a workstation, provision should be made to ensure stability and to prevent hazardous movements.

3.5.2.3. If the technical measures preventing a fall are not adequate, the carriers should be fitted with a sufficient number of suitable anchorage points for the number of persons permitted on the carrier. The anchorage points should be strong enough to permit the use of PPE against falls from a height.

3.5.2.4. Any trapdoor in floors or ceilings and any side doors should be designed and constructed in such a way as to prevent inadvertent opening, and should open in a direction that precludes any risk of falling should they open unexpectedly.

3.5.3. Risk due to objects falling on the carrier

3.5.3.1. Where there is a risk of objects falling on the carrier and endangering persons, the carrier should be equipped with a protective roof.

3.6. Machinery serving fixed landings (such as construction site hoists)

3.6.1. Risks to persons in or on the carrier

3.6.1.1. The carrier should be designed and constructed in such a way as to prevent risks due to contact between persons or objects and any fixed or moving parts, whether in or on the carrier. In order to fulfil this requirement, the carrier itself should, where necessary, be completely enclosed by doors fitted with an interlocking device that prevents hazardous movements of the carrier while the doors are open. The doors should remain closed if the carrier stops between landings, if there is a risk of falling from the carrier.

3.6.1.2. The machinery should be designed, constructed and, where necessary, equipped with devices in such a way as to prevent uncontrolled upward or downward movement of the carrier. These devices should be able to stop the carrier at its maximum working load and at the foreseeable maximum speed.

3.6.1.3. The stopping action should not cause deceleration that could be harmful to the occupants, whatever the load conditions.

Safety and health in the use of machinery

3.6.2. Controls on landings

3.6.2.1. Controls on landings, other than those used for emergencies, should not initiate movements of the carrier when:

- (a) the control devices in the carrier are being operated; or
- (b) the carrier is not at a landing.

3.6.3. Access to the carrier

3.6.3.1. The guards on the landings and on the carrier should be designed and constructed in such a way as to ensure safe transfer to and from the carrier, taking into consideration the foreseeable range of goods and persons to be lifted.

3.7. Markings

3.7.1. The carrier should bear the necessary information to ensure safety, including:

- (a) the number of persons permitted on the carrier; and
- (b) the maximum working load.

Appendix III

Example of a lathe as a prompt to assist in the risk assessment process for any machinery

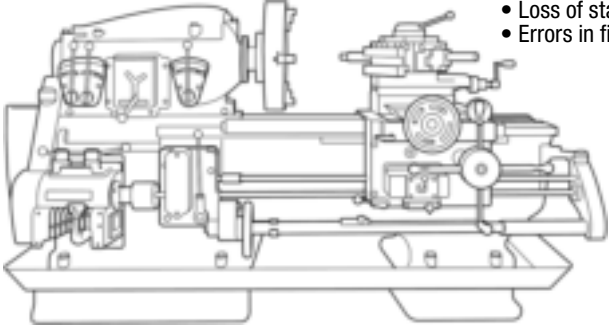
Materials/substances	Procedures	
<ul style="list-style-type: none">• Lubricating oils• Dust• Cleaning agents• Coolants• Fumes• Mists• Waste products	<ul style="list-style-type: none">• Use• Setting• Cleaning• Inspection• Servicing• Maintenance• Waste disposal• Loss of stability• Errors in fitting	
		
Equipment	Workplace	Workers
<ul style="list-style-type: none">• Lathe• Cutting tools• Accessories• Guarding/fencing/shield• Compressed air/pressurized liquids• Vibration• Energy sources• Noise• Radiation• Controls	<ul style="list-style-type: none">• Location• Services necessary to operate• Ventilation• Workspace/area• Lighting• Slip/trip/fall• Falling objects• Temperature	<ul style="list-style-type: none">• Operators• Setters• Cleaners• Maintenance• Service contractors

Appendix IV

Generic risk assessment template

Risk assessment template: Machinery				
Hazards	Yes/No	Likelihood	Severity	
Mechanical				
Electrical				
Thermal				
Noise				
Vibration				
Radiation				
Materials and substances				
Ergonomic				
Environmental				
Biological				
Unexpected start-up, overrun and overspeed				
Inadequate stopping				
Rotating parts				
Energy supply failure				
Control circuit failure				

Task	Date			
Risk = severity x likelihood	Actions to be taken	By whom	By when	

Safety and health in the use of machinery

Risk assessment template: Machinery				
Hazards	Yes/No	Likelihood	Severity	
Errors of fitting				
Break-up during operation				
Falling or ejected objects or fluids				
Loss of stability and overturning of machinery				
Slipping, tripping and falling				
Others				

Likelihood

- (1) Rare: has rarely if ever happened.
- (2) Unlikely: is possible, but is not expected to happen.
- (3) Possible: could be expected to happen once a year.
- (4) Likely: will probably occur, but is not persistent.
- (5) Almost certain: occurs regularly.

Severity

- (1) Insignificant: no injury or ill health.
- (2) Minor: short-term impact.
- (3) Moderate: semi-permanent injury or ill health.

Task		Date		
	Risk = severity x likelihood	Actions to be taken	By whom	By when

Appendix V

Ergonomic risk assessment template

Risk assessment template: Machinery				
Hazards/posture	Yes/No	Likelihood	Severity	
Ergonomic Operator's variability – Physical dimensions – Strength – Stamina Space for movements – Enough space for movements – Posture – Dynamic Work rate – Machine-determined work rate – Pace – Speed Concentration – Lengthy concentration – Vigilance – Mental operations				

Task		Date		
	Risk = severity x likelihood	Actions to be taken	By whom	By when

Safety and health in the use of machinery

Risk assessment template: Machinery				
Hazards/posture	Yes/No	Likelihood	Severity	
Human-machine interface – Adapted to the foreseeable characteristics of the operator – Visual – Auditory – Sensitivity – Sensory 1. Carrying of heavy loads 2. Stoop work or trunk bending 3. Non-neutral postures 4. Working in awkward postures 5. Working above shoulder height 6. Excessive forward reach 7. Fatigue from task frequency/ lack of breaks 8. Highly repetitive hand work 9. Excessive amount of hand-arm force 10. Vibration 11. Environmental exposures				

Task		Date		
	Risk = severity x likelihood	Actions to be taken	By whom	By when

Safety and health in the use of machinery

Machinery is used in virtually all work activities, and thus presents certain safety and health risks in a large number of workplaces all over the world. Many new types of machinery are also introduced into the market each year. This code of practice sets out principles concerning safety and health in the use of machinery and defines safety and health technical requirements and precautions, including those relating to the working environment, control systems, machinery guarding and protection against hazards, information and marking, and supplementary measures relating to specific machinery types. The code applies to any work activity in which machinery is used and to all stages of the life cycle of machinery, including second-hand, rebuilt or redeployed machinery used in workplaces.

ISBN 978-92-2-127725-5



9 789221 277255